

# ELECTRONICS MECHANIC

NSQF LEVEL - 4

2<sup>nd</sup> Year

---

## TRADE PRACTICAL

---

SECTOR: ELECTRONICS & HARDWARE

(As per revised syllabus July 2022 - 1200Hrs)



Directorate General of Training

DIRECTORATE GENERAL OF TRAINING  
MINISTRY OF SKILL DEVELOPMENT & ENTREPRENEURSHIP  
GOVERNMENT OF INDIA



**NATIONAL INSTRUCTIONAL  
MEDIA INSTITUTE, CHENNAI**

---

Post Box No. 3142, CTI Campus, Guindy, Chennai - 600 032

**Sector : Electronics & Hardware**

**Duration : 2 Years**

**Trade : Electronics Mechanic - 2<sup>nd</sup> Year Trade Practical - NSQF Level - 4 (Revised 2022)**

**Developed & Printed by**



**National Instructional Media Institute**

Post Box No.3142

Guindy, Chennai - 600032

INDIA

Email: [chennai-nimi@nic.in](mailto:chennai-nimi@nic.in)

Website: [www.nimi.gov.in](http://www.nimi.gov.in)

Copyright © 2023 National Instructional Media Institute, Chennai

First Edition : December 2023

Copies : 1000

**Rs. 320/-**

All rights reserved.

No part of this publication can be reproduced or transmitted in any form or by any means, electronic or mechanical, including photocopy, recording or any information storage and retrieval system, without permission in writing from the National Instructional Media Institute, Chennai.

## FOREWORD

The Government of India has set an ambitious target of imparting skills to 30 crores people, one out of every four Indians, to help them secure jobs as part of the National Skills Development Policy. Industrial Training Institutes (ITIs) play a vital role in this process especially in terms of providing skilled manpower. Keeping this in mind, and for providing the current industry relevant skill training to Trainees, ITI syllabus has been recently updated with the help of Media Development Committee members of various stakeholders viz. Industries, Entrepreneurs, Academicians and representatives from ITIs.

The National Instructional Media Institute (NIMI), Chennai, has now come up with instructional material to suit the revised curriculum for **Electronics Mechanic 2<sup>nd</sup> Year Trade Practical in Electronics & Hardware Sector** under **Yearly Pattern**. The NSQF Level - 4 (Revised 2022) Trade Practical will help the trainees to get an international equivalency standard where their skill proficiency and competency will be duly recognized across the globe and this will also increase the scope of recognition of prior learning. NSQF Level - 4 (Revised 2022) trainees will also get the opportunities to promote life long learning and skill development. I have no doubt that with NSQF Level - 4 (Revised 2022) the trainers and trainees of ITIs, and all stakeholders will derive maximum benefits from these Instructional Media Packages IMPs and that NIMI's effort will go a long way in improving the quality of Vocational training in the country.

The Director General, Executive Director & Staff of NIMI and members of Media Development Committee deserve appreciation for their contribution in bringing out this publication.

Jai Hind

**ATUL KUMAR TIWARI, I.A.S**

Secretary

Ministry of Skill Development & Entrepreneurship,  
Government of India.

December 2023  
New Delhi - 110 001

## PREFACE

The National Instructional Media Institute (NIMI) was established in 1986 at Chennai by then Directorate General of Employment and Training (D.G.E & T), Ministry of Labour and Employment, (now under Ministry of Skill Development and Entrepreneurship) Government of India, with technical assistance from the Govt. of the Federal Republic of Germany. The prime objective of this institute is to develop and provide instructional materials for various trades as per the prescribed syllabi under the Craftsman and Apprenticeship Training Schemes.

The instructional materials are created keeping in mind, the main objective of Vocational Training under NCVT/NAC in India, which is to help an individual to master skills to do a job. The instructional materials are generated in the form of Instructional Media Packages (IMPs). An IMP consists of Theory book, Practical book, Test and Assignment book, Instructor Guide, Audio Visual Aid (Wall charts and Transparencies) and other support materials.

The trade practical book consists of series of exercises to be completed by the trainees in the workshop. These exercises are designed to ensure that all the skills in the prescribed syllabus are covered. The trade theory book provides related theoretical knowledge required to enable the trainee to do a job. The test and assignments will enable the instructor to give assignments for the evaluation of the performance of a trainee. The wall charts and transparencies are unique, as they not only help the instructor to effectively present a topic but also help him to assess the trainee's understanding. The instructor guide enables the instructor to plan his schedule of instruction, plan the raw material requirements, day to day lessons and demonstrations.

In order to perform the skills in a productive manner instructional videos are embedded in QR code of the exercise in this instructional material so as to integrate the skill learning with the procedural practical steps given in the exercise. The instructional videos will improve the quality of standard on practical training and will motivate the trainees to focus and perform the skill seamlessly.

IMPs also deals with the complex skills required to be developed for effective team work. Necessary care has also been taken to include important skill areas of allied trades as prescribed in the syllabus.

The availability of a complete Instructional Media Package in an institute helps both the trainer and management to impart effective training.

The IMPs are the outcome of collective efforts of the staff members of NIMI and the members of the Media Development Committees specially drawn from Public and Private sector industries, various training institutes under the Directorate General of Training (DGT), Government and Private ITIs.

NIMI would like to take this opportunity to convey sincere thanks to the Directors of Employment & Training of various State Governments, Training Departments of Industries both in the Public and Private sectors, Officers of DGT and DGT field institutes, proof readers, individual media developers and coordinators, but for whose active support NIMI would not have been able to bring out this materials.

**Chennai - 600 032**

**EXECUTIVE DIRECTOR**

## ACKNOWLEDGEMENT

National Instructional Media Institute (NIMI) sincerely acknowledges with thanks for the co-operation and contribution extended by the following Media Developers and their sponsoring organisations to bring out this Instructional Material (**Trade Practical**) for the trade of **Electronics Mechanic 2<sup>nd</sup> Year NSQF Level - 4 (Revised 2022)** under **Electronics & Hardware** Sector for ITIs.

### MEDIA DEVELOPMENT COMMITTEE MEMBERS

Smt. S. Gowri	-	Assistant Training Officer, Govt. ITI, Thiruvanmiyur.
Smt. P.R. Nancy	-	Junior Training Officer, Govt. ITI, Guindy.
Shri. A. Sunderesan	-	Junior Training Officer, Govt. ITI, Hosur.

### NIMICO-ORDINATORS

Shri. Nirmalya nath	-	Deputy Director of Training, NIMI, Chennai - 32.
Shri. S. Gopalakrishnan	-	Assistant Manager, NIMI, Chennai - 32.

NIMI records its appreciation of the Data Entry, CAD, DTP Operators for their excellent and devoted services in the process of development of this Instructional Material.

NIMI also acknowledges with thanks, the invaluable efforts rendered by all other staff who have contributed for the development of this Instructional Material.

NIMI is grateful to all others who have directly or indirectly helped in developing this IMP.

# INTRODUCTION

## TRADE PRACTICAL

The trade practical manual is intended to be used in practical workshop. It consists of a series of practical exercises to be completed by the trainees during the course. These exercises are designed to ensure that all the skills in compliance with NSQF Level - 4 (Revised 2022) syllabus are covered.

The manual is divided into Sixteen modules

Module 1	<b>Electronic Cables and Connectors</b>
Module 2	<b>Computer Hardware, OS, MS Office and Networking</b>
Module 3	<b>Basic SMD (2,3,4 terminal components), soldering and desoldering</b>
Module 4	<b>PCB Rework</b>
Module 5	<b>Protection Devices and Electrical Control Circuits</b>
Module 6	<b>Communication Electronics</b>
Module 7	<b>Microcontroller (8051)</b>
Module 8	<b>Sensors, Transducers and applications</b>
Module 9	<b>IoT Applications</b>
Module 10	<b>Fiber Optic communication</b>
Module 11	<b>Digital Panel Meter</b>
Module 12	<b>SMPS and Inverter, UPS</b>
Module 13	<b>Solar power (Renewable energy system)</b>
Module 14	<b>Cell phones</b>
Module 15	<b>LED Lights</b>
Module 16	<b>LCD &amp; LED TV</b>

The skill training in the shop floor is planned through a series of practical exercises centered around some practical project. However, there are few instances where the individual exercise does not form a part of project.

While developing the practical manual, a sincere effort was made to prepare each exercise which will be easy to understand and carry out even by below average trainee. However the development team accept that there is a scope for further improvement. NIMI looks forward to the suggestions from the experienced training faculty for improving the manual.

## TRADE THEORY

The manual of trade theory consists of theoretical information for the Course of the **Electronics Mechanic 2<sup>nd</sup> Year NSQF Level - 4 (Revised 2022) in Electronics & Hardware**. The contents are sequenced according to the practical exercise contained in NSQF Level - 4 (Revised 2022) syllabus on Trade Theory attempt has been made to relate the theoretical aspects with the skill covered in each exercise to the extent possible. This correlation is maintained to help the trainees to develop the perceptual capabilities for performing the skills.

The trade theory has to be taught and learnt along with the corresponding exercise contained in the manual on trade practical. The indications about the corresponding practical exercises are given in every sheet of this manual.

It will be preferable to teach/learn trade theory connected to each exercise at least one class before performing the related skills in the shop floor. The trade theory is to be treated as an integrated part of each exercise.

The material is not for the purpose of self-learning and should be considered as supplementary to class room instruction.

## CONTENTS

Ex.No.	Title of Exercise	Learning Outcome	Page No.
<b>Module 1 : Electronic Cables and Connectors</b>			
2.1.135	Identify various types of cables used for Audio, Video and RF signal with different input output socket	1	1
2.1.136	Identify suitable connectors, solder / crimp/ terminate and test the cable sets		3
2.1.137	Check the continuity as per the marking on the connector for preparing the cable set		5
2.1.138	Identify and select various connectors and cables inside the CPU cabinet of PC		7
2.1.139	Identify the suitable connector and cable to connect computer with a network switch and Prepare the crossover cable to connect two network computer		9
<b>Module 2 : Computer Hardware, OS,MS Office and Networking</b>			
2.2.140	Demonstrate various parts of the system unit and motherboard components	2	13
2.2.141	Identify various computer peripherals and connect it to the system		14
2.2.142	Disable certain functionality by disconnecting the concerned cables SATA / PATA		16
2.2.143	Replace the CMOS battery and extend a memory module		17
2.2.144	Test and replace the SMPS		19
2.2.145	Replace the given DVD and HDD on the system		20
2.2.146	Dismantle and assemble the desktop computer system		22
2.2.147	Boot the system from different options		26
2.2.148	Install OS in a desktop computer		28
2.2.149	Install a printer driver software and test for printouts		30
2.2.150	Install antivirus software, scan the system and explore the options in the antivirus software		33
2.2.151	Install MS Office software		35
2.2.152	Browse search engines, create email accounts, practice sending and receiving of mails and configuration of email clients		37
2.2.153	Prepare terminations, make UTP and STP cable connectors and test		42
2.2.154	Configure a wireless Wi-Fi network		45
<b>Module 3 : Basic SMD (2,3,4 terminal components), soldering and desoldering</b>			
2.3.155	Identification of 2,3,4 terminal SMD components	3	47
2.3.156	Desolder the SMD Components from the given PCB		51
2.3.157	Solder the SMD components in the same PCB		53
2.3.158	Check for cold continuity of PCB		54
2.3.159	Identification of loose / dry solder / broken tracks on printed wired assemblies		55
2.3.160	Identify various connections and setup required for SMD soldering station		57
2.3.161	Identify crimping tools for various IC packages		59
2.3.162	Make the necessary settings on the SMD soldering workstation to desolder various ICs of different packages		60
2.3.163	Make necessary settings on SMD soldering station to solder various ICs of different Packages		62
2.3.164	Setting for rework of defective Surface Mount Components using soldering/ desoldering method		65

Ex.No.	Title of Exercise	Learning Outcome	Page No.
	<b>Module 4 : PCB Rework</b>		
2.4.165	Check and repair PCBs single, double layer and important test for PCBs	4	68
2.4.166	Inspect soldered joints, detect the defects and test the PCB for rework		70
	<b>Module 5 : Protection Devices and Electrical Control Circuits</b>		
2.5.167A	Identify different types of fuses along with fuse holders, over load relay, (no volt coil) current adjust bimetallic strips to set the current		74
2.5.167B	Test the given MCBs		76
2.5.168	Connect an ELCB and test the leakage of an electrical motor control circuit	5	78
2.5.169	Test DC motor and its operating voltage		80
2.5.170	Test DC motor control signal		81
2.5.171	Test various low potential motors		82
2.5.172	Test stepper motors		83
2.5.173	Demonstrate working process of stepper motor in various equipments		84
	<b>Module 6 : Communication Electronics</b>		
2.6.174	Modulate and demodulate various signals using AM and FM on the trainer kit and observe waveforms		85
2.6.175	Test IC based AM receiver		87
2.6.176	Test IC based FM transmitter		88
2.6.177	Test IC based AM transmitter and test the transmitter power. Calculate the modulation index	6	89
2.6.178	Dismantle the given FM receiver set and identify different stages (AM section, audio amplifier section etc)		91
2.6.179	Modulate two signals using AM kit, draw the waveform and calculate the percentage (%) of modulation		93
2.6.180	Modulate and demodulate signal using PAM, PPM, PWM techniques		95
	<b>Module 7 : Microcontroller (8051)</b>		
2.7.181	Identify various ICs and their function on the given microcontroller kit		99
2.7.182	Identify the address range of RAM & ROM of 8051 microcontroller		100
2.7.183	Measure the crystal frequency, connect it to the controller		101
2.7.184	Identify the port pins of the microcontroller and configure the ports for Input /Output operation	7	102
2.7.185	Use 8051 microcontroller, connect 8 LEDs to the port and blink the LEDs with switch		103
2.7.186	Perform the initialization, load and turn ON a LED with delay using timer		104
2.7.187	Perform the use of timer as an event counter to count external events		105
2.7.188	Demonstrate entering of simple programs, execute and monitor the result		106
	<b>Module 8 : Sensors, Transducers and applications</b>		
2.8.189	Identification of different sensors used in process industries such as RTD, Temperature, ICs, Thermocouples, proximity switches (inductive capacitive photo electric) Load cells		108
2.8.190	Measure temperature of a lit fire using a Thermocouple and record the readings referring to data chart	8	109
2.8.191	Measure temperature of a lit fire using RTD and record the readings referring to data		112
2.8.192	Measure the DC voltage of a LVDT		114



Ex.No.	Title of Exercise	Learning Outcome	Page No.
2.8.193	Detect different objectives using capacitive, inductive and photoelectric proximity sensors		116
	<b>Module 9 : IoT Applications</b>		
2.9.194	Connect and test microcontroller to computer and execute sample programs		119
2.9.195	Upload computer code to the physical board (microcontroller) to blink a simple LED		122
2.9.196	Write and upload computer code to the physical Micro controller to sound buzzer	9	124
2.9.197	Circuit and program to Interface light sensor – LDR with Microcontroller to switch ON/OFF LED based on light intensity		125
2.9.198	Set up & test circuit to interface potentiometer with microcontroller and map to digital values for e.g. 0-1023		126
	<b>Module 10 : Fiber Optic communication</b>		
2.10.199	Identify the resources and their need on the given fiber optic trainer kit		128
2.10.200	Make optical fiber set up to transmit and receive analog and digital data		130
2.10.201	Set up the OFC trainer kit to study AM, FM, PWM modulation and demodulation		133
2.10.202	Perform FM modulation and demodulation using OFC trainer kit using audio signal and voice link	10	137
2.10.203	Perform PWM modulation and demodulation using OFC trainer kit using audio signal and voice link		139
2.10.204	Perform PPM modulation and demodulation using fiber optic communication trainer kit using audio signal and voice link		141
	<b>Module 11 : Digital Panel Meter</b>		
2.11.205	Identify LED display module and its decoder/driver ICs		143
2.11.206	Construction of a two line LED		145
2.11.207	Measure current flowing through a resistor and display it on LED module	11	147
2.11.208	Measure current flowing through sensor and display it on LED Module		148
2.11.209	Identify LCD display module and its decoder/driver ICs		150
2.11.210	Measure current flowing through a resistor and display it		152
	<b>Module 12 : SMPS and Inverter, UPS</b>		
2.12.211	Identify the components/devices of SMPS and draw their corresponding symbols		153
2.12.212	Dismantle the given voltage stabilizer and find the major sections/ICs /Components		156
2.12.213	List the defect and symptom in the faulty SMPS		157
2.12.214	Measure/ Monitor at major test points of computer SMPS unit		160
2.12.215	Troubleshoot the fault in the given SMPS unit, rectify the defect and verify the output with load (Record your procedure followed for troubleshooting the defects)		165
2.12.216	Use SMPS used in TVs and PCs for practice	12	171
2.12.217	Install and test the SMPS in PC		174
2.12.218	Install and test an inverter		175
2.12.219	Troubleshoot the fault in the given inverter unit, rectify the defects and verify the output with load		177
2.12.220	Construct and test IC based DC to DC converter for different voltages		179
2.12.221	Construct and test a switching step down regulator using LM 2576		182
2.12.222	Construct and test a switching step up regulator using MC34063		183

Ex.No.	Title of Exercise	Learning Outcome	Page No.
2.12.223	Connect battery stack to the UPS		184
2.12.224	Identify front panel controls & indicators of UPS		185
2.12.225	Connect battery & load to UPS & test on battery mode		187
2.12.226	Open top cover of a UPS; identify its isolation transformers, the UPS transformer and various circuit boards in UPS		190
2.12.227	Identify the various test points and verify the voltages on the UPS		192
2.12.228	Identify various circuit boards in UPS and monitor voltages at various test points		193
2.12.229	Perform load test to measure backup time		195
<b>Module 13 : Solar power (Renewable energy system)</b>			
2.13.230A	Identify and test an LED and a Photodiode to verify the photo emitting effect and light sensitivity		197
2.13.230B	Test a Photo voltaic cell for different illumination levels and verify photovoltaic property		199
2.13.230C	Plot I-V curve for photovoltaic cell based on the illumination at constant temperature		201
2.13.230D	Plot I-V curve for photovoltaic cell based on temperature at constant illumination		204
2.13.230E	Test photovoltaic cell in sunlight at various angles of inclination and direction	13	206
2.13.230F	Wire a solar controller to a battery storage station		208
2.13.231	Connect storage batteries to a power inverter		209
2.13.232	Connect and test solar panel to the inverter and run the load		211
2.13.233	Install a solar power to charge a rechargeable 12V DC battery and find out the charging time		214
2.13.234	Install a solar inverter		215
<b>Module 14 : Cell phones</b>			
2.14.235	Dismantle, Identify the parts and assemble different types of smart phones		217
2.14.236	Dismantle the cell phone / smart phone remove the keypad and clean it , test the continuity of the matrix/tracks		222
2.14.237	Interface the cell phone/smart phone to PC and transfer the data card		224
2.14.238	Flash the various brands of cell phones/smart phones		227
2.14.239	Format the cell phone/smart phone for virus(approach the mobile repair shop, service center)	14	228
2.14.240	Perform the interfacing of Cell phone/Smart phone to the PC and dismantle the cell phone and identify the power section and test its healthiness		230
2.14.241	Find out the fault of basic cell phone system. Rectify the fault in ringer section and check the performance		233
2.14.242	Replace various faulty parts like mic, speaker, charging/audio jack etc		234
<b>Module 15 : LED Lights</b>			
2.15.243	Dismantle the LED light, identify the connections of LED stacks, protection circuit and regulator		236
2.15.244	Identify the rectifier, controller part of LED lights		238
2.15.245	Make series strings connection of six LEDs and connect four series strings in parallel	15	210
2.15.246	Connect to such parallel sets in series to create a matrix of LEDs		242
2.15.247	Apply suitable voltage and check voltage across series strings		243
<b>Module 16 : LCD &amp; LED TV</b>			
2.16.248	Identify and operate different controls on LCD, LED TV		244
2.16.249	Identify components and different sections of LCD and LED TV		246

Ex.No.	Title of Exercise	Learning Outcome	Page No.
2.16.250	Dismantle, identify the parts of TV remote control	16	248
2.16.251	Dismantle the given LCD/LED TV to find faults with input stages through connectors		250
2.16.252	Detect the defect in a LED/LCD TV receiver given to you. Rectify the fault		252
2.16.253	Troubleshoot the faults in the given LED/LCD TV receiver - Locate and rectify the faults		254
2.16.254	Test LED/LCD TV after troubleshooting the defects		256
2.16.255	Identify various connectors and connect the cable operators external decoder (Set-top box) to the TV		259

## LEARNING / ASSESSABLE OUTCOME

On completion of this book you shall be able to

S.No	Learning Outcome	Ref. Ex.No.
1	Prepare, crimp, terminate and test various cables used in different electronics industries. <b>(Mapped NOS: ELE/N6307)</b>	2.1.135 - 139
2	Install, configure, interconnect given computer system(s) and demonstrate & utilize application packages for different application. <b>(Mapped NOS: ELE/N4614)</b>	2.2.140 - 154
3	Identify, place, solder and desolder and test different SMD discrete components and ICs package with due care and following safety norms using proper tools/ setup. <b>(Mapped NOS: ELE/N5102)</b>	2.3.155 - 164
4	Rework on PCB after identifying defects from SMD soldering and desoldering. <b>(Mapped NOS: ELE/N5102)</b>	2.4.165 - 166
5	Construct different electrical control circuits and test for their proper functioning with due care and safety. <b>(Mapped NOS: ELE/N9407)</b>	2.5.167 - 173
6	Assemble and test a commercial AM/ FM receiver and evaluate performance. <b>(Mapped NOS: ELE/N9408)</b>	2.6.174 - 180
7	Test, service and troubleshoot the various components of different domestic/ industrial programmable systems. <b>(Mapped NOS: ELE/N9802)</b>	2.7.181 - 188
8	Execute the operation of different sensors, identify, wire & test various transducers of IOT Applications <b>(Mapped NOS: ELE/N9409)</b>	2.8.189 - 193
9	Identify different IoT Applications with IoT architecture. <b>(Mapped NOS: ELE/N3102)</b>	2.9.194 - 198
10	Plan and carry out the selection of a project, assemble the project and evaluate performance for a domestic/ commercial applications. <b>(Mapped NOS: ELE/N9802)</b>	
10	Prepare fibre optic setup and execute transmission and reception. <b>(Mapped NOS: ELE/N5902)</b>	2.10.199-204
11	Plan and Interface the LCD, LED, DPM panels to various circuits and evaluate performance. <b>(Mapped NOS: ELE/N8107)</b>	2.11.205-210
12	Detect the faults and troubleshoot SMPS, UPS and inverter. <b>(Mapped NOS: ELE/N7202)</b>	2.12.211 - 229
13	Identify, Test and verify characteristics of Photovoltaic cells, Modules, Batteries and Charge controllers. Install a solar panel, execute testing and evaluate performance by connecting the panel to the inverter. <b>(Mapped NOS: ELE/N5902)</b>	2.13.230A - 234
14	Dismantle, identify the various parts and interface of a cell phone to a PC. Estimate and trouble shoot. <b>(Mapped NOS: ELE/N8107)</b>	2.14.235 - 242
15	Check the various parts of a LED lights & stacks and troubleshoot. <b>(Mapped NOS: ELE/N9302)</b>	2.15.243 - 247
16	Identify, operate various controls, troubleshoot and replace modules of the LCD/LED TV & its remote. <b>(Mapped NOS: ELE/N3102)</b>	2.16.248 - 255

## SYLLABUS FOR ELECTRONICS MECHANIC

Duration	Reference Learning Outcome	Professional Skill (Trade Practical) (With indicative hour)	Professional Knowledge (Trade Theory)
Professional Skill 25 Hrs; Professional Knowledge 06 Hrs	Prepare, crimp, terminate and test various cables used in different electronics industries. <b>(Mapped NOS: ELE/N6307)</b>	<p><b>Electronic Cables &amp; Connectors</b></p> <p>135. Identify various types of cables viz. RF coaxial feeder, screened cable, ribbon cable, RCA connector cable, digital optical audio, video cable, RJ45, RJ11, Ethernet cable, fibre optic cable splicing, fibre optic cable mechanical splices, insulation, gauge, current capacity, flexibility etc. used in various electronics products, different input output sockets. (05 Hrs.)</p> <p>136. Identify suitable connectors, solder/crimp /terminate &amp; test the cable sets. (05 Hrs.)</p> <p>137. Check the continuity as per the marking on the connector for preparing the cable set. (05 Hrs.)</p> <p>138. Identify and select various connectors and cables inside the CPU cabinet of PC. (05 Hrs.)</p> <p>139. Identify the suitable connector and cable to connect a computer with a network switch and prepare a cross over cable to connect two network computers. (05 Hrs.)</p>	Cable signal diagram conventions Classification of electronic cables as per the application w.r.t. insulation, gauge, current capacity, flexibility etc. Different types of connector & their terminations to the cables. Male / Female type DB connectors. Ethernet 10 Base cross over cables and pin out assignments, UTP and STP, SCTP, TPC, coaxial, types of fibre optical Cables and Cable trays. Different types of connectors Servo 0.1" connectors, FTP, RCA, BNC, HDMI Audio/video connectors like XLR, RCA (phono), 6.3 mm PHONO, 3.5 / 2.5 mm PHONO, BANTAM, SPEAKON, DIN, mini DIN, RF connectors, USB, Fire wire, SATA Connectors, VGA, DVI connectors, MIDI and RJ45, RJ11 etc. (06 Hrs.)
Professional Skill 80 Hrs; Professional Knowledge 34 Hrs	Install, configure, interconnect given computer Install, onfigure,interconnect given computer system(s) and demonstrate & utilize application packages for different application. <b>(Mapped NOS: ELE/N4614)</b>	<p><b>Computer Hardware, OS, MS office and Networking</b></p> <p>140. Demonstrate various parts of the system unit and motherboard components. (06 Hrs.)</p> <p>141. Identify various computer peripherals and connect it to the system. (04Hrs.)</p> <p>142. Disable certain functionality by disconnecting the concerned cables SATA/ PATA. (05 Hrs.)</p> <p>143. Replace the CMOS battery and extend a memory module. (06 Hrs.)</p> <p>144. Test and Replace the SMPS. (05 Hrs.)</p> <p>145. Replace the given DVD and HDD on the system. (06 Hrs.)</p> <p>146. Dismantle and assemble the desktop computer system. (07 Hrs.)</p> <p>147. Boot the system from Different options. (07 Hrs.)</p>	Basic blocks of a computer, Components of desktop and motherboard.  Hardware and software, I/O devices, and their working. Different types of printers, HDD, DVD. Various ports in the computer. Windows OS MS widows: Starting windows and its operation, file management using explorer, Display & sound properties, screen savers, fontmanagement, installation of program, setting and using of control panel, application of accessories, various IT tools and applications. Concept of Internet, Browsers, Websites, search engines, email, chatting and messenger service. Downloading the Data and program files etc.

		<p>148. Install OS in a desktop computer. (05 Hrs.)</p> <p>149. Install a Printer driver software and test for print outs. (05 Hrs.)</p> <p>150. Install antivirus software, scan the system and explore the options in the antivirus software. (05 Hrs.)</p> <p>151. Install MS office software. (05 Hrs.)</p> <p>152. Browse search engines, create email accounts, practice sending and receiving of mails and configuration of email clients. (08 Hrs.)</p> <p>153. Prepare terminations, make UTP and STP cable connectors and test. (08 Hrs.)</p> <p>154. Configure a wireless Wi-Fi network. (10 Hrs.)</p>	<p><b>Computer Networking:-</b></p> <p>Network features - Network medias Network topologies, protocols- TCP/ IP, UDP, FTP, models and types. Specification and standards, types of cables, UTP, STP, Coaxial cables. Network components like hub, Ethernet switch, router, NIC Cards, connectors, media and firewall. Difference between PC &amp; Server. (34 Hrs.)</p>
Professional Skill 70 Hrs; Professional Knowledge 20 Hrs	Identify, place, solder and desolder and test different SMD discrete components and ICs package with due care and following safety norms using proper tools/setup. <b>(Mapped NOS: ELE/N5102)</b>	<p><b>Basic SMD (2, 3, 4 terminal components)</b></p> <p>155. Identification of 2, 3, 4 terminal SMD components. (05 Hrs.)</p> <p>156. De-solder the SMD components from the given PCB. (05 Hrs.)</p> <p>157. Solder the SMD components in the same PCB. (05 Hrs.)</p> <p>158. Check for cold continuity of PCB. (05 Hrs.)</p> <p>159. Identification of loose /dry solder, broken tracks on printed wired assemblies. (05 Hrs.)</p>	Introduction to SMD technology Identification of 2, 3, 4 terminal SMD components. Advantages of SMD components over conventional lead components. Soldering of SM assemblies - Reflow soldering. Tips for selection of hardware, Inspection of SM. (05 Hrs.)
		<p><b>SMD Soldering and Desoldering</b></p> <p>160. Identify various connections and setup required for SMD Soldering station. (05 Hrs.)</p> <p>161. Identify crimping tools for various IC packages. (05 Hrs.)</p> <p>162. Make the necessary settings on SMD soldering station to de-solder various ICs of different packages (at least four) by choosing proper crimping tools. (07 Hrs.)</p> <p>163. Make the necessary settings on SMD soldering station to solder various ICs of different packages (at least four) by choosing proper crimping tools. (8 Hrs.)</p> <p>164. Make the necessary setting rework of defective surface mount component used soldering / de-soldering method. (8 Hrs.)</p>	<p>Introduction to Surface Mount Technology (SMT). Advantages, Surface Mount components and packages. Introduction to solder paste (flux).</p> <p>Soldering of SM assemblies, reflow soldering. Tips for selection of hardware, Inspection of SM. Identification of Programmable Gate array (PGA) packages. Specification of various tracks, calculation of track width for different current ratings. Cold/ Continuity check of PCBs. Identification of lose / dry solders, broken tracks on printed wiring assemblies. Introduction to Pick place Machine, Reflow Oven, Preparing stencil, &amp; stencil printer (15 Hrs.)</p>

Professional Skill 20 Hrs; Professional Knowledge 10 Hrs	Rework on PCB after identifying defects from SMD soldering and desoldering. <b>(Mapped NOS: ELE/N5102)</b>	<b>PCB Rework</b> 165. Checked and Repair Printed Circuit Boards single, Double layer and important tests for PCBs. (10 Hrs.) 166. Inspect soldered joints, detect the defects and test the PCB for rework. (10Hrs.)	Introduction to Static charges, prevention, handling of static sensitive devices, various standards for ESD. Introduction to non-soldering interconnections. Construction of Printed Circuit Boards (single, Double, multilayer), Important tests for PCBs. Introduction to rework and repair concepts. Repair of damaged track. Repair of damaged pad and plated through hole. Repair of solder mask. (10 Hrs.)
Professional Skill 30 Hrs; Professional Knowledge 10 Hrs	Construct different electrical control circuits and test for their proper functioning with due care and safety. <b>(Mapped NOS: ELE/N9407)</b>	<b>Protection devices</b> Identify different types of fuses along with fuse holders, overload (no volt coil), current adjust (Biometric strips to set the current). (06 Hrs.) 167. Test the given MCBs. (03 Hrs.) 168. Connect an ELCB and test the leakage of an electrical motor control circuit. (05 Hrs.) 169. Test DC motor and its operating voltage. (03 Hrs.) 170. Test DC motor control signal. (03 Hrs.) 171. Test various Low potential motors. (03 Hrs.) <b>Stepper Motor</b> 172. Test stepper motor. (03 Hrs.) 173. Demonstrate working process of stepper motor in various Equipment. (04 Hrs.)	Necessity of fuse, fuse ratings, types of fuses, fuse bases. Single/ three phase MCBs, single phase ELCBs. Types of contactors, relays and working voltages. Contact currents, protection to contactors and high current applications. (05 Hrs.)  <b>1.LOW VOLTAGE DC MOTOR</b> (Low Potential motor) Introduction of DC motor. Types of DC motor .Types of DC motor controller. DC Motor power. Types of DC Motor power regulation. Application area of DC motor controller. 2.What is a Stepper motor and its types. Stepper Motor working Principal. How to select a stepper motor Types of wiring of stepper motor. Stepper motor control by varying clock pulses. Advantage of stepper motor. (05 Hrs.)
Professional Skill 60 Hrs; Professional Knowledge 15 Hrs	Assemble and test a commercial AM/ FM receiver and evaluate performance. <b>(Mapped NOS: ELE/N9408)</b>	<b>Communication electronics</b> 174. Modulate and Demodulate various signals using AM and FM on the trainer kit and observe waveforms. (08 Hrs.) 175. Test IC based AM Receiver (08 Hrs.) 176. Test IC based FM transmitter. (06 Hrs.) 177. Test IC based AM transmitter and test the transmitter power Calculate the modulation index. (08 Hrs.) 178. Dismantle the given FM receiver set and identify different stages (AM section, audio amplifier section etc). (10 Hrs.)	Radio Wave Propagation – principle, fading. Need for Modulation, types of modulation and demodulation. Fundamentals of Antenna, various parameters, types of Antennas & application. Introduction to AM, FM & PM, SSB-SC & DSB-SC. Block diagram of AM and FM transmitter. FM Generation & Detection. Digital modulation and demodulation techniques, sampling, quantization & encoding. Concept of multiplexing and de multiplexing of AM/ FM/ PAM/ PPM /PWM signals. A simple block diagram approach to be adopted for explaining the above mod/demod techniques. (15 Hrs.)

		<p>179. Modulate two signals using AM kit draw the way from and calculate percent (%) of modulation. (10 Hrs.)</p> <p>180. Modulate and Demodulate a signal using PAM, PPM, PWM Techniques. (10 Hrs.)</p>	
<p>Professional Skill 60 Hrs; Professional Knowledge 15 Hrs</p>	<p>Test, service and troubleshoot the various components of different domestic/ industrial programmable systems. <b>(Mapped NOS: ELE/N9802)</b></p>	<p><b>Microcontroller (8051)</b></p> <p>181. Identify various ICs &amp; their functions on the given Microcontroller Kit. (07 Hrs.)</p> <p>182. Identify the address range of RAM &amp; ROM. (07 Hrs.)</p> <p>183. Measure the crystal frequency, connect it to the controller. (07 Hrs.)</p> <p>184. Identify the port pins of the controller &amp; configure the ports for Input &amp; Output operation. (07 Hrs.)</p> <p>185. Use 8051 microcontroller, connect 8 LED to the port, blink the LED with a switch. (08 Hrs.)</p> <p>186. Perform the initialization, load &amp; turn on a LED with delay using Timer. (08 Hrs.)</p> <p>187. Perform the use of a Timer as an Event counter to count external events. (08 Hrs.)</p> <p>188. Demonstrate entering of simple programs, execute &amp; monitor the results. (08 Hrs.)</p>	<p>Introduction Microprocessor &amp; 8051 Microcontroller, architecture, pin details &amp; the bus system. Function of different ICs used in the Microcontroller Kit. Differentiate microcontroller with microprocessor. Interfacing of memory to the microcontroller. Internal hardware resources of microcontroller. I/O port pin configuration. Different variants of 8051 &amp; their resources. Register banks &amp; their functioning. SFRs &amp; their configuration for different applications. Comparative study of 8051 with 8052. Introduction to PIC Architecture (15 Hrs.)</p>
<p>Professional Skill 60 Hrs; Professional Knowledge 15 Hrs</p>	<p>Execute the operation of different sensors, identify, wire &amp; test various transducers of IOT Applications <b>(Mapped NOS: ELE/N9409)</b></p>	<p><b>Sensors, Transducers used in IoT Applications</b></p> <p>189. Identify sensors used in process industries such as RTDs, temperature ICs, Thermocouples, proximity switches (inductive, capacitive and photo electric), load cells, strain gauge. LVDT PT 100 (platinum resistance sensor), water level sensor, thermostat float switch, float valve by their appearance. (15 Hrs.)</p> <p>190. Measure temperature of a lit fire using a Thermocouple and record the readings referring to data chart. (10 Hrs.)</p> <p>191. Measure temperature of a lit fire using RTD and record the readings referring to data. (10 Hrs.)</p> <p>192. Measure the DC voltage of a LVDT. (10 Hrs.)</p> <p>193. Detect different objectives using capacitive, inductive and photoelectric proximity sensors. (15 Hrs.)</p>	<p>Basics of passive and active transducers. Role, selection and characteristics. Sensor voltage and current formats. Thermistors/ Thermocouples - Basic principle, salient features, operating range, composition, advantages and disadvantages. Strain gauges/ Load cell – principle, gauge factor, types of strain gauges. Inductive/ capacitive transducers - Principle of operation, advantages and disadvantages.</p> <p>Principle of operation of LVDT, advantages and disadvantages. Proximity sensors – applications, working principles of eddy current, capacitive and inductive proximity sensors. (15 Hrs.)</p>

Professional Skill 20 Hrs.; Professional Knowledge 06 Hrs.	Identify different IoT Applications with IoT architecture. <b>(Mapped NOS: ELE/N3102)</b>	194. Connect and test microcontroller to computer and execute sample programs. (04hrs.) 195. Upload computer code to the physical board (Microcontroller) to blink a simple LED. (02hrs.) 196. Write and upload computer code to the physical Micro controller to sound buzzer. (02hrs.) 197. Circuit and program to Interface light sensor – LDR with Microcontroller to switch ON/OFF LED based on light intensity. (03hrs.) 198. Set up & test circuit to interface potentiometer with Microcontroller and map to digital values for e.g. 0-1023. (03hrs.)	Introduction to Internet of Things applications environment, smart street light and smart water & waste management. What is an IOT? What makes embedded system an IOT? Role and scope of IOT in present and future marketplace. Smart objects, Wired – Cables, hubs etc. Wireless – RFID, WiFi, Bluetooth etc. Different functional building blocks of IOT architecture. (06 hrs.)
Professional Skill 90 Hrs; Professional Knowledge 18 Hrs	Plan and carry out the selection of a project, assemble the project and evaluate performance for a domestic/commercial applications. <b>(Mapped NOS: ELE/N9802)</b>	<b>Analog IC Applications</b> Make simple projects/ Applications using ICs 741, 723, 555, 7106, 7107 <b>Sample projects:</b> <ul style="list-style-type: none"> <li>• Laptop protector</li> <li>• Mobile cell phone charger</li> <li>• Battery monitor</li> <li>• Metal detector</li> <li>• Mains detector</li> <li>• Lead acid battery charger</li> <li>• Smoke detector</li> <li>• Solar charger</li> <li>• Emergency light</li> <li>• Water level controller</li> <li>• Door watcher</li> </ul> (Instructor will pick up any five of the projects for implementation) (45 Hrs.)	Discussion on the identified projects with respect to data of the concerned ICs. Components used in the project. (09 Hrs.)
		<b>Digital IC Applications</b> Make simple projects/Applications using various digital ICs (digital display, event counter, stepper motor driver etc) <ul style="list-style-type: none"> <li>• Duty cycle selector</li> <li>• Frequency Multiplier</li> <li>• Digital Mains Resumption Alarm</li> <li>• Digital Lucky Random number generator</li> <li>• Dancing LEDs</li> </ul>	Discussion on the identified projects with respect to data of the concerned ICs. Components used in the project. (09 Hrs.)



		<ul style="list-style-type: none"> <li>• Count down timer</li> <li>• Clap switch</li> <li>• Stepper motor control</li> <li>• Digital clock</li> <li>• Event counter</li> <li>• Remote jammer</li> </ul> (Instructor will pick up any five of the projects for implementation) (45 Hrs.)	
Professional Skill 15 Hrs; Professional Knowledge 05 Hrs	Prepare fibre optic setup and execute transmission and reception. <b>(Mapped NOS: ELE/N5902)</b>	<b>Fiber optic communication</b> 199. Identify the resources and their need on the given fiber optic trainer kit. (02 Hrs.) 200. Make optical fiber setup to transmit and receive analog and digital data. (02 Hrs.) 201. Set up the OFC trainer kit to study AM, FM, PWM modulation and demodulation. (02 Hrs.) 202. Perform FM modulation and demodulation using OFC trainer kit using audio signal and voice link. (03 Hrs.) 203. Perform PWM modulation and demodulation using OFC trainer kit using audio signal and voice link. (03 Hrs.) 204. Perform PPM modulation and demodulation using OFC trainer kit using audio signal and voice link. (03 Hrs.)	Introduction to optical fiber, optical connection and various types optical amplifier, its advantages, properties of optic fiber, testing, losses, types of fiber optic cables and specifications. Encoding of light. Fiber optic joints, splicing, testing and the related equipment/measuring tools. Precautions and safety aspects while handling optical cables. (05 Hrs.)
Professional Skill 35 Hrs; Professional Knowledge 05 Hrs	Plan and Interface the LCD, LED, DPM panels to various circuits and evaluate performance. <b>(Mapped NOS: ELE/N8107)</b>	<b>Digital panel Meter</b> 205. Identify LED Display module and its decoder/driver ICs. (05 Hrs.) 206. Display a word on a two line LED. (06 Hrs.) 207. Measure/current flowing through a resistor and display it on LED Module. (06 Hrs.) 208. Measure/current flowing through a sensor and display it on a LED module (DPM). (06 Hrs.) 209. Identify LCD Display module and its decoder/driver ICs. (06 Hrs.) 210. Measure/current flowing through a resistor and display it. (06 Hrs.)	Different types of seven segment displays, decoders and driver ICs. Concept of multiplexing and its advantages. Block diagrams of 7106 and 7107 and their configuration for different measurements. Use of DPM with seven segment display. Principles of working of LCD. Different sizes of LCDs. Decoder/driver ICs used with LCDs and their pin diagrams. Use of DPM with LCD to display different voltage & current signals. (05 Hrs.)
Professional Skill 120 Hrs; Professional Knowledge 40 Hrs	Detect the faults and troubleshoot SMPS, UPS and inverter. <b>(Mapped NOS: ELE/N7202)</b>	<b>SMPS and Inverter</b> 211. Identify the components/devices and draw their corresponding symbols. (03 Hrs.) 212. Dismantle the given stabilizer and find major sections/ ICs components. (06 Hrs.)	Concept and block diagram of manual, automatic and servo voltage stabilizer, o/p voltage adjustment. Voltage cut-off systems, relays used in stabilizer. Block Diagram of different types of Switch mode power supplies and their working principles.

		<p>213. List the defect and symptom in the faulty SMPS. (05 Hrs.)</p> <p>214. Measure / Monitor major test points of computer SMPS. (07 Hrs.)</p> <p>215. Troubleshoot the fault in the given SMPS unit. Rectify the defect and verify the output with load. Record your procedure followed for trouble shooting the defects. (08 Hrs.)</p> <p>216. Use SMPS used in TVs and PCs for Practice. (05 Hrs.)</p> <p>217. Install and test the SMPS in PC. (05 Hrs.)</p> <p>218. Install and test an inverter. (05 Hrs.)</p> <p>219. Troubleshoot the fault in the given inverter unit. Rectify the defects and verify the output with load. (08 Hrs.)</p> <p>220. Construct and test IC Based DC-DC converter for different voltages. (08 Hrs.)</p> <p>221. Construct and test a switching step down regulator using LM2576. (08 Hrs.)</p> <p>222. Construct and test a switching step up regulator using MC 34063. (08 Hrs.)</p>	<p>Inverter; principle of operation, block diagram, power rating, change over period. Installation of inverters, protection circuits used in inverters. Battery level, overload, over charging etc. Various faults and its rectification in inverter. Block diagram of DC-DC converters and their working principals. (20 Hrs.)</p>
		<p><b>UPS</b></p> <p>223. Connect battery stack to the UPS. (07 Hrs.)</p> <p>224. Identify front panel control &amp; indicators of UPS. (05 Hrs.)</p> <p>225. Connect Battery &amp; load to UPS &amp; test on battery mode. (06 Hrs.)</p> <p>226. Open top cover of a UPS; identify its isolator transformers, the UPS transformer and various circuit boards in UPS. (08 Hrs.)</p> <p>227. Identify the various test point and verify the voltages on these. (05 Hrs.)</p> <p>228. Identify various circuit boards in UPS and monitor voltages at various test points. (05 Hrs.)</p> <p>229. Perform load test to measure backup time. (08 Hrs.)</p>	<p>Concept of Uninterrupted power supply. Difference between Inverters and UPS. Basic block diagram of UPS &amp; operating principle. Types of UPS : Off line UPS, On line UPS, Line interactive UPS &amp; their comparison UPS specifications. Load power factor &amp; types of indications &amp; protections Installation of single phase &amp; UPS. (20 Hrs.)</p>
<p>Professional Skill 60 Hrs; Professional Knowledge 15 Hrs</p>	<p>Identify, Test and verify characteristics of Photovoltaic cells, Modules, Batteries and Charge controllers. Install a solar panel, execute testing and evaluate performance by connecting the panel to the inverter. <b>(Mapped NOS: ELE/ N5902)</b></p>	<p>230A. Identify and Test an LED and a Photodiode to verify the photo emitting effect and light sensitivity. (04 hrs)</p> <p>230B. Test a Photo voltaic cell for different illumination levels and verify photovoltaic property. (04 hrs)</p> <p>230C. Plot I-V curve for photovoltaic cell based on the illumination at constant temperature. (04hrs)</p> <p>230D. Plot I-V curve for photovoltaic cell based on temperature at constant illumination. (04 hrs)</p>	<p>Semiconductor properties and types. P-type and N-type semiconductors, PN junction, etc.</p> <p>Conversion of solar radiation to electricity. Main materials used to develop solar cells (Silicon, Cadmium tellurides, etc.) Light sensitive properties of PN junction.</p> <p>Difference of photo electric and photo voltaic effects of a PN junction. PV cell characteristics, I-V curve, effects of temperature.</p>

		230E Test photovoltaic cell in sunlight at various angles of inclination and direction. (04 hrs)	Photovoltaic effect. Photo voltaic module: minimal functional specification, cells per module, max watts per module, maximum voltage at max power, maximum current at max power. (05)
		<p><b>Solar Power (Renewable Energy System)</b></p> <p>230F. Wire a solar controller to a battery storage station. (08 Hrs.)</p> <p>231. Connect storage batteries to a power inverter. (08Hrs.)</p> <p>232. Connect and test solar panel to the Inverter and run the load. (08Hrs.)</p> <p>233. Install a solar power to charge a rechargeable 12 V DC battery and find out the charging time. (08 Hrs.)</p> <p>234. Install a Solar Inverter. (08 Hrs.)</p>	<p>Need for renewable energy sources, Solar energy as a renewable resource. Materials used for solar cells. Principles of conversion of solar light into electricity. Basics of photovoltaic's cell. Module, panel and Arrays.</p> <p>Factors that influence the output of a PV module. SPV systems and the key benefits. Difference between SPV and conventional power. Solar charge controller or regulator and its role. Safety precautions while working with solar systems. (10 Hrs.)</p>
Professional Skill 30 Hrs; Professional Knowledge 10 Hrs	<p>Dismantle, identify the various parts and interface of a cell phone to a PC.</p> <p>Estimate and trouble shoot. <b>(Mapped NOS: ELE/N8107)</b></p>	<p><b>Cell phones</b></p> <p>235. Dismantle, identify the parts and assemble different types of smart phones. (04 Hrs.)</p> <p>236. Dismantle the cell phone/smart phone remove the key pad and clean it, test for the continuity of the matrix/tracks. (04 Hrs.)</p> <p>237. Interface the cell phone/smart phone to the PC and transfer the data card. (03 Hrs.)</p> <p>238. Flash the various brands of cell phone/smart phone (at least 3). (03 Hrs.)</p> <p>239. Format the cell phone/ smart phone for virus (approach the mobile repair shop/ service centre). (04 Hrs.)</p> <p>240. Perform the interfacing of cell phone/ smart phone to the PC and dismantle the cell phone and identify the power section and test its healthiness. (04 Hrs.)</p> <p>241. Find out the fault of basic cell phone system. Rectify the fault in ringer section and check the performance. (04 Hrs.)</p> <p>242. Replace various faulty parts like mic, speaker, data/ charging/ audio jack etc. (04 Hrs.)</p>	<p>Introduction to mobile communication. Concept cell site, hand off, frequency reuse, block diagram and working of cell phones, cell phone features.</p> <p>GSM and CDMA technology.</p> <p>Use IEMI number to trace lost/ misplaced mobile phone. (10 Hrs.)</p>

Professional Skill 15 Hrs; Professional Knowledge 05 Hrs	Check the various parts of a LED lights & stacks and troubleshoot. <b>(Mapped NOS: ELE/N9302)</b>	<b>LED Lights</b> 243. Dismantle the LED light, identify the connections of LEDs stacks, protection circuits, regulator. (03 Hrs.) 244. Identify the rectifier, controller part of LED lights. (03 Hrs.) 245. Make series string connection of six LED's and connect four Series strings in parallel. (03 Hrs.) 246. Connect to such parallel sets in Series to create a matrix of LED's. (03 Hrs.) 247. Apply suitable voltage and check Voltage across series strings. (03 Hrs.)	Types of LED panels used in various lighting applications. Stacking of LEDs.
Professional Skill 50 Hrs; Professional Knowledge 15 Hrs	Identify, operate various controls, troubleshoot and replace modules of the LCD/LED TV & its remote. <b>(Mapped NOS: ELE/N3102)</b>	<b>LCD and LED TV</b> 248. Identify and operate different Controls on LCD, LED TV. (05 Hrs.) 249. Identify components and different sectors of LCD and LED TV. (05 Hrs.) 250. Dismantle; Identify the parts of the remote control. (05 Hrs.) 251. Dismantle the given LCD/LED TV to find faults with input stages through connectors. (05 Hrs.) 252. Detect the defect in a LED/LCD TV receiver given to you. Rectify the fault. (10 Hrs.) 253. Troubleshoot the faults in the given LED/LCD TV receiver. Locate and rectify the faults. (10 Hrs.) 254. Test LED/LCD TV after troubleshooting the defects. (05 Hrs.) 255. Identify various connectors and connect the cable operators external decoder (set top box ) to the TV. (05 Hrs.)	Driving of LED stacks. (05 Hrs.) Difference between a conventional CTV with LCD & LED TVs. Principle of LCD and LED TV and function of its different section. Basic principle and working of 3D TV. IPS panels and their features. Different types of interfaces like HDMI, USB, RGB etc. TV Remote Control –Types, parts and functions, IR Code transmitter and IR Code Receiver. Working principle, operation of remote control. Different adjustments, general faults in Remote Control. (15 Hrs.)

Electronics Mechanic - Electronic Cables and Connectors

Identify various types of cables used for Audio, Video and RF signal with different input output socket

**Objectives :** At the end of this exercise you shall be able to

- identify different types of cables used for audio, video and RF signal
- note the details of identified audio, video and RF cables and sockets.

Requirements		
Tools/Equipments/Instruments		Materials/Components
• Trainees tool kit	- 1 Set.	• Different types of cables used for audio/video/RF, shielded/coaxial, ribbon, CAT 6, telephone cable-marked with labels - 1 No each. • RCA plug and socket, phono jack, BNC - as reqd. • XLR, F-connector, RJ45, RJ11 plug & socket - 1 No each.
• Digital multimeter with probes	- 1 No.	
• Magnifier with lamp	- 1 No.	
• <b>Aids:</b> Diagram/chart showing all the details of types of audio/video socket/connectors and cables	- 1 No.	

**Note:** The instructor has to label the cables utilized for this practical with alphabets and sockets/connectors with numbers

PROCEDURE

TASK 1: Identification of cables used for audio/video/RF signal

- 1 Pick one of the labelled cables displayed by the Instructor.
- 2 Record the details of the identified cables in Table 1.
- 3 Repeat the above steps for all remaining labelled cables.
- 4 Get the recorded information checked by the Instructor.

Table 1

Sl.No.	Details of cables		Name of the wires	Remarks
	No. of cores	No. of insulating layer		
1			Shielded wire	
2			Screened wire	
3			Coaxial cable	
4			Ribbon cable	
5			Optical fiber cable	
6			CAT 6 cable	
7			RJ11 telephone cable	
8			Two core speaker wire	
9			Digital optical audio	
10			Video cable	
11			Fibre Optic cable	
12			Ethernet cable	

**TASK 2: Identified audio, video, RF cables and sockets**

- 1 Pick one of the labelled connector / plug / socket from the selected lot displayed by the Instructor
- 2 Record the name and other details of identified audio/ video/ RF socket/connector/plug in Table 2.
- 3 Repeat the steps for all the remaining labelled sockets/connectors/plug.
- 4 Get the recorded information checked by the Instructor.

**Table 2 - Details of audio / video / RF sockets/plugs**

Sl.No.	Label number	Name of the plug / socket	Application
1	RCA plug		
2	RCA socket		
3	Phono jack		
4	Phono jack socket		
5	XLR - plug - socket		
6	BNC - plug - socket		
7	F - connector plug - socket		
8	RJ 45 plug / socket		
9	RJ 11 plug / socket		

**Identify suitable connectors, solder / crimp/ terminate and test the cable sets**

**Objectives :** At the end of this exercise you shall be able to

- to prepare of audio cable using RCA plug to RCA plug
- to prepare of audio cable using XLR to phone Jack (6.5 mm / 3.5 mm)
- to prepare of BNC to RCA cable.

Requirements		
<b>Tools/Equipments/Instruments</b>		<b>Materials/Components</b>
<ul style="list-style-type: none"> <li>• Trainees tool Kit - 1 Set.</li> <li>• Magnifier with lamp - 1 No.</li> <li>• Digital Multimeter with probes - 1 No.</li> <li>• Crimping tool (HT 301 A/ 301C) - 1 No.</li> <li>• Rotary cable stripper - 1 No.</li> <li>• Soldering iron-25watt/240v - 1 No.</li> <li>• <b>Aids:</b> Chart showing all types of audio/video sockets and connectors - 1 No.</li> </ul>	<ul style="list-style-type: none"> <li>• RCA plug and socket, phono jack-stereo (6.5mm/3.5mm),BNC / XLR socket and plug, F-connector - as reqd.</li> <li>• Single/Two core shielded wire - 2m.</li> <li>• Coaxial cable-RG 6/ RG59 - as reqd.</li> <li>• Rosin cored solder and flux - as reqd.</li> <li>• PVC sleeves -2 mm dia - as reqd.</li> </ul>	

**PROCEDURE**

**TASK 1: Preparation of audio cable using RCA plug to RCA plug**

1 Pick a RCA plug, visually check and remove the rear portion of the housing by unscrewing it; Refer the exploded view as shown in Fig 1.

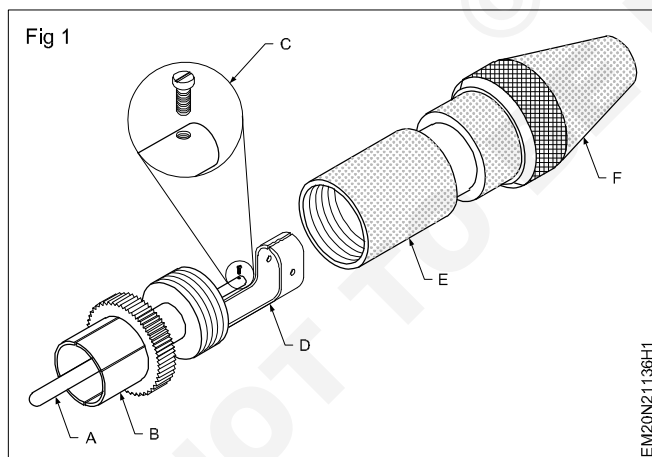

- 2 Scrape/ clean any oxide layer on the terminal lug using knife and tin the terminal.
- 3 Take the single core shielded cable, skin the outer insulation for 2cm length and dress the leads/screen terminals.
- 4 Apply a thin layer of flux on the core and shield leads and tin these terminals.

- 5 Insert a piece of PVC sleeve onto the tinned portion of the inner conductor (over the exposed portion to avoid any accidental contacts or shorts) and screw/solder it to the plug terminal-C.
- 6 Solder the screen lead (outer conductor) to the other terminal-D, on the plug as shown in Fig 1.
- 7 Inspect the soldered joint and ensure continuity from the socket end to the cable end using ohmmeter.
- 8 Insert the outer housing of the plug (E to F) through the cable, pull and tighten it.
- 9 Prepare the other end of the cable, tin the terminals of the RCA plug and solder as shown in Fig 2.

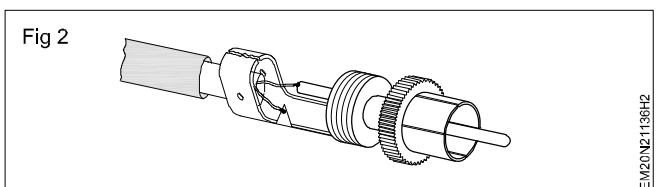

- 10 Check the continuity and ensure that there is no short circuit between the core and the screen lead terminals.
- 11 Get the prepared RCA to RCA cable checked by the Instructor.

## TASK 2 : Preparation of audio cable using XLR to Phono jack (6.5 mm / 3.5 mm)

- 1 Pick the XLR plug connector, identify the terminals with reference to Fig 1

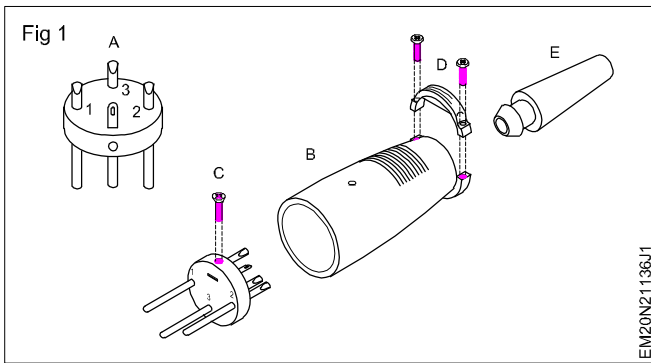

- 2 Scrape / clean the terminals and tin them.
- 3 Take the two core shielded cable, skin the outer insulation for 2 cm length using cable stripper.
- 4 Open the copper braid/shield, separate the two cores, and twist the bunch of shield conductors into one.
- 5 Tin the end of all three (two cores and shield) terminals.
- 6 Solder the screen lead of the prepared cable to the pin No.3 of the XLR connector.

- 7 Solder the two cores to pin 1 and 2.
- 8 Inspect and test the soldered terminals with the cable has no short circuit.
- 9 Pick the phono jack plug and solder the signal leads correctly as shown in Fig 2
- 10 Get the work checked by the Instructor.

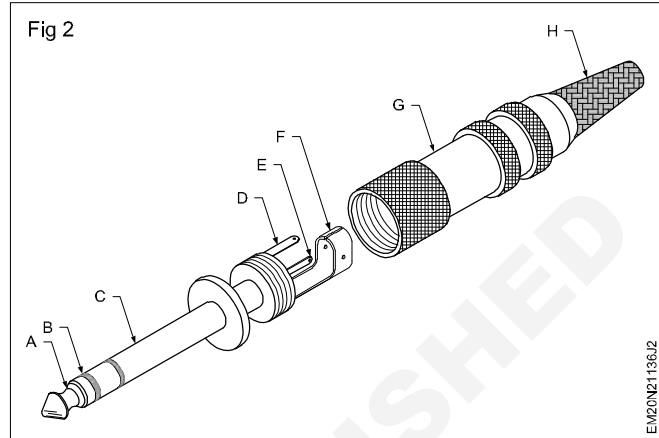

## TASK 3 : Preparation of BNC to RCA cable

- 1 Select a BNC male type plug, refer to the Fig 1 and remove the inner parts from the housing.

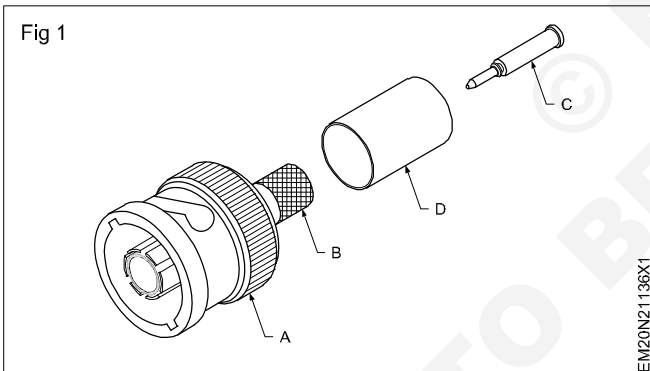

**Note: Keep the removed parts safely to re-assemble them after crimping the cable.**

- 2 Take the coaxial cable, mark 1.5 cm length and using cable stripper, skin the outer PVC insulation.
- 3 Insert the coaxial cable into the ferrule (D) and fold the shielding without disturbing the mesh formation. Push the shielding backwards over the sheath so that the inner insulation and core is visible as shown in Fig 2 (a) & (b).
- 4 Remove the styroflex insulation for 5mm length from the tip using blade; refer to Fig 6, insert the core into the center pin (C) of the BNC plug and crimp this connection using crimping tool.
- 5 Get the crimped pin checked by the Instructor.

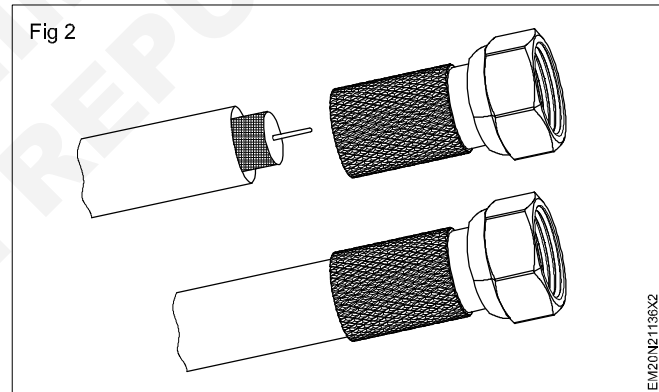

- 6 Insert the crimped pin into the connector housing (A) till the center pin comes out to the level position and the styroflex insulation fits tightly in the connector.
- 7 Push the shield and spread it over the knurled outer portion (B) of the rear end on the connector.
- 8 Pull the ferrule (D) already inserted, move it on the shield spread over the knurling.
- 9 Make the ferrule (D) sit over the shield uniformly and crimp this portion using correct slot hole on the crimping tool.
- 10 Use multimeter and test for any short circuit between the pin and the body of the BNC connector.
- 11 Get the work checked by the Instructor.
- 12 Take a RCA plug and solder it on the other end of the coaxial cable following steps 1 to 7 of Task 1.
- 13 Get the BNC to RCA cable checked by the Instructor.



**Check the continuity as per the marking on the connector for preparing the cable set**

**Objectives :** At the end of this exercise you shall be able to

- identify the marking on the HDMI cable terminals
- check the continuity of the SPDIF optical cable.

Requirements		
Tools/Equipments/Instruments		Materials/Components
<ul style="list-style-type: none"> <li>• Trainees tool kit</li> <li>• Digital multimeter with probes</li> <li>• LED torch light -3 volt</li> <li>• Magnifier with lamp</li> <li>• <b>Aids:</b> HDMI type-A socket and plug, SPDIF optical cable terminal diagram</li> </ul>	<ul style="list-style-type: none"> <li>- 1 Set.</li> <li>- 1 No.</li> <li>- 1 No.</li> <li>- 1 No.</li> <li>- 1 No.</li> </ul>	<ul style="list-style-type: none"> <li>• Rosin cored solder - as reqd.</li> <li>• HDMI type-A cable - 1 No.</li> <li>• HDMI type-A socket and plug - 1 No.</li> <li>• SPDIF optical cable Hook-up wire 0.5m - 1 No.</li> <li>• Hookup wire - 0.5 m.</li> </ul>

**PROCEDURE**

**TASK 1 : Checking the HDMI cable**

**Note:** Cut the hook-up wire into two pieces and skin both the ends. Attach one end of the hook-up-wire by twisting on the pin of DMM test probe and leave the other end open. Do this for the other probe also.

- 1 Mark both the terminals of HDMI cable as A and B.
- 2 Pick the HDMI cable end-A and keep the plug terminal in horizontal position.
- 3 Refer to the Fig 1 (a) and (b), identify the pin no 1.
- 4 Select the ohmmeter range on the DMM, use the common lead, and insert the hook up wire end contact Pin No. 1
- 5 Use the other lead of the DMM with hook-up wire, touch the pin no 1 on the B end of the HDMI cable
- 6 Observe the reading on the DMM and record the readings in the Table-1

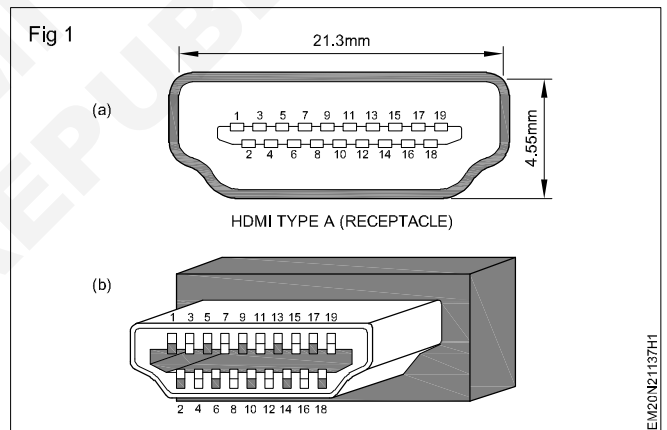

- 7 Repeat the steps for all the remaining pins of the HDMI cable.
- 8 Cross check any short circuit with other pin connections.
- 9 Get the work checked by the Instructor.

Table 1

SI.No	Pin no of the HDMI cable (end A-B)	Ohm meter reading in Ohms	Result	Remaks
1				
2				
3				
4				
5				
6				
7				
8				
9				
10				
11				
12				
13				
14				
15				
16				
17				
18				
19				

**TASK 2 : Checking the SPDIF cable**

**Note:**  
**1 Ensure that there is no physical damage to the SPDIF cable used for this Task.**  
**2 Remove the cap if any on the optical fiber cable end before proceeding the step**

- 1 Mark one end of the SPDIF (optical fiber cable) as terminal-A and other end as terminal B.
- 2 Arrange a small pointed light beam from LED torch.
- 3 Keep the optical fiber cable end point on the terminal - A of SPDIF cable under the LED light rays as shown in Fig 1 a & b.
- 4 Observe the other end of the cable for any visible light spot penetrated through the cable.

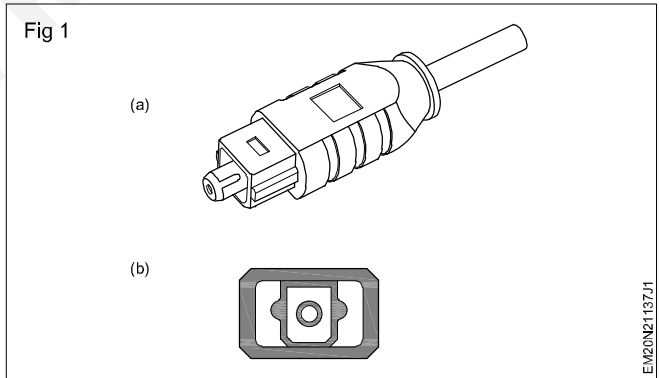

- 5 Record the observation in Table 2.
- 6 Reverse the SPDIF cable terminals under the LED light and repeat steps 3 to 5.
- 7 Get the work checked by the Instructor.

Table 2

SI.No	LED light applied on	Result	Remarks
1	Terminal - A		
2	Terminal - B		

**Identify and select various connectors and cables inside the CPU cabinet of PC**

**Objectives :** At the end of this exercise you shall be able to

- identify different types of external ports / connectors used in computer system
- identify different ports / slots on the motherboard of computer.

**Requirements**

**Tools/Equipments/Instruments**

- Multimedia computer system - 1 Set.
- Digital multimeter with probes - 1 Set.
- Trainees tool kit - 1 Set.
- **Aids:** Charts - 1 showing all types of internal & external ports, cables & connectors used in computer system - 1 No.
- Chart 2 showing all types of slots and ports on computer mother board - 1 No.

**Materials/Components**

- Set of cables used to connect peripheral devices to a computer- externally - 1 Set.
- Set of cables used to connect ports and slots on a mother board - internally - 1 No.

**Note: The instructor has to sequentially label all the external ports/sockets on the front panel of the CPU using numbers.**

**TASK 1 : Identification of external ports of multimedia computer system**

- 1 Select and identify the first labelled external port on the CPU with reference to Fig 1.
- 2 Refer to the chart - 1 and record and application/ uses details of the identified item in Table 1.
- 3 Repeat the above step for all the remaining labelled ports on the rear panel and front panel of the CPU.
- 4 Identify the labelled ports on the monitor, record the details in Table 1.
- 5 Get recorded information checked by the instructor.

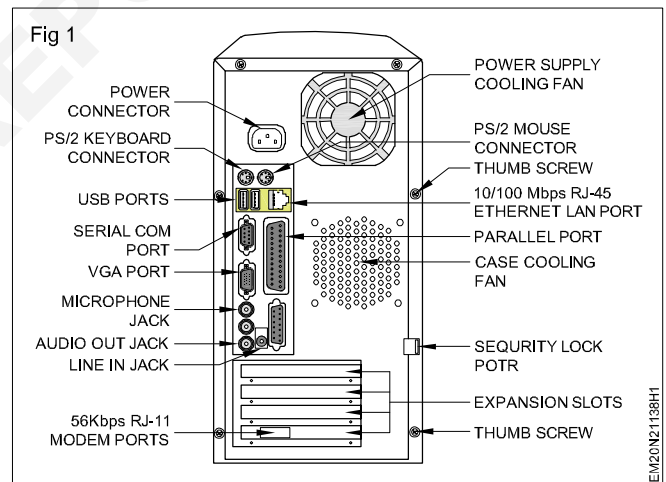

**TASK 2 : Identification different of ports /slots on mother board of computer**

**Note: 1 The instructor has to label all the cables from SMPS, CPU cooler, optical drive, HDD, front panel USB socket, Mic, Speaker, Status LED indicators, Power ON switch etc sequentially using alphabets. 2. Mark all the sockets/slots on the mother board other than the parts of rear panel of CPU.**

- 1 Remove the fixing screws of CPU; open the side cover of the CPU and keep aside carefully.

**Note: keep the removed screws and cover safely to re-assemble them after identification of internal ports.**

- 2 Identify all the labelled internal ports on the mother board as shown in Fig 1.

**Note: Draw additional rows and columns as per requirement/ the computer system**

Fig 1

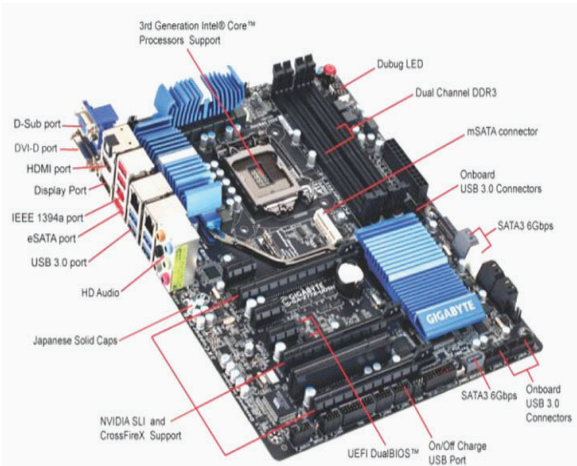

- 3 Select the first labelled port/ slot, refer to the chart-2, identify the name, type etc. and record them in Table-2.
- 4 Repeat step 3 for all the remaining ports/ slots on the motherboard.
- 5 Get the recorded observations checked by the instructor.

Table 1 Showing internal & external ports of computer system.

Label No.	Name of the Port/ Socket	Location of the port/ Type No	CPU/Monitor	Application/ Uses	Remarks
1					
2					
3					
4					
5					
6					
7					
8					
9					

Table 2

Label No.	Name of the Port/slot	Type of cable/ Code No/	No of Pins	Application Use	Remarks
1	2	3	4	5	6
2					
3					
4					
5					
6					
7					
8					
9					
10					

**Identify the suitable connector and cable to connect a computer with a network switch and Prepare the crossover cable to connect two network computers**

**Objectives :** At the end of this exercise you shall be able to

- identify connector/ports used in network switch
- prepare of straight cable to connect computer with network switch
- prepare the cross-over network cable using CAT6 cable to connect two computers in network

Requirements				
<b>Tools/Equipments/Instruments</b>				
• RJ45 Crimping tool	- 1 No.	• Cable stripper	- 1 No.	
• Network cable tester	- 1 No.	<b>Materials/Components</b>		
• Digital Multimeter with probes	- 1 No.		• CAT6 cable	- 2 mtr.
• Trainees tool kit	- 1 Set.		• RJ45 plug	- 4 Nos.
• Working personal computer	- 2 Nos.		• Strain relief cable boot (optional)	- 4 Nos.
• 8 port network switch	- 1 No.			

**PROCEDURE**

**TASK 1: Identification of connector/ports used on network switch**

- 1 Collect the 8 port network switch from the Instructor
- 2 Observe the front panel controls, ON/OFF switch, ports/sockets and their types of network switch unit as shown in Fig 1

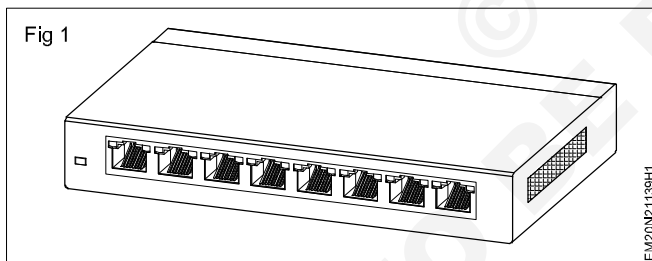

- 3 Record the observation in Table - 1
4. Get the work checked by the Instructor

**Note: The Instructor has to provide the 8 port network switch and guide the trainees to handle the electronic device**

Table - 1

S. No.	Controls No. of Ports/ Sockets/Types	Cable

**TASK 2: Preparation of straight cable to connect computer with network switch**

**Note: Instructor has to arrange the required length of CAT6 cable for straight cable and cross-over cable, the tool for crimping the RJ45 plug/jacks. Ensure the correct working of crimping tool.**

- 1 Collect and check all the tools and RJ45 connectors required for making network cables.
- 2 Take the CAT6 cable, mark 2.5 cm from one end of the

cable as shown in Fig 1 a,b and remove the cable jacket/insulation using cable stripper / crimping tool.

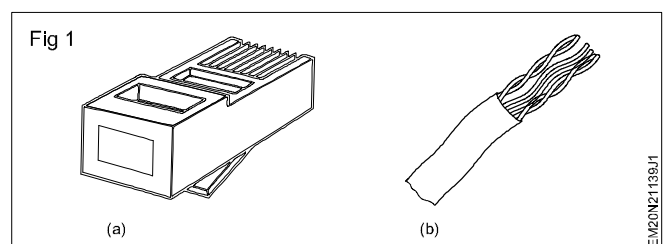

**Note:**

- 1 If strain relief boot is to be used, insert and slide on the strain, relief boot into the CAT6 cable before crimping.
- 2 Do not remove any insulation from the conductors of the cable pairs.

- 3 Bend each twisted pairs on four sides and cut-off the soft supporting member-spleen and the string as shown in Fig 2.

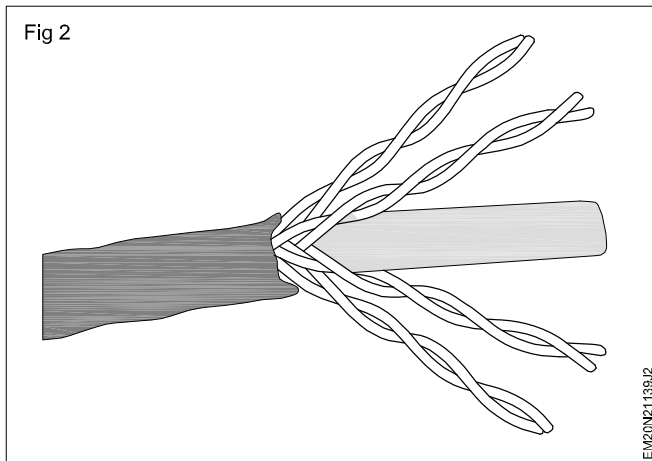

- 4 Untwist the wire pairs and separate all the wires as shown in Fig 3 (a) and (b).

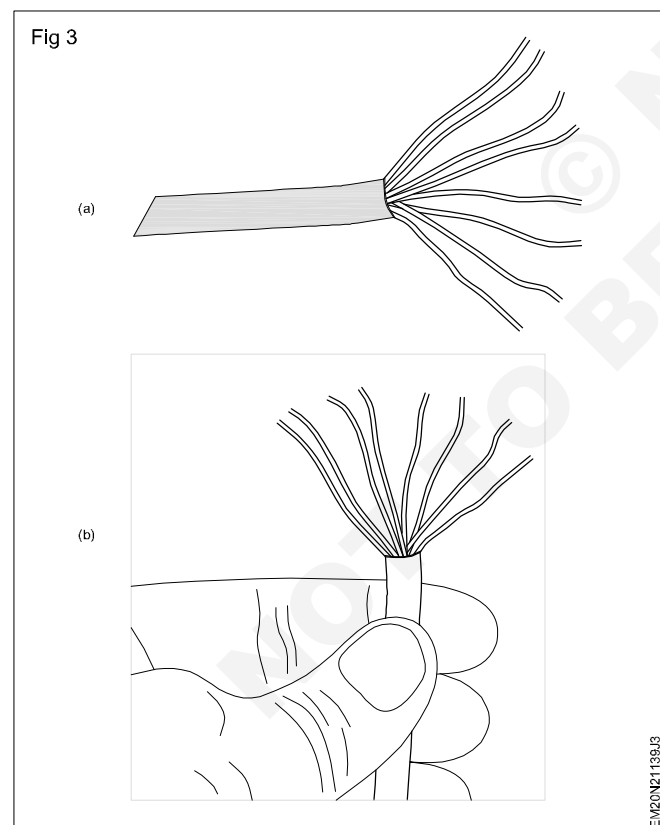

- 5 Straighten the wires and arrange them from left to right in the order as shown in cable colour Chart-1 for straight cable crimping.

**Wire colour Chart-1 for straight cable**

Pin no.	Cable end-A Wire colour	Cable end-B Wire colour
1	white-green	white-green
2	green	green
3	white-orange	white-orange
4	blue	blue
5	white-blue	white-blue
6	orange	orange
7	white-brown	white-brown
8	brown	brown

- 6 Grasp the wires firmly between your fingers flatly and cut a few mm so that all the wires are of the same length as shown in Fig 4.

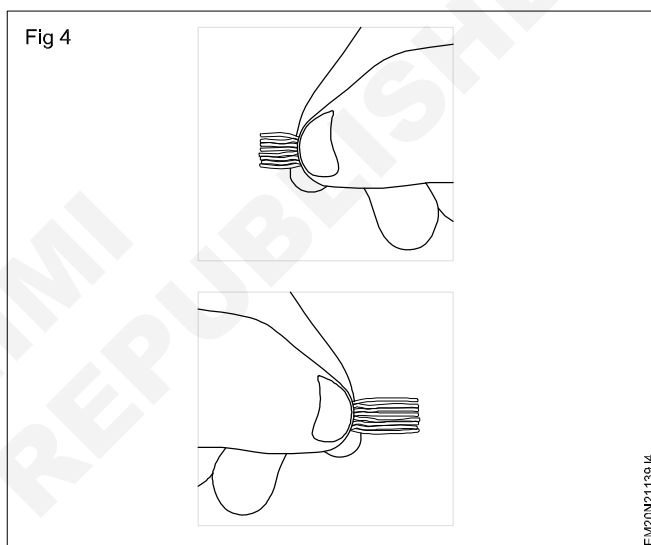

- 7 Insert the prepared wires into the RJ45 plug as shown in Fig 5 (a) and (b).

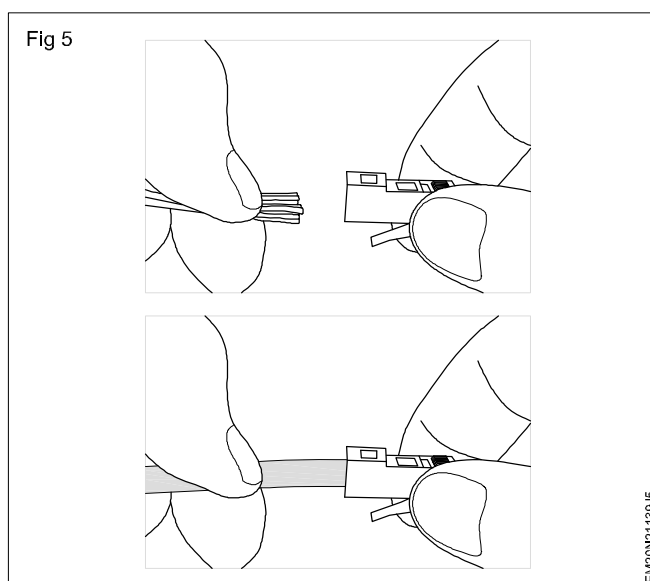

- 8 Get the colours of wires inserted into RJ45 plug for crimping straight cable checked by the Instructor.

9 Insert the jack and wire combo into RJ45 slot of the crimping tool as shown in Fig 6.

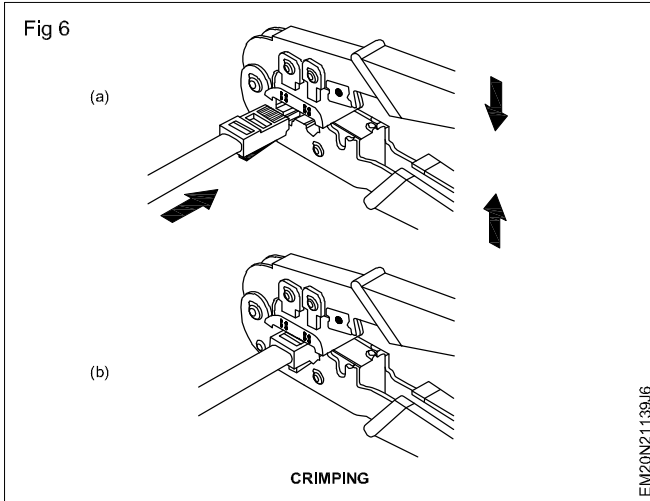

**Note: The crimping tool may come with additional slots for crimping RJ11-telephone wires also.**

10 Press the crimping tool a bit harder so that the pins of the jack go inside and contacting the core of each wire simultaneously.

**Note: Pins should not be protruding after crimping.**

- 11 Get the crimped RJ45 plug checked by the Instructor.
- 12 Take the other end of the CAT6 cable, follow steps 2 to 10 and crimp the RJ45 plug.
- 13 Connect the prepared straight cable into the Network cable tester, switch ON and record the observation of the LEDs glowing in Table-1.

**Observation Table -1**

Pin no.	Status of LED	Remarks
1		
2		
3		
4		
5		
6		
7		
8		

14 Get the crimped straight cable checked by the Instructor.

**TASK 3: Preparation of cross-over cable to connect two computers**

- 1 Take the CAT6 cable and repeat step 2 to 4 of Task 2.
- 2 Straighten the wires and arrange them from left to right in the order as shown in wire colour Chart-2 for cross-over cable.

**Wire colour Chart-2 for cross-over cable**

Pin No.	Cable end-A Wire colour	Cable end-B Wire colour
1	white-green	white-orange
2	green	orange
3	white-orange	white-green
4	blue	white-brown
5	white-blue	brown
6	orange	green
7	white-brown	blue
8	brown	white-blue

**Note: If strain relief boot is to be used, slide on the strain relief boot into the CAT6 cable.**

3 Grasp the wires firmly between the fingers flatly and cut a few mm so that all the wires are of the same length as shown in Fig 1 - 4 of Task 2.

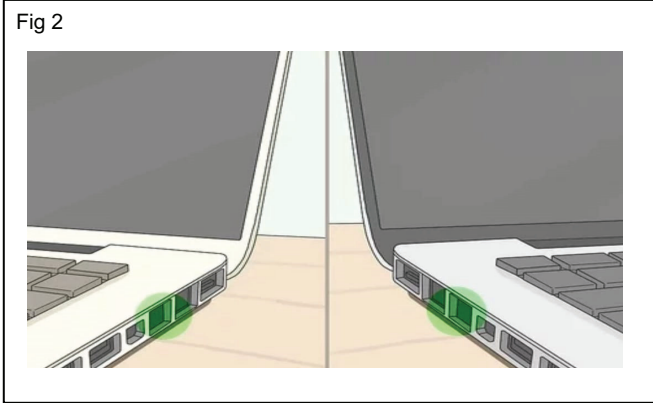
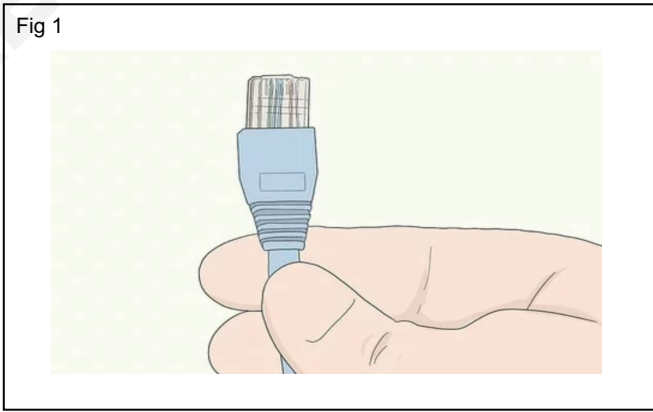
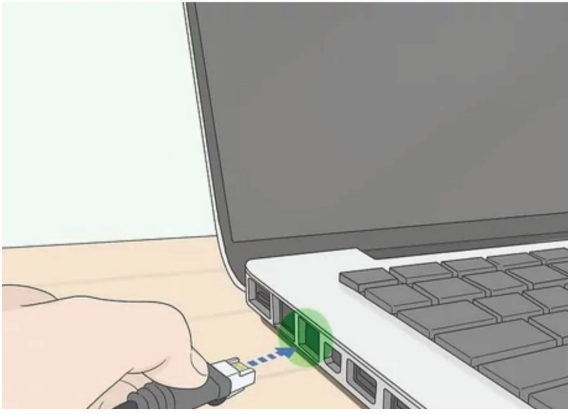

Fig 3



- 4 Repeat steps 7 to 10 of Task 2 and get the crimped RJ45 plug checked by the Instructor.
- 5 Take the other end of CAT6 cable, follow above steps 2 to 4 and crimp the RJ45 plug.
- 6 Connect the prepared cross-over cable into the network cable tester, switch ON and record the observations in Table 2.

**Observation Table -2**

Pin no.	Status of LED	Remarks
1		
2		
3		
4		
5		
6		
7		
8		

- 7 Get the work checked by the Instructor.

Fig 4

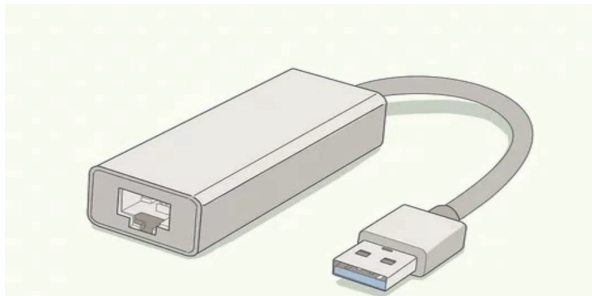



**Demonstrate various parts of the system unit and motherboard components**

**Objectives :** At the end of this exercise you shall be able to

- identify drives HDD, CD ROM drive, DVD-drive, USB pen drive and various secondary storage devices and their usual maximum capacity for storage of information.

Requirements			
<b>Tools/Instruments</b>			
• Screw driver set	- 1 No.	• Extra SATA and PATA Hard-Disk Drive compatible cables	- as reqd.
• Digital Multimeter	- 1 No.		
<b>Equipments</b>		<b>Materials</b>	
• Desktop PC with mouse & keyboard	- 1 No.	• CMOS Battery	- 1 No.
		• SATA Cable	- 1 No.

**PROCEDURE**

**TASK 1 : Identification of various drives and secondary storage devices in a PC**

- 1 Remove the cover of the PC system unit
- 2 Observe hard disk drive type either SATA or PATA and its capacity, power connection cable, its voltage column colour code at cable with voltage supply used.
- 3 Identify desktop PC HDD, CD-R/W drive & DVD - ROM drive, its connections for both type SATA and PATA hard disk drive and its connection using straight cables, cross cable for making it primary master either, primary slave or secondary master / slave using suitable data cable.
- 4 Identify connection point at mother board for SATA HDD, PATA HDD, CD R/W drive, and DVD R/W used in desktop PC (Figs 1 - 4)
- 5 Identify different type cable connections used for different drive.
- 6 Identify polarity of connector to avoid wrong connection.
- 7 Fix the cabinet, switch on supply and check the status of computer.
- 8 Identify various components like (Resistors, capacitors etc.) & SMD components placed on mother board.

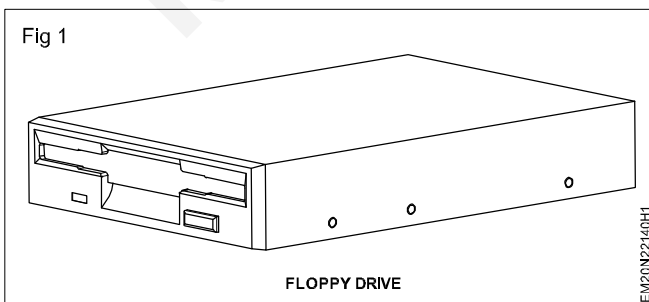
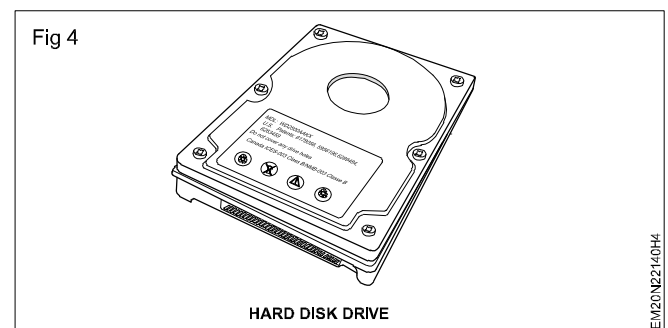
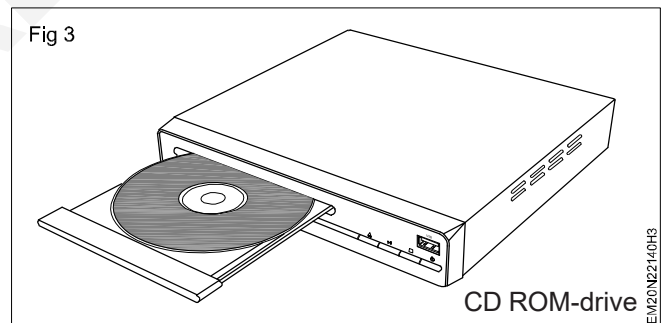
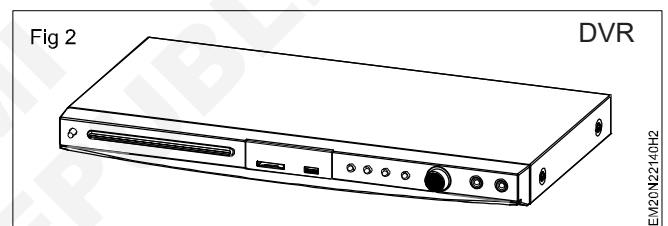

**Identify various computer peripherals and connect it to the system**

- Objectives :** At the end of this exercise you shall be able to
- identify different controls on the processing unit cabinet
  - identify various input/output devices connected to PC.

**Requirements**

**Hardware and software**

- |   |  |
|---|--|
| <ul style="list-style-type: none"> <li>• Identical PCs with labelled ports, connection cables (could even be dummy) - as reqd.</li> <li>• I/O devices such as Keyboard, Mouse Monitor, Printer, Multimedia, Speaker, CD Drive, DVD Drive and Microphone - as reqd.</li> </ul> | <ul style="list-style-type: none"> <li>• Screw driver set and Allen key (depending upon the type of fixing used with connectors) - as reqd.</li> <li>• Sticking labels - as reqd.</li> </ul> |
|---|--|

- One PC along with one set of I/O devices will be used for demonstrating by the instructor.
- Two PC's each with one set of I/O devices will be used by two groups of trainees (each group not exceeding a maximum of ten trainees)

**PROCEDURE**

**TASK 1 : Identify the major components, Controls and Ports seen on the processing unit cabinet**

A The instructor has to demonstrate the uses of the indicators, switches, controls and Ports external to the processor unit found on the cabinet of the processor unit as per the list given below (Fig 1).

- Mains power-on switch
- Power on LED
- Reset button
- HDD busy LED
- Floppy Disk Drive, Disk eject button, Disk busy LED
- CD Drive, CD busy/reading LED, controls and sockets found on the disk drive
- Ports for connecting the Mouse and other devices
- Printer port, keyboard connector, monitor connector
- Speaker socket
- Universal serial bus port (USB)

- Function of each port
- Basic specification of DVD and CD drive
- Basic symptoms of healthy processor (fan sound, power light, any unusual noise/smell etc)
- Precaution to be taken while using the computer
- Precaution to be taken while operating DVD and CD drives
- Precaution to be taken while handling DVD and CD
- Precaution to be taken while handling and storing the processor unit

While demonstrating, the following points should be Highlighted and stressed.

- Function of each switch
- Function of each LED indicator
- Function of each visible device

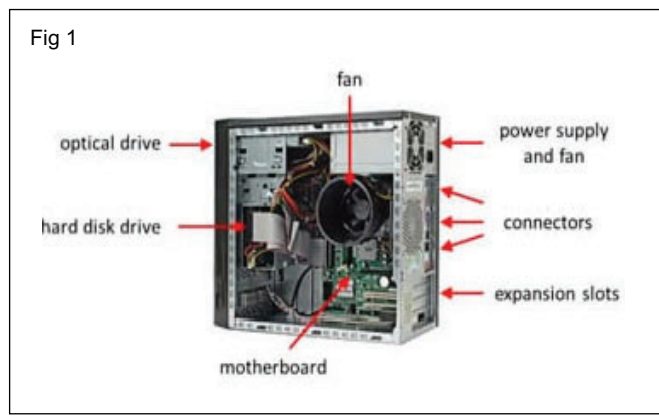

**TASK 2 : Identification of the I/O devices connected to PC**

A. The Instructor has to demonstrate the controls of different I/O devices connected to PC as per the list (Fig 1 & 2)

- The Monitor
- The Printer
- The Mouse
- The Keyboard
- Multimedia speakers
- The microphone
- The scanner
- The Modem
- Any other I/O devices available at the time of conducting this demonstration.

While carrying out the demonstration, the instructor has to ensure the following points are highlighted,

Precautions to be taken for handling the PC system.

- 1 Record the I/O devices connected to the computer setup given to you
- 2 Record the manufacturer, type name and model name/ number of the I/O devices connected
- 3 Record against each device whether it is an input device or an output device
- 4 Get the recorded details of the devices checked by the instructor.

Fig 1



Fig 2



**Disable certain functionality by disconnecting the concerned cables SATA / PATA**

**Objectives :** At the end of this exercise you shall be able to

- **disable the functionality from device manager**
- **disconnecting the devices from the mother board.**

Requirements			
<b>Tools/Equipments/Instruments</b>			
• Trainees tool kit	- 1 Set	• Extra SATA and PATA Hard-Disk Drive compatible cables	- as reqd
• Digital multimeter with probes	- as reqd	<b>Materials/Components</b>	
• Static charge earthing cable system	- as reqd	• Sticking labels for marking cables & connectors	- as reqd
• Desktop PC with mouse & keyboard	- as reqd		

**PROCEDURE**

**TASK 1: Disabling the device/port/ USB/from the device manager**

- 1 Click start menu of windows desktop screen
- 2 Open control panel in start menu
- 3 Select and open device manager
- 4 Now, locate device or port or USB or connector to enable or disable.
- 5 After finding the device or port or USB or connector, select it and make mouse right click on device icon.
- 6 Select and open the properties of device in right click menu.
- 7 In properties window, select the drivers tab
- 8 Now click the button of disable for disabling the device.
- 9 Click the OK button on window
- 10 Now disconnect the concerned device connected to connector
- 11 Check the worksheet by the instructor

**TASK 2 : Disconnecting the devices from the motherboard**

- 1 Open the cabinet of the desktop PC
- 2 Identify the port or USB cable connections on motherboard by using motherboard diagram.
- 3 Unlock if any protection screws are present on cable connectors
- 4 Remove the cable connectors and check the status on desktop.

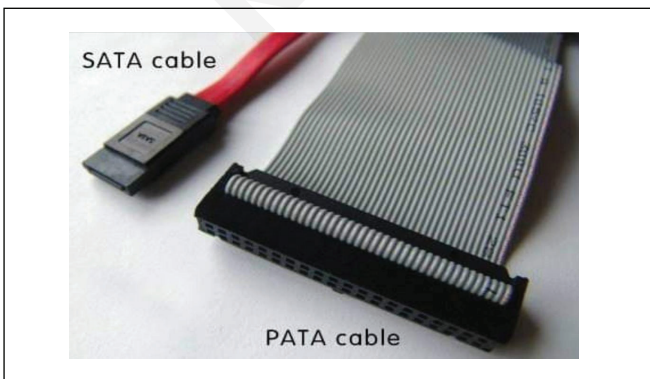
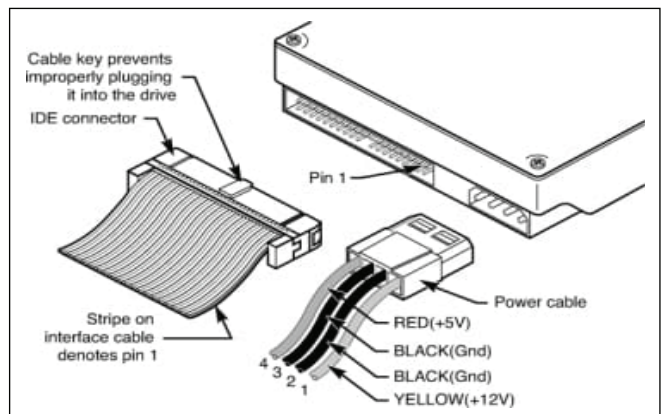

- 5 Get the work checked by the Instructor.

**Replace the CMOS battery and extend a memory module**

**Objectives :** At the end of this exercise you shall be able to

- identify the battery information and type of battery
- remove the battery
- replace the battery
- identify the location of RAM (S1mm/D1mm)
- replace and extend the RAM.

Requirements	
<p><b>Tools/Equipments/Instruments</b></p> <ul style="list-style-type: none"> <li>• Watch-maker screw driver set - 1 No.</li> <li>• Screw driver set - 1 No.</li> <li>• Desktop P.C. with mouse and keyboard - 1 No.</li> <li>• Extra mother board of computer - 1 No.</li> </ul>	<p><b>Materials/Components</b></p> <ul style="list-style-type: none"> <li>• Quick guide or manual for motherboard of P.C. showing diagram &amp; its components - 1 No.</li> <li>• CMOS battery - 1 No.</li> <li>• Different types of RAM suitable to the motherboard - as reqd.</li> <li>• Quick installation guide - 1 No.</li> </ul>

**PROCEDURE**

**TASK 1 : Identification of battery and type**

- 1 Open the chassis/case of computer
- 2 Find the battery location on motherboard by referring quick guide or manual
- 3 Find the type of cell (example: Coin Cell) as shown in Fig 1.
- 4 Note down information available on cell like voltage, size or package etc

- Most of the batteries will be like CR2000 etc.**
- 5 Identify type of socket (socket with upper tab, socket with lateral, inside socket laying) provided on battery
  - 6 Get the work checked by the Instructor.

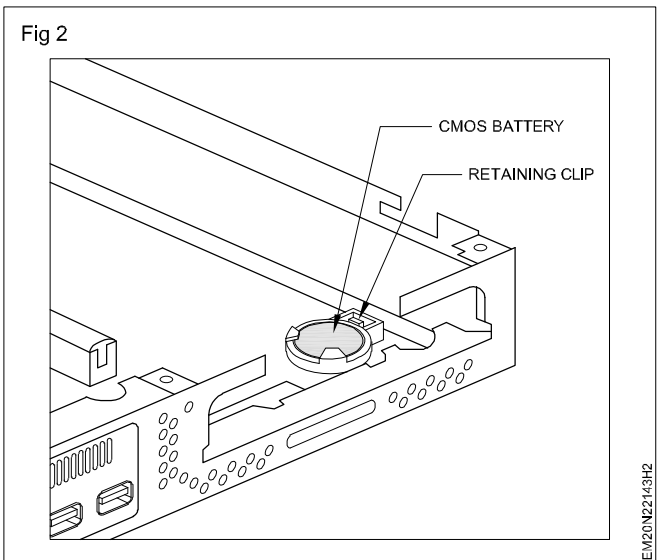

**TASK 2 : Removal of the battery**

- 1 Remove or side the wires laying on battery.
- 2 Draw back the tabs surrounded by battery by using small screw driver or watch maker screw driver.

- Use suitable watchmaker screw driver for tap screw lock removing.**
- 3 Gently pull the battery and remove the battery as show n in Fig 1.

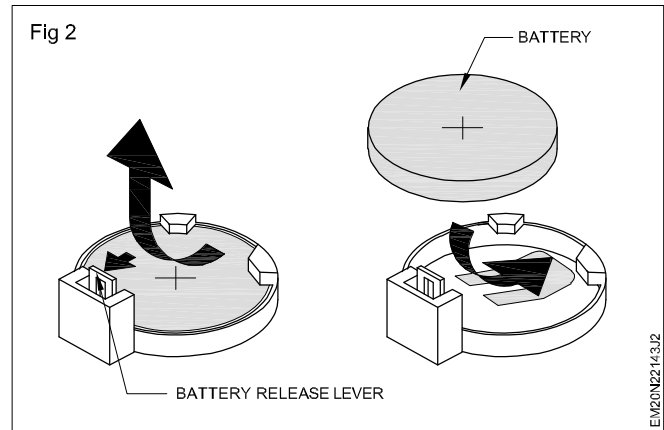
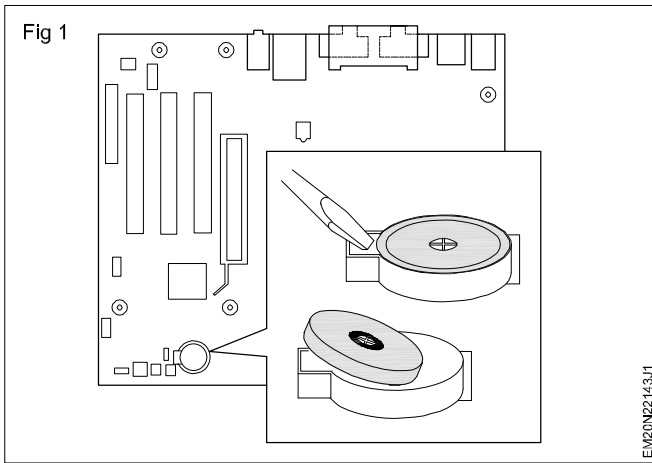

### TASK 3 : Replacing the battery

- 1 Identify the polarity of battery by using symbol or indicator.
- 2 Identify the polarity of socket by using symbol or indicator.
- 3 Place the battery on the socket and press gently to lock tabs of socket as shown in Fig 1.
- 4 If it is screw lock tab, hold the tab and make screw the tab.
- 5 Get the work checked by the Instructor.

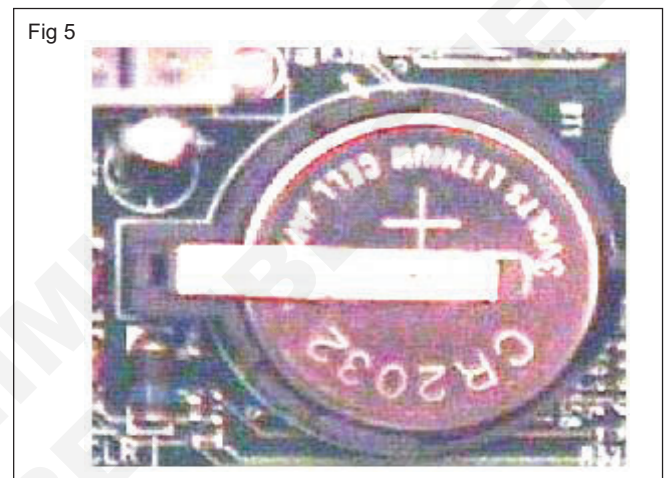

### TASK 4 : Identification of RAM (SIMM/DIMM)

- 1 Open cover of computer system unit using four head screw driver.
- 2 Note the mother board information like type of board, type of RAM (SIMM/DIMM) either it is DDR1 or DDR2 supporting and front system bus speed etc.
- 3 Find the RAM location on motherboard by referring quick guide or manual.
- 4 Note the number of RAM slots available on board.
- 5 Identify the master and slave RAM slots by printed information or by colour or reference manual.
- 6 Note each RAM slot maximum capacity.
- 7 Note the RAM slot information like type of RAM supporting and RAM Series (1, 2, 3 etc.).

**Some slots are supporting two or more series.**

### TASK 5: Replacing and Extending the RAM

- 1 Note the fixed RAM information available on board.
- 2 Observe the RAM lock tabs types available on slots.
- 3 Identify and note the reference notch point of slot.
- 4 Open the lock tabs gently.
- 5 Hold the RAM in the proper direction and matching reference notch as shown in Fig 1.
- 6 Fix the RAM by pressing gently.
- 7 Ensure the proper locking of tabs.

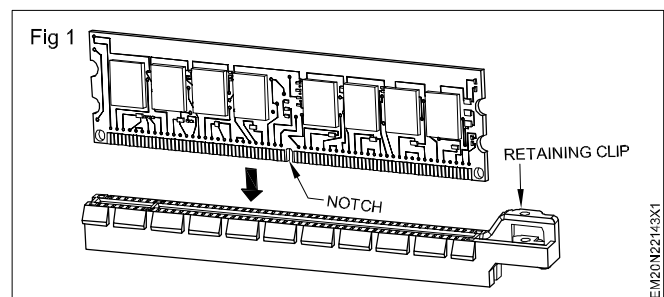

**Test and replace the SMPS**

**Objectives :** At the end of this exercise you shall be able to  
 • test and replace the SMPS from computer.

Requirements			
Tools/Equipments/Instruments		Materials	
• Trainees tool kit	- 1 Set.	• Complete assembly of Computer	- 1 No.
• Digital multimeter with probes	- 1 No.	• RC Solder	- 10 gm.
• Adjustable type Table Lamp	- 1 No.	• Paper clip	- 1 No.
• Magnifying Lens	- 1 No.	• A computer SMPS	- 1 No.
• Oscilloscope 0-20MHz Dual manual with probe kit and operation manual	- 1 No.		

**PROCEDURE**

**TASK 1 : Testing and Replacing the SMPS from computer**

**Switch Mode Power Supply (SMPS) alternating current (AC) convert into DC current into different output power supply. SMPS power supply to motherboard, Hard disk drive, DVD drive.**

**Please note, that there will be one green wire and many black wires. You can select any black wire you want.**

- Open the computer's casing. Be sure that the computer is completely turned off prior to starting.
- Remove the screws that are present in the side panel of the computer and need to remove only one side of the panel.
- Remove the connections from the SMPS to all the peripherals of the computer.
- Take a paper clip and bent it in a shape of 'U' shape.
- Find the 24 pin connector from your SMPS (obviously it is the bigger connector from SMPS). Try to locate green and black wire.
- Insert one end of the bent paper clip into the green terminal and the other end to the black terminal.
- Turn ON the SMPS with the wire inserted. The SMPS should be running now. If it does not turn ON, insert the paper clip firmly and try once more. If still the SMPS is turn ON, the SMPS might be faulty.
- If the PSU fan rotates you can 80 % confirm that the unit is functioning well.
- There are still chances that the PSU can be faulty which can be tested by checking the output volts at the pins.
- Reconnect the removed connectors and get the work checked by the Instructor.
- Get the work checked by the Instructor.

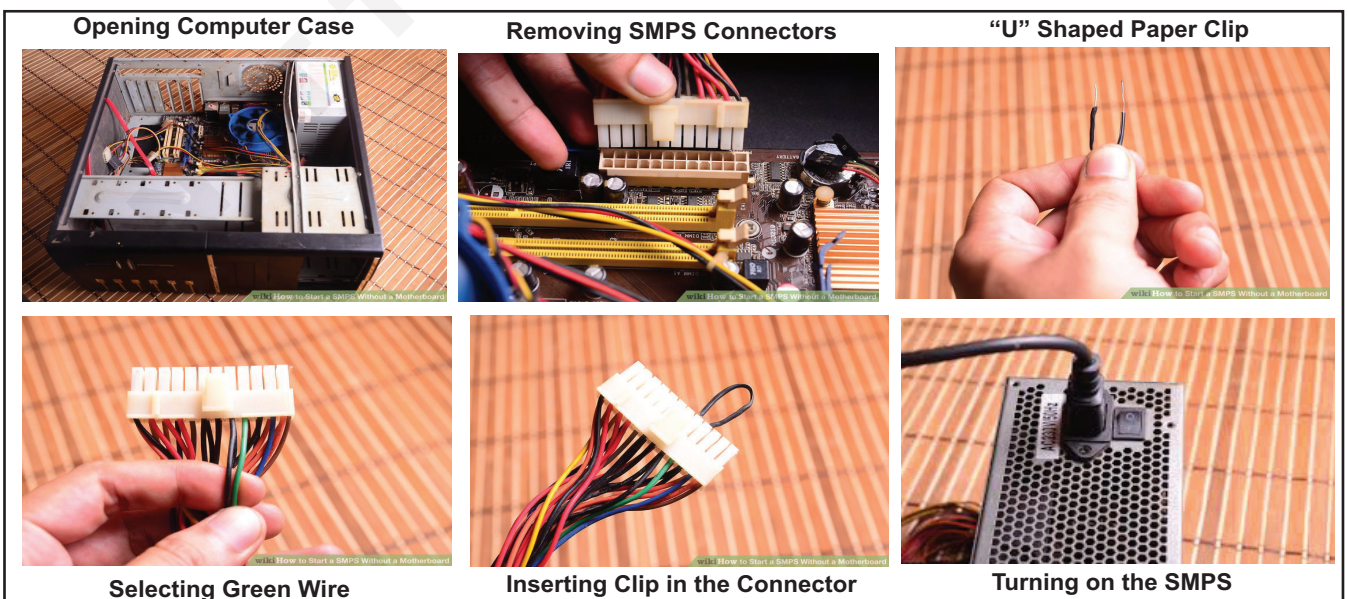

**Replace the given DVD and HDD on the system**

**Objectives :** At the end of this exercise you shall be able to

- to remove the CD/DVD and HDD from the drive cage
- to removal of the drives from the drive cage
- to assemble HDD into the computer.

<b>Requirements</b>			
<b>Tools/Equipments/Instruments</b>			
• PC with standard configuration	- 3 Nos.	• Screwdriver set and anti-static wrist strap	- as reqd.
• CD/DVD drives	- 2 Nos.	• Sticking labels (reusable)	- as reqd.
• HDD drives	- 2 Nos.	• Anti static covers	- as reqd.

**PROCEDURE**

**TASK 1 : Removing the CD/DVD and HDD from the drive cage system**

At the time of preparation of this exercise practice sheets, majority of the PC's have a single drive cage which hosts all drives. At the time of using this exercise, if situation is found to be different, the instructor in charge should suitably modify the procedure given below.

A Demonstrate the procedure for removing the drive cage consisting of at-least one HDD from the computer cabinet.

While demonstrating the following points should be considered;

- Identifying the mounting type and fixtures used.
- Use of correct tools and danger in case of using wrong tools.
- Technique involved in removing the front cover of the processing unit if found necessary.

- Identifying the snap on springs of drive cage
- Identify the drive cage guide in the cabinet
- Technique involved in pressing the snap on springs and taking out the drive cage.
- Precautions to be taken while handling the drive cage such that other components mounted inside the processing unit does not get damaged.

- 1 As demonstrated by the instructor, unscrew the fixing screws and remove the drive cage slowly & gently without causing damage both to the drives inside the drive cage and to other components/boards mounted inside the processing unit.
- 2 Get the removed drive cage checked by the instructor.

**TASK 2 : Removal of the drives from the drive cage**

**The instructor has to demonstrate the technique, tips and precautions to be taken while removing the drives from the drive cage. While demonstrating, make the trainees understand why a drive is positioned in that place and why not at a different place in the drive cage.**

- 1 As demonstrated by the instructor, remove all the drives taking sufficient care that the drives are not handled roughly, not dropped or damaged while removing.

- 2 In each of the drives removed from the drive cage, identify the connectors/ sockets/ jumpers/ switches found at its back/ rear side. Make a rough sketch the connectors / sockets/ jumpers/ switches and record the number of pins and jumpers/ switch settings.
- 3 Identify and record the specifications of the drives given on the drives.
- 4 Get the removed drives, identified connectors/ sockets/ jumpers/ switches and recorded specifications of the drives checked by the instructor.



### TASK 3 : Assembling of HDD into the computer

A Demonstrate the procedure and technique of assembling:

- HDD into the drive cage.
- Drive cage into the computer cabinet\chassis While demonstrating the following points should be highlighted:
- Handling the drive cage while fitting the drives
- Technique in fitting the drives for correct alignment with respect to front panel.
- Checking the stability and firmness of the assembly

1 As demonstrated by the instructor, reassemble the drives in the order instructed in the drive cage. During assembling do not forget to follow the precautions given by the instructor. Take the advice of the instructor.

2 Get the reassembled drives on the drive cage checked by instructor for its correctness and stability.

B Issue one additional Hard Disk Drive of such a physical size that it can be fitted in the drive cage along with the existing drives.

Since the intention of asking the trainees to fix the second HDD is only to make them practice the skill of mounting the device in the drive cage, and practice connecting the cable, the issued HDD's may even be a defective drive. However if the added HDD is a working one, then the trainees can be made to learn the skill of formatting the second drive, taking image of the other hard disk and such other very relevant tasks.

3 Record the specifications of the second drive to be fixed on the drive cage. As demonstrated by the instructor, fix the given second HDD with great care and patience in the drive cage. Make sure that sufficient space exist between the drives mounted on the drive cage.

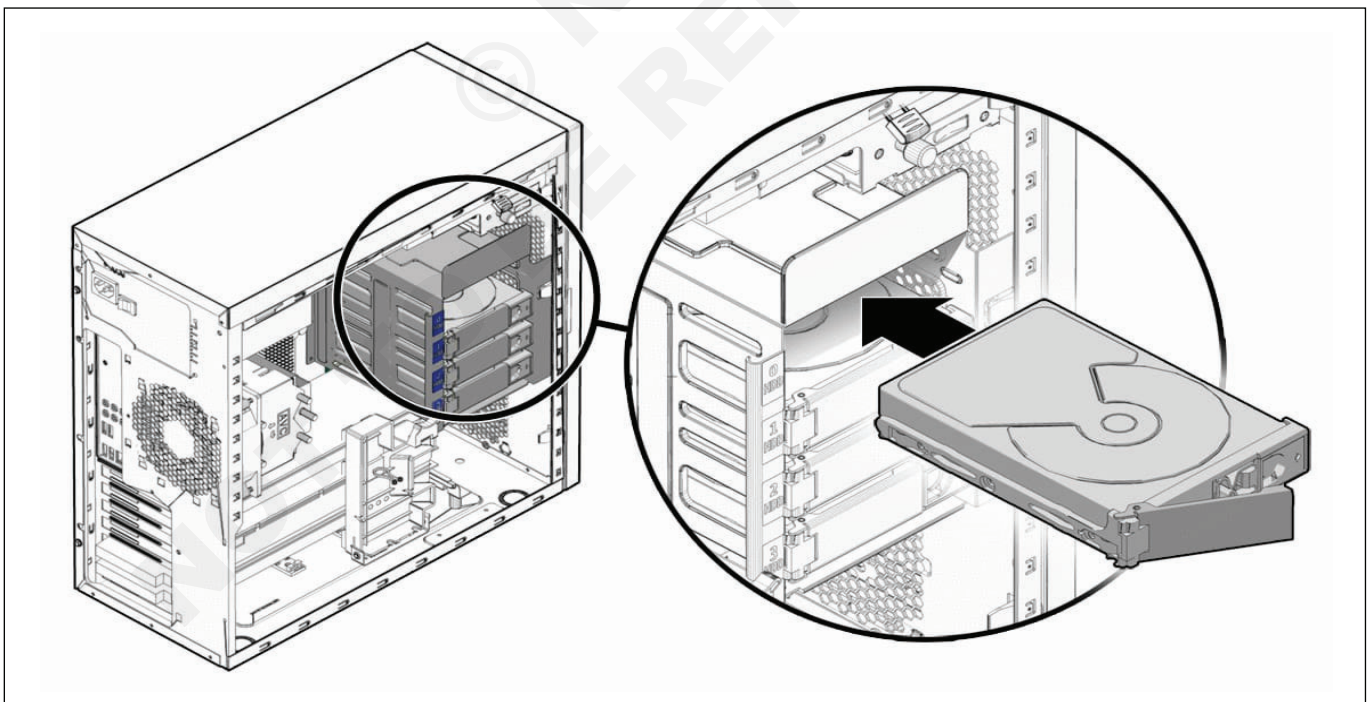
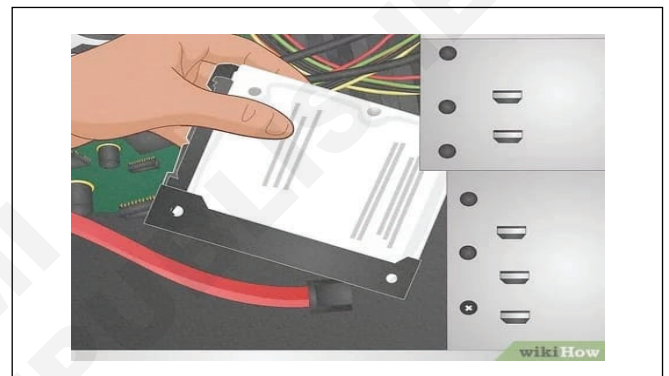

4 Get the work checked by the Instructor.

**Dismantle and assemble the desktop computer system**

**Objectives :** At the end of this exercise you shall be able to  
 • **dismantle and assemble desktop computer system.**

**Requirements**

**Tools/Equipments/Instruments**

- Identical PCs with labeled ports, connection cables (could even be dummy) - as reqd.
- I/O devices such as Keyboard, Mouse Monitor, Printer, Multimedia, Speaker, CD Drive, DVD Drive and Microphone - as reqd.
- Screw driver set and Allen key (depending upon the type of fixing used with connectors) - as reqd.
- Sticking labels - as reqd.

**PROCEDURE**

**TASK 1 : Assembling of desktop computer**

1 Prepare the Mainboard (motherboard). If you want to assemble you should use Intel i3,i5,i7,i9 processor supported Motherboard. (Fig 1)

Fig 1



2 Mount the CPU in the socket of the Motherboard. Be careful not to install the CPU in wrong direction, it could short-circuit and damage your motherboard. (Fig 2)

Fig 2



3 Connect the CPU cooler to the Mainboard if required use Thermal Paste. (Fig 3)

4 Attach the RAM (memory) modules in the corresponding slots. Make sure the pins on the RAM cards line up with the pins on the motherboard connector. (Fig 4)

Fig 3



Fig 4

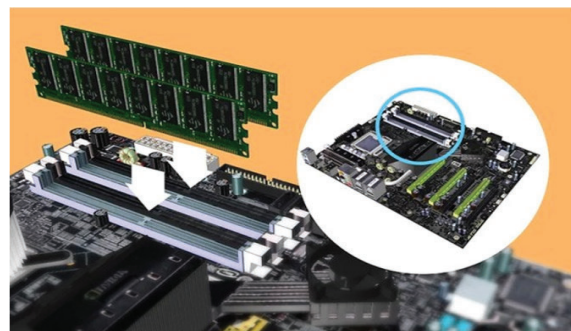

5 Open the Cabinet case and mount the power supply which is ATX type. Make sure to connect all the connections to the drives and the motherboard. (Fig 5)

6 Attach the Motherboard back plate to the case and check the Motherboard mounting positions. (Fig 6)

7 Suitably position the Motherboard in the cabinet. (Fig 7)

Fig 5

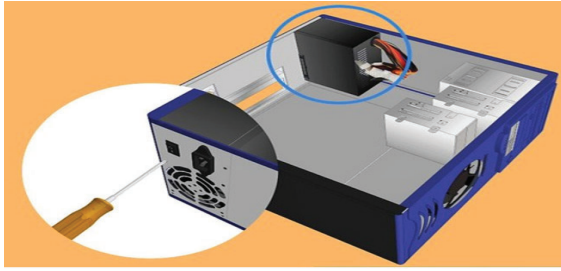

Fig 6

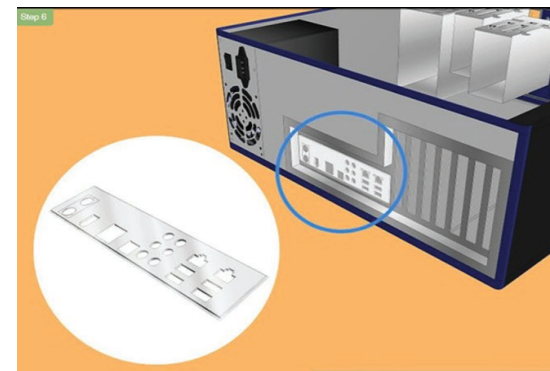
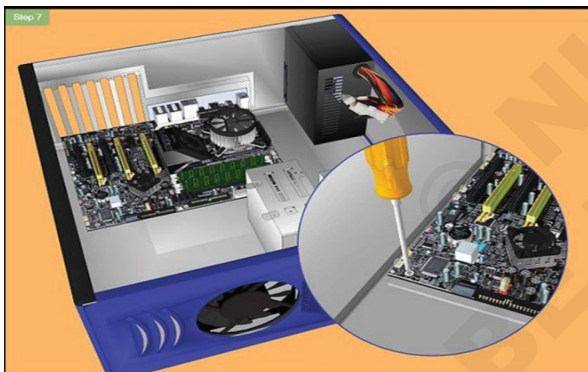

Fig 7



8 Mount the Hard disk and connect it to the power supply and the motherboard. There should be separate connections for the power supply, In SATA Hard disk case, should remove the jumper. (Fig 8)

Fig 8



9 Connect the SATA connectors to the drives and the USB connectors and the Cabinet Front Panel Power switches to the motherboard. The case and motherboard's instructions should tell where to connect the cables. (Fig 9)

Fig 9

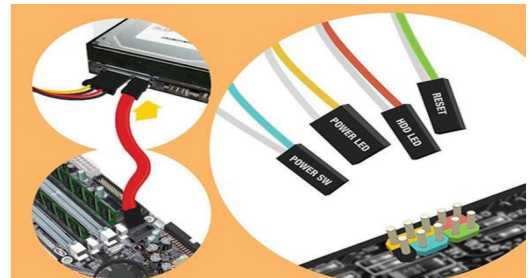

10 Connect the 24 pin ATX connector and the 4-pin power supply control connector to the motherboard. (Fig 10)

Fig 10



11 Mount the DVD-ROM drive. After connecting the SATA cable to the device, hook it up to the power supply. (Fig 11)

Fig 11



12 Finally, select a compatible operating system, and install using DVD or USB then follow the instructions to install. (Fig 12)

Fig 12



## TASK 2 : Disassemble of desktop computer

### 1 Disconnect all front panel connections (Fig 1)

Fig 1

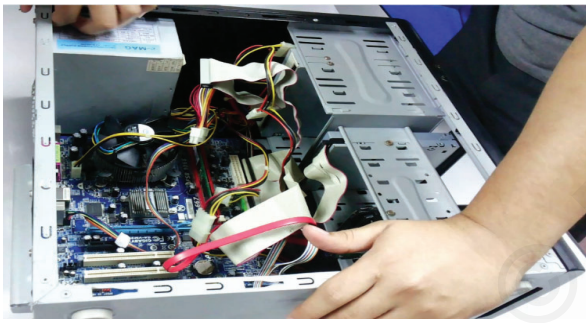

- Remove the power switch connector.
- Remove the speaker connector.
- Remove the power LED connector
- Remove the hard drive LED connector
- Remove the reset switch connector.

### 2 Disconnect the power supply connections (Fig 2)

Fig 2

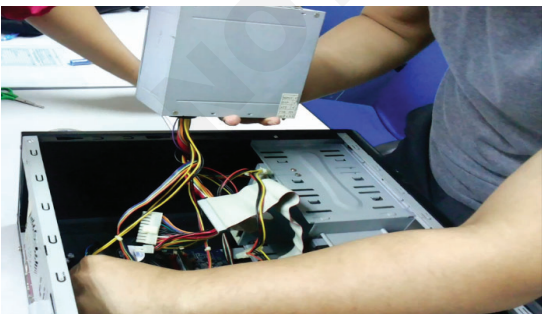

- Disconnect the power connector from the hard-drive
- Disconnect the power connector from the CD-ROM

- Disconnect the power connector from the floppy drive
- Disconnect the power connector from the tape drive
- Disconnect the power connectors from the system board

### 3 Remove the power supply (Fig 3)

Fig 3

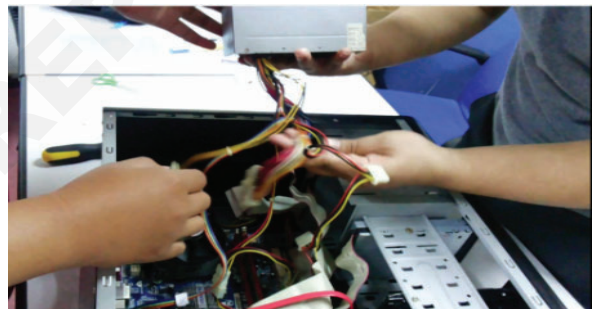

- Remove the switch mounting screw from the switch mount at the front of the chassis.
- Remove the four screws from the back of the chassis that hold the power supply onto the chassis.
- Remove the power supply.

### 4 Disconnect all internal ribbon cables (Fig 4)

Fig 4



- Disconnect the IDE ribbon cable from the hard-drive.
- Disconnect the IDE ribbon cable from the CD-ROM.
- Disconnect the IDE ribbon cable(s) from the system board.
- Disconnect the FDD ribbon cable from the floppy disk drive
- Disconnect the FDD ribbon cable from the system board.
- Remove all the ribbon cables from the computer.

#### 5 Remove the drives from the chassis (Fig 5)

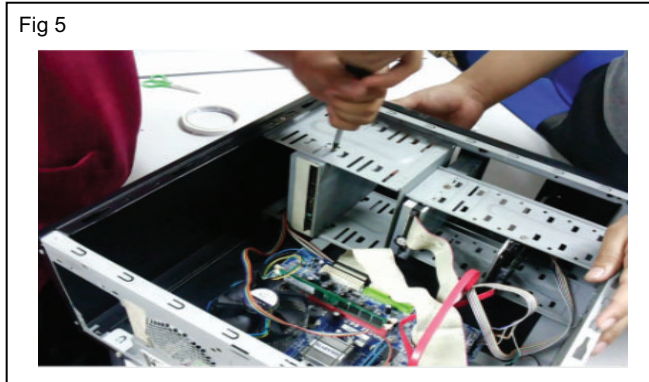

- Remove the CD-ROM drive (Fig 6)



- Remove the floppy drive (Fig 7)

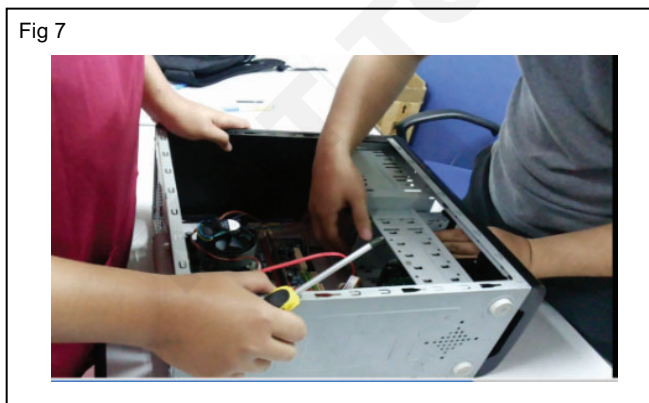

- Remove the hard-drive
- #### 6 Remove the system board mount and the system board (Fig 8)
- Remove the screws from the system board mount
  - Pull the system board mount and the system board from the chassis

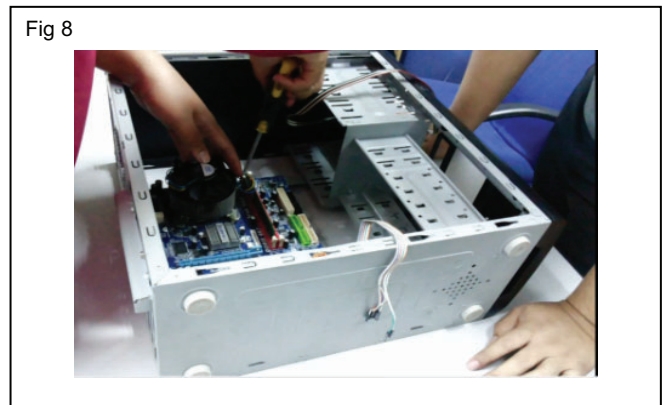

- Remove the system board mounting screws from the system board
- Remove the system board

#### 7 Identify the adapter cards (Fig 9)

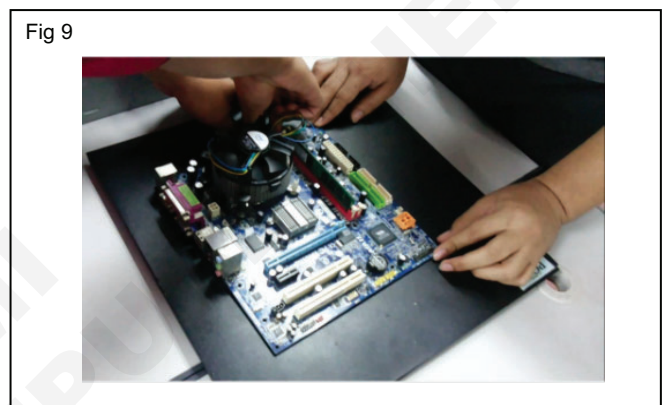

- Identify the video card. It is the one that the monitor is (was) plugged into.
- Identify the serial port mount. It is the one with a D25-pin male port and a D9-pin male port.
- Identify the parallel port mount. It is the one with D25-pin female port.

#### 8 Remove the adapter cards (Fig 10)

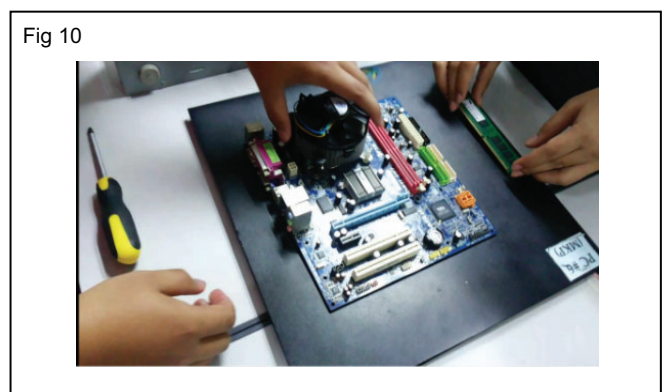

- Unscrew the video card from the back panel and then remove it and place it into an anti-static bag.
- Unscrew the serial mount from the back panel and then remove the ribbon cables from the system board.
- Repeat step above to the parallel mount.
- Unscrew any other adapter cards that might be installed in this PC and remove them from the PC.

**Boot the system from different options**

**Objectives :** At the end of this exercise you shall be able to

- boot the system using Windows operating system
- shut down the computer
- change the booting order from HDD to CDROM Drive in BIOS.

<b>Requirement</b>	
<b>Tools/Equipments/Instruments</b>	
• Desktop PC	- 1 No.

**PROCEDURE**

**TASK 1 : Booting the system using Windows operating system**

- 1 Prepare your bootable DVD or USB disk with Windows 10 ISO Image.
- 2 Keep your DVD or USB as First Boot Device in Boot Order Option of BIOS Setup.
- 3 Press F1 / F2 / F10 / Delete or Del / Esc to enter BIOS Setup into your computer when its powered ON and Display POST Code messages along with Manufacture logo.

**Note: BIOS setup Entry option may very based on Computers manufactured, refer Manual.**

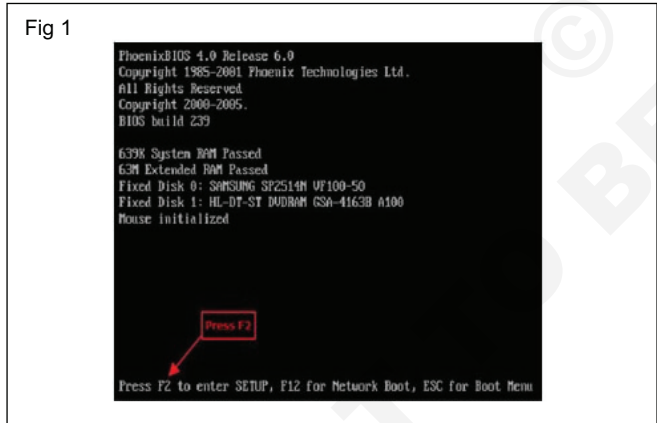

- 4 After enter into BIOS Setup Utility Choose Boot Option ' Boot Device Priority Setting
- 5 Select Removable Device for USB or CD Rom Drive for Optical Drives
- 6 Ensure Boot Mode option into UEFI / Legacy, Windows10 Recommended UEFI.

**Note:**

- **Legacy Boot is the boot process used by BIOS firmware, Its uses Valid Master Boot Record (MBR).**
- **UEFI boot is the boot process used by UEFI firmware, Its uses valid GUID Partition Table (GPT)**

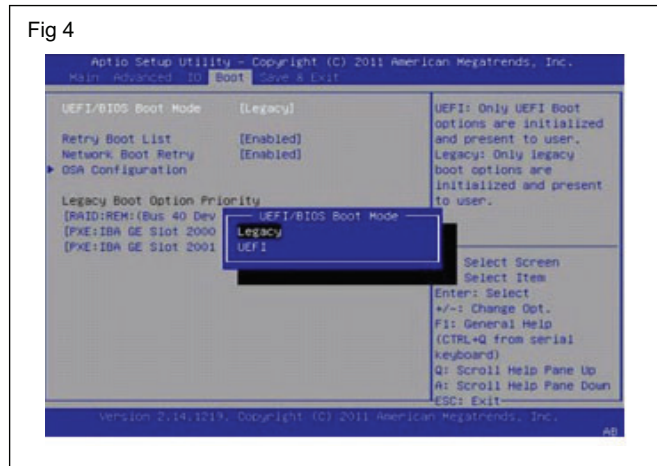
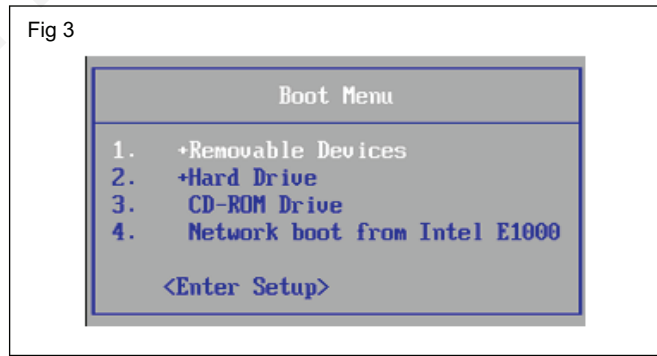
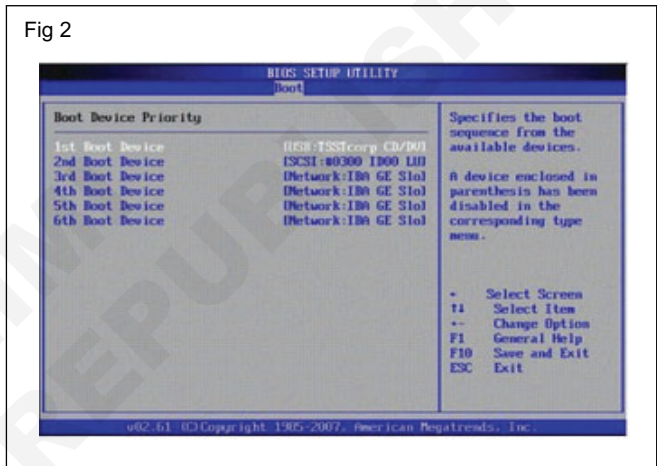

7 F10 to Save BIOS setup configuration and Exit.

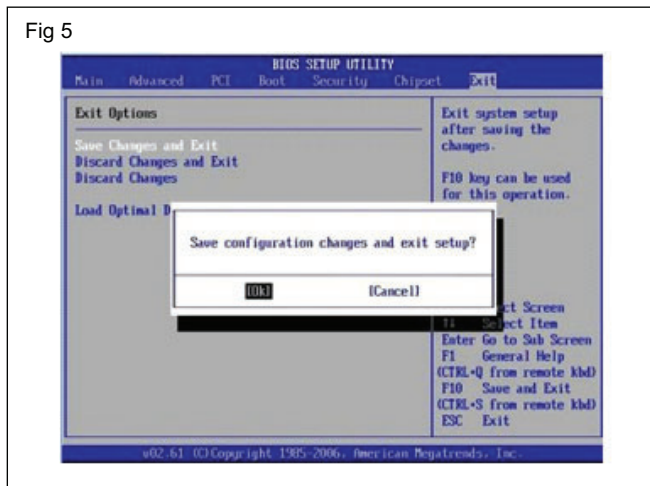

8 Insert the Image DVD into optical Drive and reboot the PC then Press any key to boot the Installation from DVD.

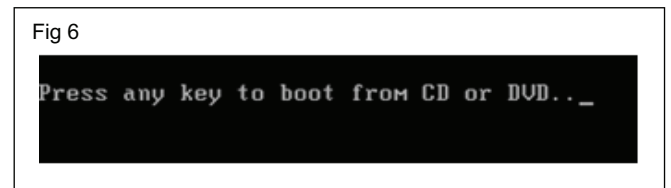

9 Or Insert the USB Flash Drive into USB Port and reboot the PC.

**TASK 2 : Shutting down the computer**

- 1 Close all the open programs.
- 2 Click 'ON' the start menu button and select shut down Option.
- 3 Move the Cursor over option dialog box and select "shut down " option and click "Ok" button.

**This makes the Windows to close all opened / running applications if any and shuts down all activity on the computer so that the power to computer can be turned off.**

- 4 Wait till screen goes blank.

**Although the windows OS closes all running application and then shuts down the PC , it is**

**not recommended to keep any application open at the time of turn off the PC.**

- 5 Switch 'OFF' the supply in the following sequence.
  - External peripheral devices such as printer, Monitor, Speaker, etc.
  - CPU System
  - Power 'OFF' the Distribution box
  - Stabilizer/CVT/UPS unit
  - AC mains
- 6 Get the work checked by the Instructor.

**TASK 3 : Changing of the booting order from HDD to CDROM Drive in BIOS**

- 1 First start the computer and during the initial booting process display the message.
- 2 Press Del or 'F2' key on the keyboard to enter into CMOS BIOS setup . The BIOS Setup screen display the startup screen.

**Entering into CMOS setup by pressing DEL key is not suitable for all PC. The step for Entering into the CMOS setup depends on the motherboard. Press the correct keyboard command for entering into setup display on your computer.**

- 3 Select Boot Menu option by moving the arrow keys on the keyboard and press enter key.
  - Boot option menu display the options.
- 4 Select removable device option from boot order.

**BIOS will first try to boot from any removable devices - like floppy drives or flash drives. If no removable devices are bootable, BIOS will next try the hard drive, followed by the CD-ROM drive, and finally the network.**

- Boot order can be changed by pressing the '+' and '-' keys.
- 5 Set CD ROM drive as a first Boot device and Removable device as a second boot device and hard drive as a third boot devices.
- 6 Move the arrow key to "Exit" menu and select Exit saving changes option ( or Press F10 key on the keyboard) will display on the screen.
  - Setup will display the confirmation message on the screen.
- 7 Select "Yes" by moving arrow key and press ENTER key on the keyboard for save your CMOS. Configuration changes and exit form setup.
  - Now the computer will restart automatically and ready to boot from CD ROM drive by display a message for your confirmation.
- 8 Press any key to accept boot from CD ROM drive..
  - System loads OS from CD ROM drive and starts working.
- 9 Get the work checked by the instructor.

**Install OS in a desktop computer**

**Objectives :** At the end of this exercise you shall be able to

- install windows OS on the PC
- format a secondary hard drive
- install driver software from motherboard CD.

Requirements			
<b>Tools/Equipments/Instruments</b>			
• A working PC	- 1 No.	• Operating system CD	- 1 No.

**PROCEDURE**

**TASK 1 : Installation of windows OS on the PC**

Enter into CMOS setup

- 1 Power on PC.

**Prompt message is displayed as follows  
Press <DEL> to enter setup**

- 2 Press <DEL> key

**Immediately enter into CMOS setup utility menu.**

- 3 Insert the windows 10 installation disk into CD Rom drive.

**The PC will now restart and see a message at the top of the screen telling to "Press any key to boot from CD " as shown in Fig 1**

- 4 Go ahead and Press any key for setup to begin

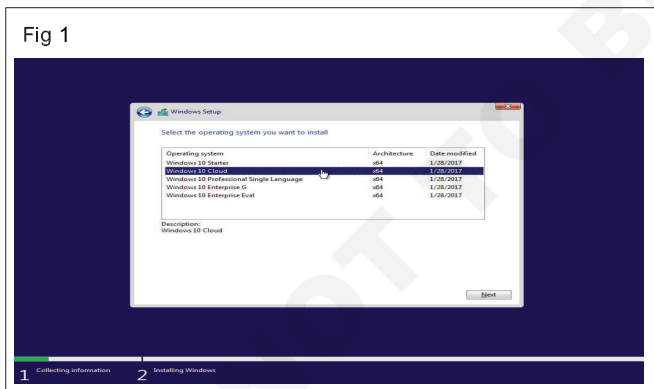

**Installation of OS will format hard disk. Format will delete all the information stored in the hard disk. Copy all the important documents before start setup.**

- Once setup begins a message stating that setup is inspecting computer's hardware Configuration.
- Then windows will copy files and continue to start setup.

**Next the setup welcome screen appear.  
Press Key "R" for repair the existing corrupted Windows OS. If you to stop installation press F3 key.**

- 5 Press "ENTER" Key to continue windows setup process.

**Next EULA screen appear on the screen**

- 6 Press F8 to accept the Windows 10 Licensing Agreement.

**If an existing Windows 10 installation is detected, are prompted to repair it. To bypass the repair, press "ENTER" Key.**

Partition the disk

**All existing partitions and non-partitioned spaces are listed for each physical hard disk.**

**If you want to create a partition where one or more partitions already exist, first delete the existing partition or partitions, and then create the new partition. You can move the arrow keys to select an existing partition press D to delete, and then press L (or press ENTER, and then press L if it is the System partition) to confirm that you want to delete the partition. Repeat this step for each existing partition that want to include in the new partition. When all the partitions are deleted, select the remaining non-partitioned space, and then press C to create the new partition.**

- 7 Use the ARROW keys to select an existing partition, or create a new partition by selecting the non-partitioned space



**When want to create a new partition can also press C to create a new partition using non-partitioned space.**

**If your hard disk is new one then need to do a partition and format your hard disk.**

8 Press "Enter" key to create the partition.

**To specify the partition size, type the size in megabytes (MB) for the new partition.**

9 Repeat steps 8 to 9 to create additional partition.

**OS starts partitioning the total hard disk memory space into 2 or 3 partition as allotted.**

10 Press the Arrow keys to select the partition where you want to install Windows XP, and then press ENTER.

**The next screen to choose the file system to reformat hard drive.**

11 Select the format option by moving the arrow keys and press "ENTER":

**Format process will come on the screen.**

**Setup program will now format the partition drive and copy the files followed by a restart.**

**Do not press any key to boot at this point**

**Next screen showing that your computer will restart in 1 minutes.**

**Computer restart with windows 10 screen.**

12 Setup will now ask to select language

13 Move the cursor to US and English click "Next " Tab  
Enter your name and organization appear on the screen.

14 Select "Next" tab to continue installation.

15 Type product ID code on the next screen.

**Product ID code is available on the side of the computer Tower or CD cover.**

16 Enter Name of the computer , Administrator password and confirm the password by retyping the password again asked in the next screen.

**If not interested to give password then just press "Enter" key to skip the Step.**

17 Click "Next " Tab to go to Time zone screen.

18 Set month, date, time and Click "Next" tab.

**Wait for the Next Network settings screen appear on the screen.**

19 Click "Next" tab to finish installation.

**Computer restart with Windows 10 OS followed by Desktop screen.**

**Install a printer driver software and test for printouts**

**Objectives :** At the end of this exercise you shall be able to

- add local printer in windows 10 operating system
- install a wireless printer
- performing self test on printer.

<b>Requirements</b>			
<b>Tools/Equipments/Instruments</b>			
• PC with windows 10 OS	- 1 No.	• Printer, scanner, web camera & DVD drive software	- 1 No.

**PROCEDURE**

**TASK 1: Add local printer in windows 10 operating system**

**The most common way to connect a printer to the PC is by USB cable, which makes it a local printer. And also install a wireless printer or add a printer connected to another computer on your network which makes it a Network Printer.**

- 1 Connect the printer to your computer using the USB cable and turn it on.
- 2 Open the Settings app from the Start menu.
- 3 Click Devices as shown in Fig 1.

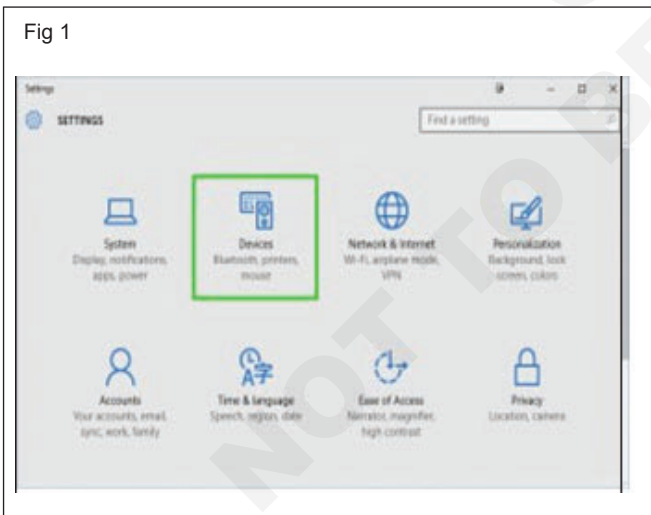

- 4 Click Add a printer or scanner as on Fig 2.
- 5 If Windows cannot detect the connected printer, click the printer that I want isn't listed link as shown in Fig 3
- 6 On the Find a printer with other options window, click to select the Add a local printer or network printer with manual settings radio button.

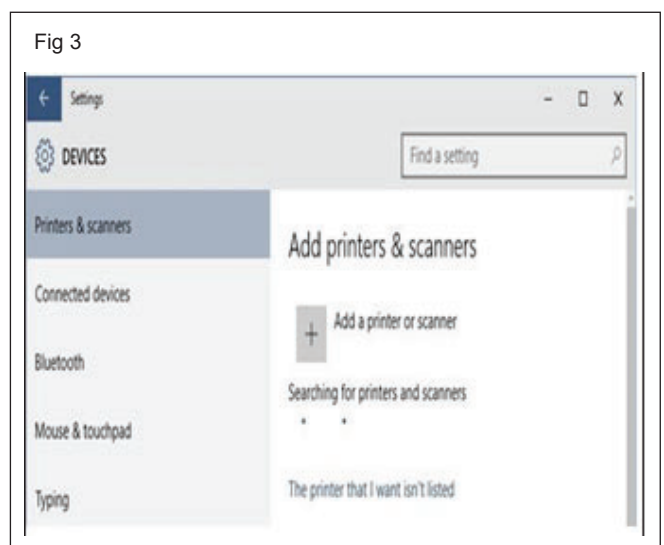
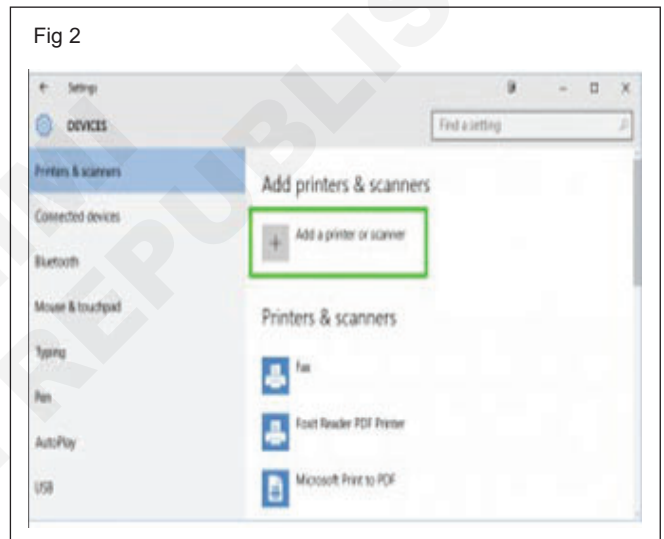

7 Click Next to continue as on Fig 4.

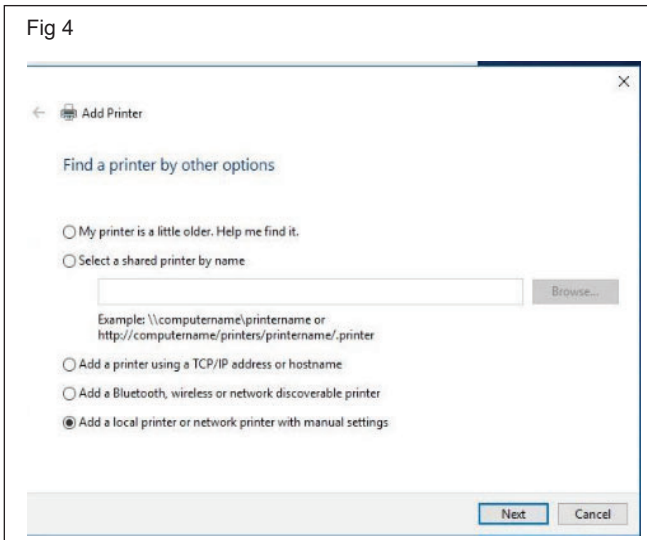

8 On the Choose a printer port window, leave the default options selected and click Next.

**If you are an advanced user, you can also choose a different option from the Use an existing port drop-down list, or you can define your own port by selecting the Create a new port radio button and specifying your custom port in the enabled field as on Fig 5.**

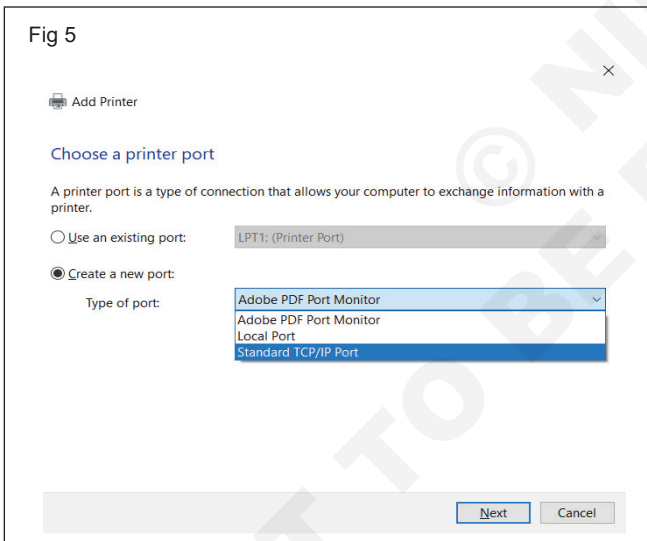

9 click Next.

10 On the Install the printer driver window, from the displayed list of printer manufacturers in the left section, click to select the one to which the connected printer belongs.

11 From the right section, locate and click to select the specific model of the printer that is connected to the PC.

**Note: At this point, you can also click the Have Disk button and browse and locate the driver for the connected printer if you have downloaded it manually from its official website or driver DVD linked by manufacturer.**

12 Click Next to proceed to the next step as on Fig 6.

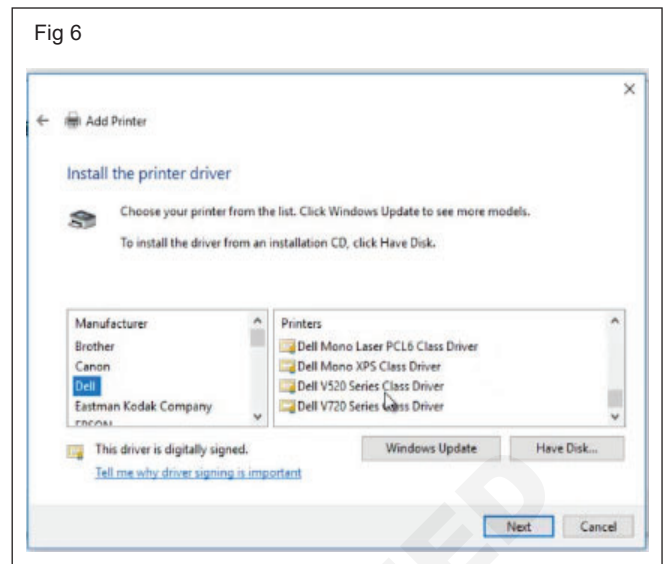

13 Type a printer name window, in the Printer name field, type an informative name for the printer as shown in Fig 7.

14 Click Next.

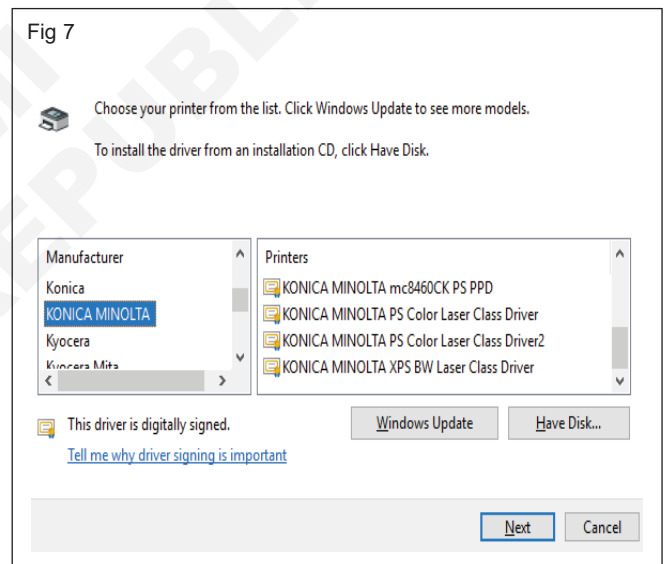

15 If you share the printer, select "Share this printer so that others on the network can find and use it" radio button.

**Note: If you do not want to share the printer with the network users, you can select the Do not share this printer radio button.**

16 In the Share name field, type a short share name for the printer.

**Note: The name you specify here will be displayed to the remote users when they search for this printer over the network.**

17 Populate the Location and Comment fields with your preferred information.

18 Click Next to continue as on Fig 8.

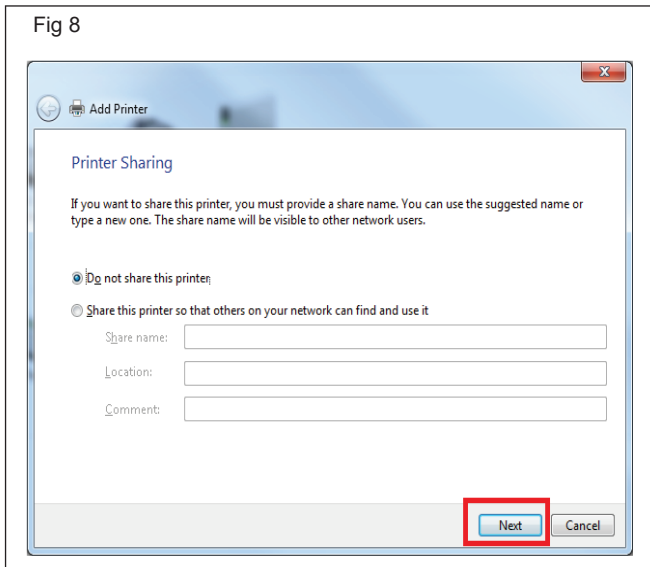

19 On the final page of the wizard, click the Print a test page button to check the connectivity and proper functioning of the printer.

20 Click Finish to complete the process.

## TASK 2: Installing a wireless printer

- 1 Open Settings.
- 2 Click on Devices.
- 3 Click on Printers & scanners.
- 4 Click on the Add a printer or scanner button as on Fig 1.

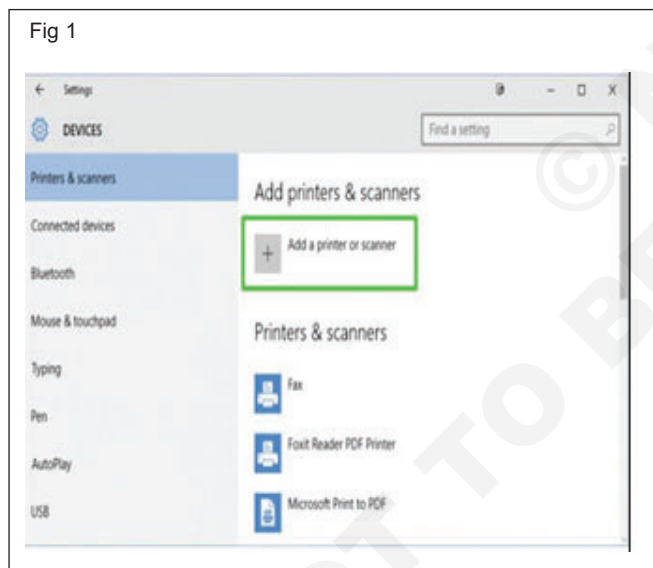

- 5 Select the printer from the list and click Add device to install the wireless printer to Windows 10 as shown in Fig 2.

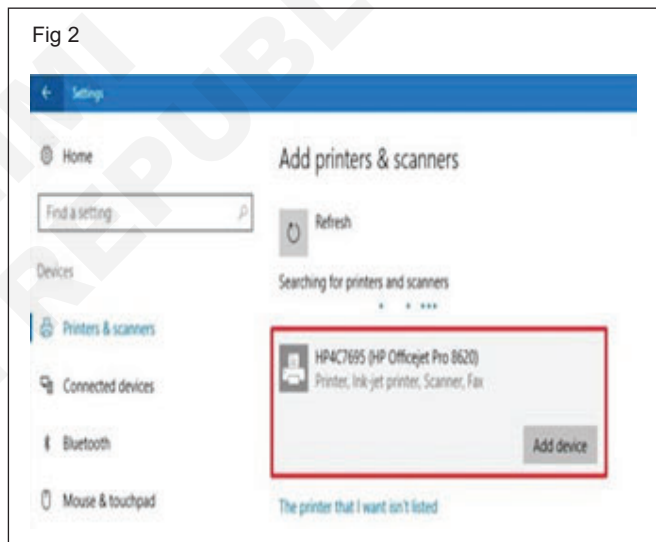

## TASK 3 : Performing a Self - Test on Printer

- 1 Turn on your computer and printer.
- 2 Click" start" on your Windows taskbar.
- 3 Choose "Control Panel" then
 

Printers and Faxes
- 4 Click" View Installed Printers".
- 5 Right click on the installed printer icon.

- 6 Click "Print Test Page" to start the self-test.

**Perform a self-test each time you install a new ink cartridge, or when your print quality is low.**

**The self-test will not work well if the printer ink levels are low.**

**Install antivirus software, scan the system and explore the options in the antivirus software**

**Objectives :** At the end of this exercise you shall be able to

- install antivirus software from a disc
- install antivirus software from internet
- scan the system for virus.

<b>Requirement</b>	
<b>Tools/Equipments/Instruments</b>	
• Computer or Laptop with Windows operating system	- 1 No.
• CD of antivirus software	- 1 No.

**PROCEDURE**

**TASK 1 : Installation of antivirus software from a Disc**

1 Load the anti-virus CD-ROM into the disc tray and close, then wait for the CD menu to appear on screen.

After you click the "Install Now" button, the required files will automatically download to the computer.

Step 1: Click the "Install Now" button

2 Type in the product security code in the boxes on the screen.

This should be located in the lower left hand corner of the web site. Clicking this button begins the process.

**The security code is printed on the back of the plastic case for the CD-ROM containing the anti-virus software.**

Step 2: Download the required files

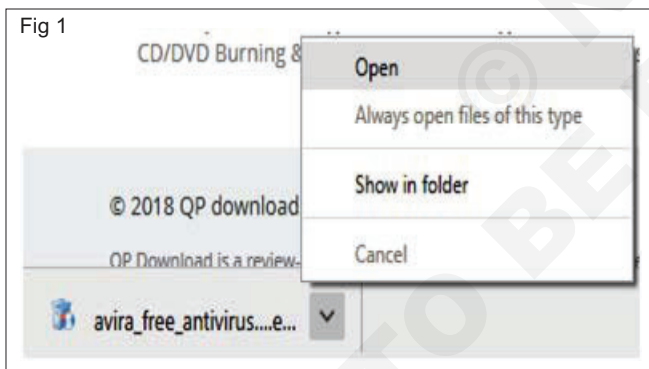

3 Follow the on-screen prompts, clicking "Yes" when asked, "Do you wish to install this software?"

4 Reboot the computer when the installation is complete.

This involves shutting down and restarting the computer so the anti-virus settings can take effect.

5 Get the work checked by the Instructor.

**TASK 2 : Installation of Antivirus Software From the Internet**

1 Go to an anti-virus software company site on the Internet to purchase an anti - virus program.

Some offer trial versions of anti-virus programs for free.

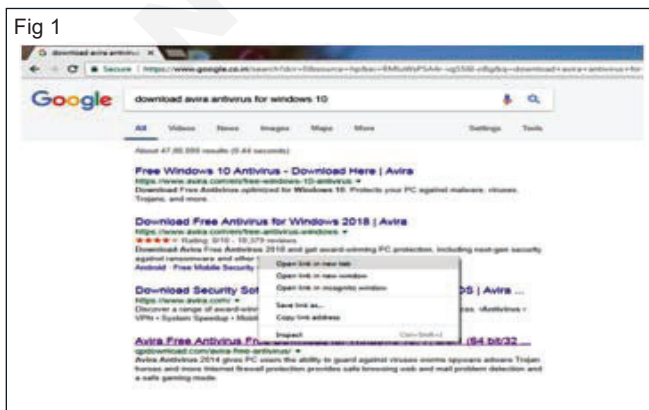

2 Choose the software product, wish to purchase from the company's menu of offerings and click "Buy Now" or "Download Now".

3 Enter the credit and other personal information in the required fields to purchase the software, then press "Enter".

4 Follow the on-screen prompts, clicking "Yes" when asked if wish to download the software to the computer.

5 Wait for the download to complete.

**This could take several minutes, depending on the speed of the Internet connection. Do not log off the computer or change any setting until the software has finished downloading to the system.**

6 Reboot the computer if prompted at the end of the download.

7 Get the work checked by the Instructor.

Fig 2

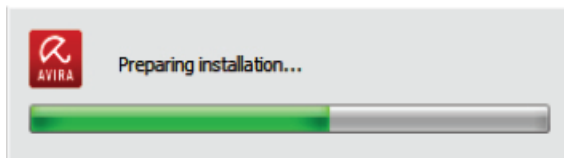
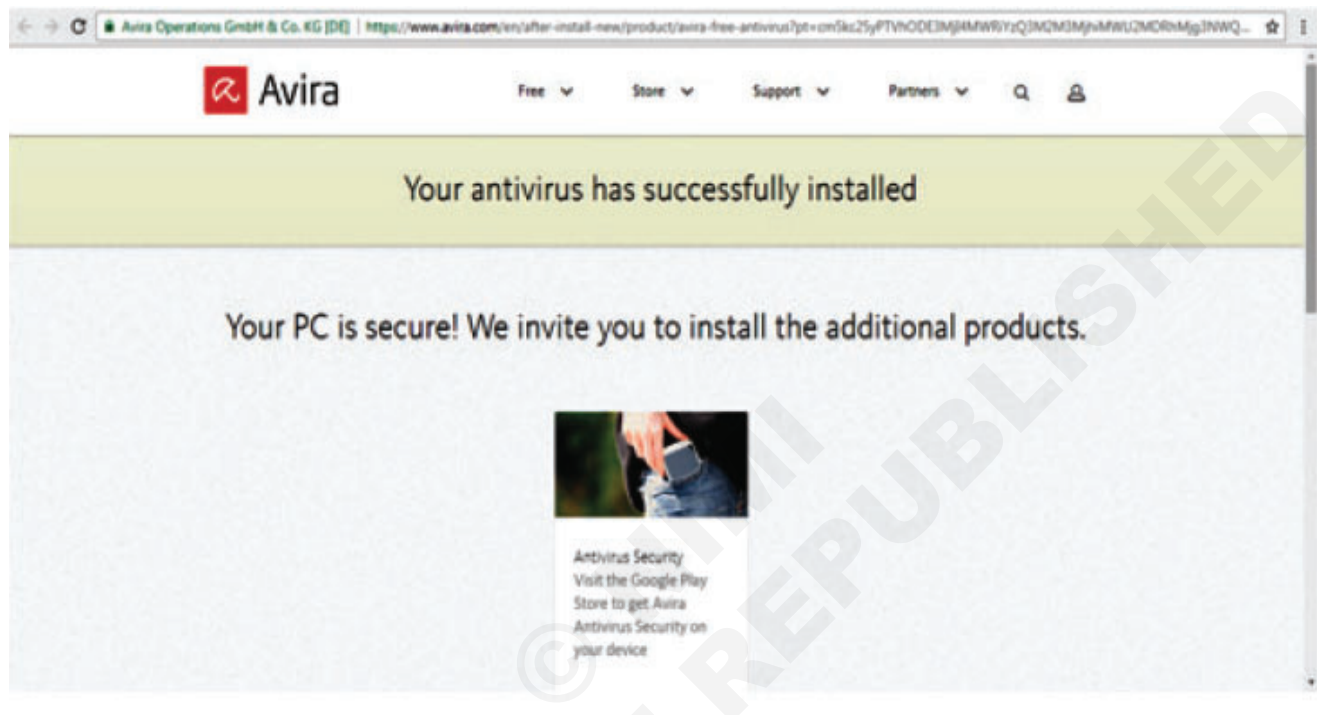

Fig 3



-----

### TASK 3: Scanning the system for virus

- 1 Go and select the anti-virus software from the start menu.
- 2 Find the system SCAN button on software screen
- 3 Click the button for scan

- 4 Observe and study the status report of software
  - 5 Observe the virus and warning shown by the software.
  - 6 Get the work checked by the Instructor.
-

Install MS Office software

**Objectives :** At the end of this exercise you shall be able to  
 • install the MS Office software in the Personal Computer.

Requirement			
<b>Tools/Equipments/Instruments</b>		<b>Materials/Components</b>	
• Trainees tool kit	- 1 Set.	• Microsoft Office-2010 Enterprises CD	- 1 No.
• Personal Computer	- 1 No.		

PROCEDURE

TASK 1 : installation the MS Office software in the Personal Computer

- 1 Before you do anything else, make sure that no program is running. Otherwise, it might cause some malfunctions and cause damage to your computer. Insert the DVD in the DVD-ROM. Wait for a new window to appear. You can even click on the executable file for Office by browsing to CD in My computer and run the program.
- 2 Wait for the installation window to appear. When the next windows appear, click on install after selecting Microsoft Office 2010.
- 3 Select the features you want to install from the installation options tab. Then select the drive
- 4 Enter the product key. This consist of 25 characters. You may have to click continue.
- 5 Then a window will appear with agreement terms. Please read and accept the agreement terms.
- 6 On the window that appears next choose Upgrade to Install or Custom (if you want modified settings). If you already have Office installed you may want to upgrade or customize, otherwise click install.
- 7 Your programme will automatically install once you click on Upgrade. This may take a few minutes.
- 8 If you chose Custom, modify your settings by clicking on Configure preferences.
- 9 The installation will start and a bar will appear. Wait for it to go upto 100 then proceed.
- 10 Click on close and run Microsoft Office from the Programs in the Start Menu.

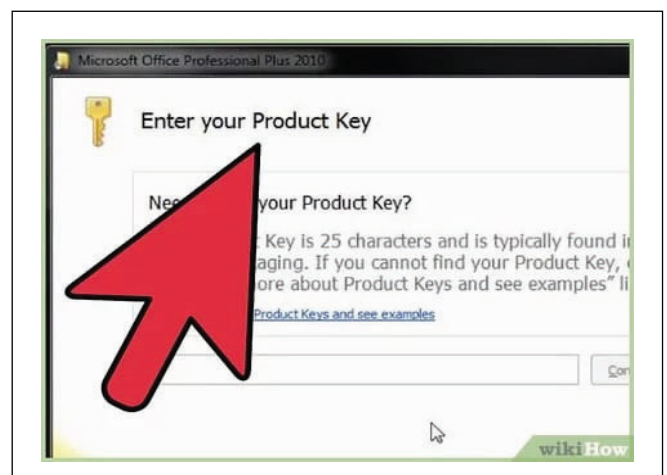
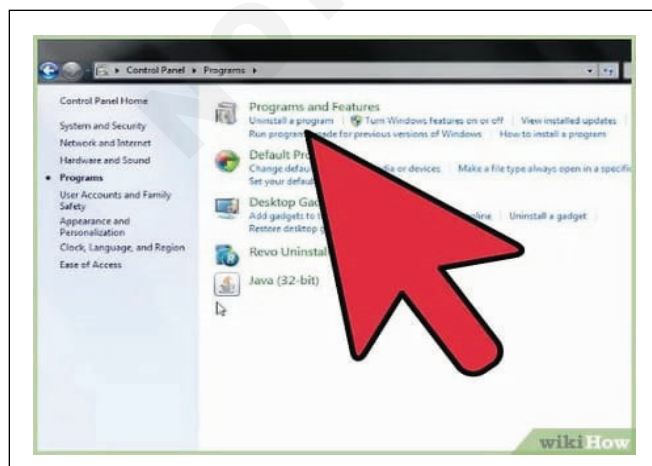
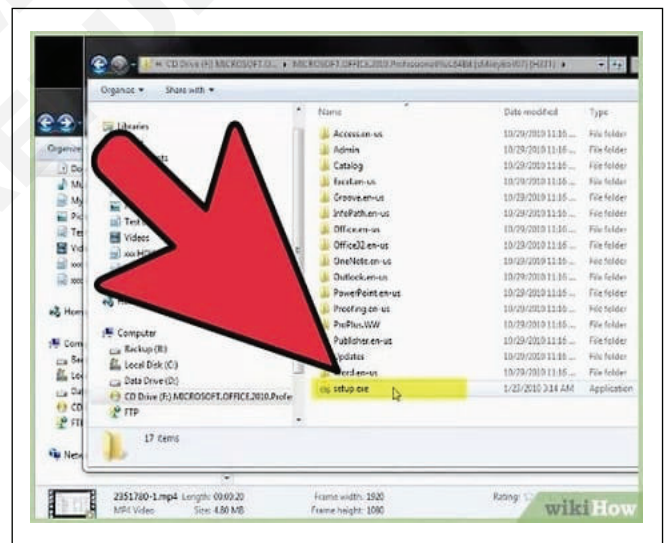

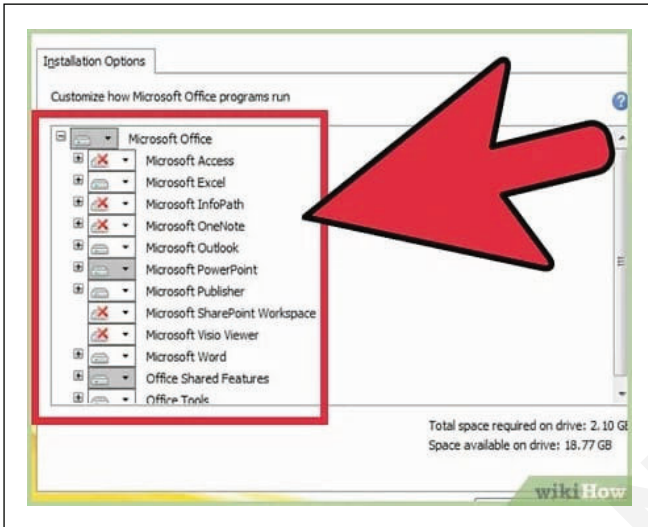
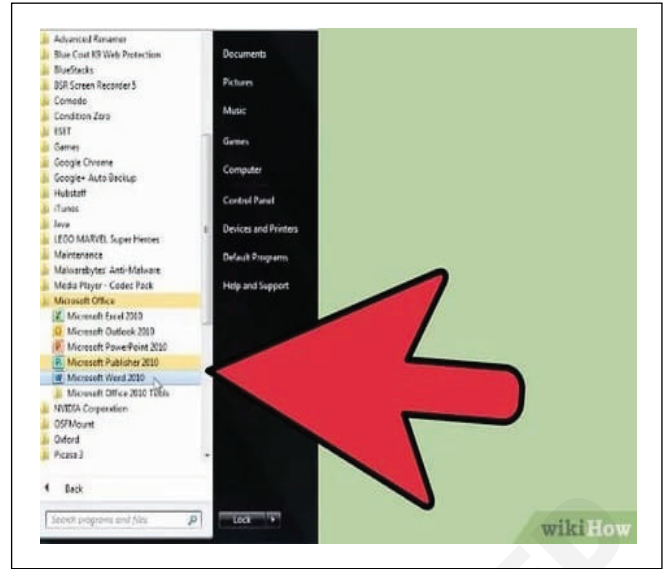
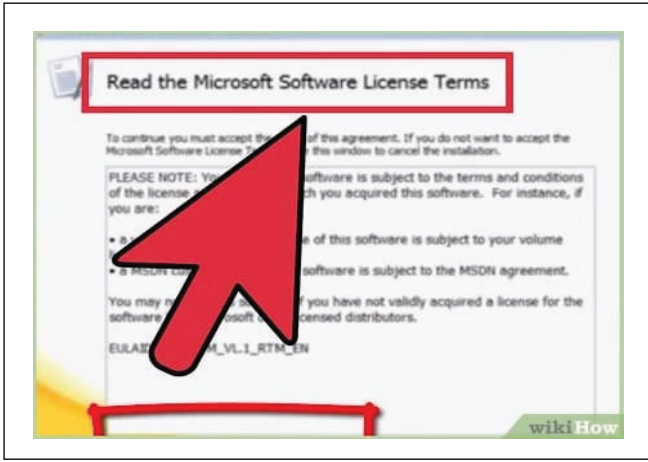



**Browse search engines, create email accounts, practice sending and receiving of mails and configuration of email clients**

**Objectives:** At the end of this exercise you shall be able to

- open yahoo website, google website, dictionary website
- download images, software
- create, open the mail account and compose mail
- check the inbox
- checking, entering, replying the new mail account in Yahoo site
- creating, renaming, deleting, moving the new folder.

Requirement	
<b>Tools/Equipments/Instruments</b>	
• Desktop Computer or Laptop with windows OS	- 1 No.
• Internet Connection	- 1 No.

**PROCEDURE**

**TASK 1 : Opening the Yahoo Website**

- 1 Boot the system, if not booted.
- 2 Check the internet connection.
- 3 Double click the internet explorer on the desktop or
- 4 Choose Start button as in Fig 1.

- 5 Select Programs as in Fig 2.

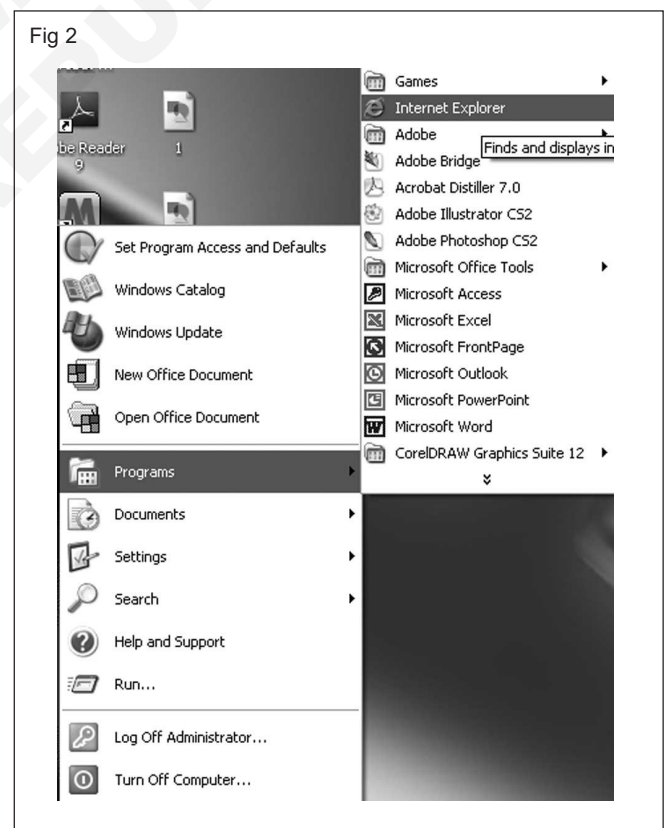

- 6 Click Internet Explorer
- 7 Opened internet explorer window
- 8 Type the website address : [www.yahoo.com](http://www.yahoo.com) on address bar as in Fig 3.
- 9 Displayed yahoo web site.
- 10 Get the work checked by the Instructor.



**TASK 2 : Opening the Google**

- 1 Type the address : [www.google.com](http://www.google.com) on address bar as in Fig 1
- 2 Displayed google website.
- 3 Get the work checked by the Instructor.

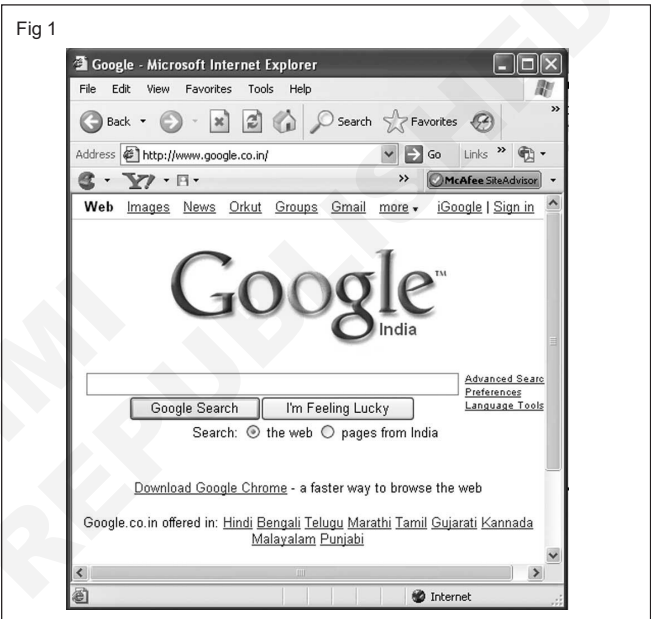

**TASK 3 : Opening Dictionary.com website**

- 1 Type the address : [www.dictionary.com](http://www.dictionary.com) on address bar as in Fig 1
- 2 Displayed dictionary website.
- 3 Get the work checked by the Instructor.

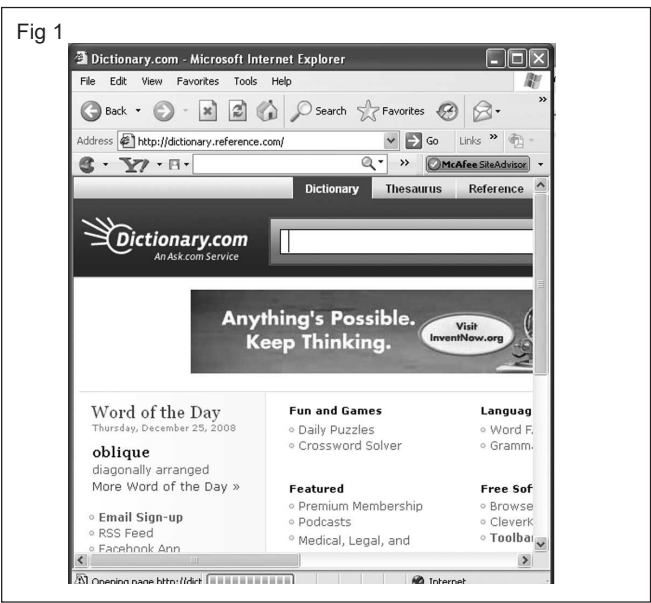

#### TASK 4 : Downloading a Picture

- 1 Type the address : [www.google.com](http://www.google.com) on address bar as in Fig1.
- 2 Type the word "Flowers" on text box.

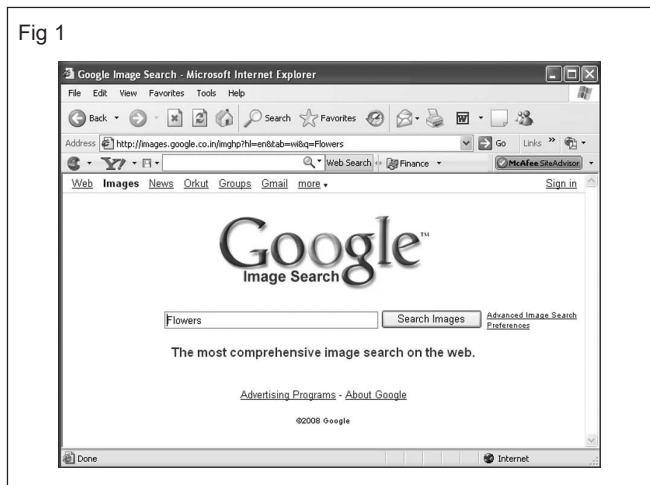

- 3 Click Images tab.
- 4 Click Search image button.
- 5 More flower images are displayed.
- 6 Click any one image.
- 7 Opened the flower image.
- 8 Select the flower image and right click the mouse button.
- 9 Click Save Picture as in Fig 2.

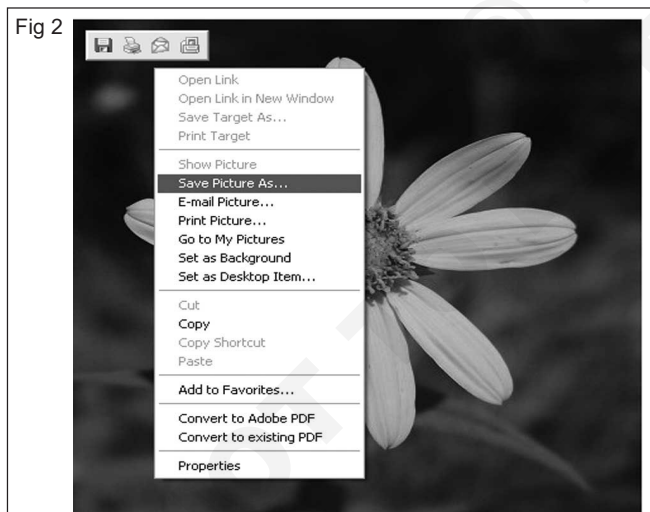

- 10 Choose saving location
- 11 Click Save button

#### Download Child Image

- 12 Type the address [www.yahoo.com](http://www.yahoo.com) on internet explorer address bar
- 13 Displayed yahoo website
- 14 Type the word child Image on text box and click search tab
- 15 Choose images tab
- 16 More child images are displayed
- 17 Choose any one image
- 18 Double click the image
- 19 Select the image and Right click the mouse button
- 20 Click Save picture as in Fig 3



- 21 Choose saving location on image.
- 22 Click Save button.
- 23 Get the work checked by the Instructor.

---

#### TASK 5 : Downloading the Software

- 1 Type the text [google.com](http://google.com) on internet explorer address bar.
- 2 Display the google website.
- 3 Type the text "download winzip software" on text box.
- 4 Click Search button.
- 5 More download link displayed.

- 6 Click any one link.
- 7 Click Download.
- 8 Choose saving location.
- 9 Click Saved button.
- 10 Get the work checked by the Instructor.

### TASK 6 : **Creating a new mail account**

- |   |   |
|---|---|
| 1 Type the text <b>www.gmail.com</b> on internet explorer address bar | 5 Fill all the columns.                   |
| 2 Open Gmail website.   | 6 Finally click I accept button.          |
| 3 Click Sign up for Gmail link.                                       | 7 Created your own gmail account.         |
| 4 Open the Application window.  | 8 Get the work checked by the Instructor. |
- 

### TASK 7 : **Opening the Mail Account**

- |   |   |
|---|---|
| 1 Type the text www.gmail.com on internet explorer address bar. | 5 Open mail window.                       |
| 2 Open Gmail website.   | 6 Check Inbox.                            |
| 3 Type the user name and password.                              | 7 Inbox means received mail.              |
| 4 Click Sign in button.   | 8 Get the work checked by the Instructor. |
- 

### TASK 8 : **Composing email**

#### **Step 1**

- |  |                               |
|--|-------------------------------|
| 1 Click Compose mail button.                                     | 7 Click Open button.          |
| 2 Display writing mail window.                                   | 8 Display message.            |
| 3 Type the To address : example <b>rajesh_143@rediffmail.com</b> | 9 Type the body text.         |
|  | 10 Check the spelling.        |
|  | 11 Finally click send button. |

#### **Step 2**

- |  |  |
|--|--|
| 4 Type the Subject : example : Reg. Leave request. | 12 Click Sent mail option.                 |
| 5 Click Attach a file option.                      | 13 Displayed sending mail report.          |
| 6 Choose location for attached file.               | 14 Get the work checked by the Instructor. |
- 

### TASK 9 : **Checking Inbox**

- |  |   |
|--|---|
| 1 Check Inbox button                         | 4 Click the latest mail.                  |
| 2 One mail received is notified by inbox(1). | 5 Mail will be displayed.                 |
| 3 From address Rajesh Kannan                 | 6 Get the work checked by the Instructor. |
- 

### TASK 10 : **Creating a New Mail account in Yahoo site**

- |   |   |
|---|---|
| 1 Type the address www.yahoo.com on internet explorer address bar | 6 Display application window                      |
| 2 Open yahoo web site   | 7 Compulsory Fill all column your details.        |
| 3 Click mail option.  | 8 Finally click these button " create my account" |
| 4 Open email window   | 9 Display window for account created.             |
| 5 Click signup link.  | 10 Get the work checked by the Instructor.        |
- 

### TASK 11 : **Entering the yahoo mail**

- |   |  |
|---|--|
| 1 Type the mail id and password         | 7 Check Trash                              |
| 2 Click Sign.                           | <b>Check the Inbox</b>                     |
| 3 Enter the mail account                | 8 Check the inbox button (1 mail received) |
| 4 Check Inbox button (received 1 mail). | 9 Click inbox                              |
| 5 Check Spam mail (received 1 mail)     | 10 Display mail message                    |
| 6 check online user.                    | 11 Get the work checked by the Instructor. |
-

**TASK 12 : Replying the mail**

- 1 Click the Reply link.
- 2 Display the compose window.
- 3 Automatically typed sender mail address.
- 4 Automatically subject typed sender subject.
- 5 Only typed message.
- 6 Finally click Send button.

**Removed your Mail**

- 7 Click received mail check box.

- 8 Click Delete button.
- 9 Deleted your current selected mail.
- 10 Displayed window for only one mail balanced.

**Check Contacts**

- 11 Click Contacts link.
- 12 Displayed all contacts name.
- 13 Get the work checked by the Instructor.

-----

**TASK 13 : Creating a New Folder**

- 1 Choose My Folder window.
- 2 Click Add link (right side).
- 3 Created folder name by default in untitled.

- 4 Type the folder name "Personal".
- 5 Folder "Personal" is created.
- 6 Get the work checked by the Instructor.

-----

**TASK 14 : Renaming the Folder**

- 1 Select the Folder.
- 2 Right click the mouse button
- 3 Click Rename option.

- 4 Type folder name.
- 5 Get the work checked by the Instructor.

-----

**TASK 15 : Deleting the Folder**

- 1 Select the Folder.
- 2 Right click the mouse button.
- 3 Click Delete option.

- 4 Deleted the selected folder.
- 5 Get the work checked by the Instructor.

-----

**TASK 16 : Moving to Folder**

- 1 Select the received mail.
- 2 Click the check box.
- 3 Click the Move button.
- 4 Displayed all created folder.
- 5 Select personal folder.

- 6 Moved to personal folder successfully.
- 7 Displayed message for There are no messages in the inbox folder.
- 8 Check the personal folder.
- 9 Successfully moved to personal folder one mail.
- 10 Get the work checked by the Instructor.

-----

**Prepare terminations, make UTP and STP cable connectors and test**

**Objectives :** At the end of this exercise you shall be able to

- prepare a UTP cross cable ends for making connection to the computer
- test the cable with LAN tester.

Requirements			
Tools/Equipments/Instruments		Materials/Components	
• Desktop computers	- 2 Nos.	• RJ - 45	- 1 No.
• Crimping tool	- 1 No.	• RJ - 11	- 1 No.
• LAN tester	- 1 No.		

**PROCEDURE**

**TASK 1: Prepare a UTP cross cable ends for making connection to the computer**

The instructor has to arrange the required length of cross cable, the tool for crimping and two computer for making connection as shown in Fig 1.

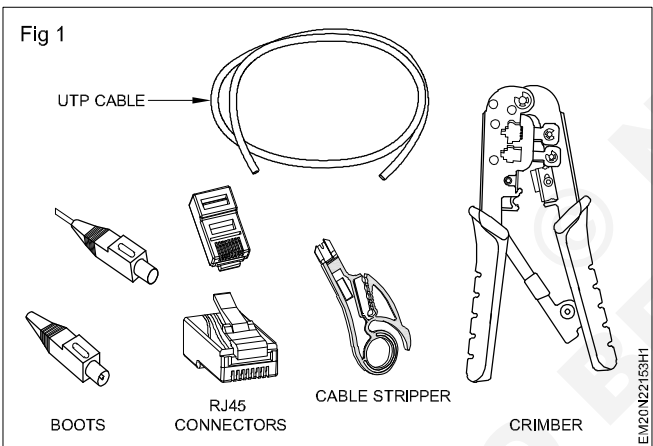

- 1 Use crimping tool as shown in Fig 2 to cut through a cable and strip the cable jacket/insulation using cable stripper/crimping.

Crimp tools have two blades. One designed to cut the cable and other to strip the jacket. While stripping the cable care should be taken not to cut the internal wires. Remove the jacket insulation about an inch. When the jacket insulation removed you will find eight wires twisted into four pair for CAT 5 cable as in Fig 3a and a separator inside the CAT6 cable as shown in Fig 3b.

- 2 Cut the separator off and untwist the wires back to within one-eighth inch of the jacket.
- 3 Arrange the wires from left to right in the order they are to be crimped. The normal crimping order for cross cable is shown in Fig 4a & Fig 4b.

The colour code wiring order is different for both ends in cross cable

- Cross over cable
- One end

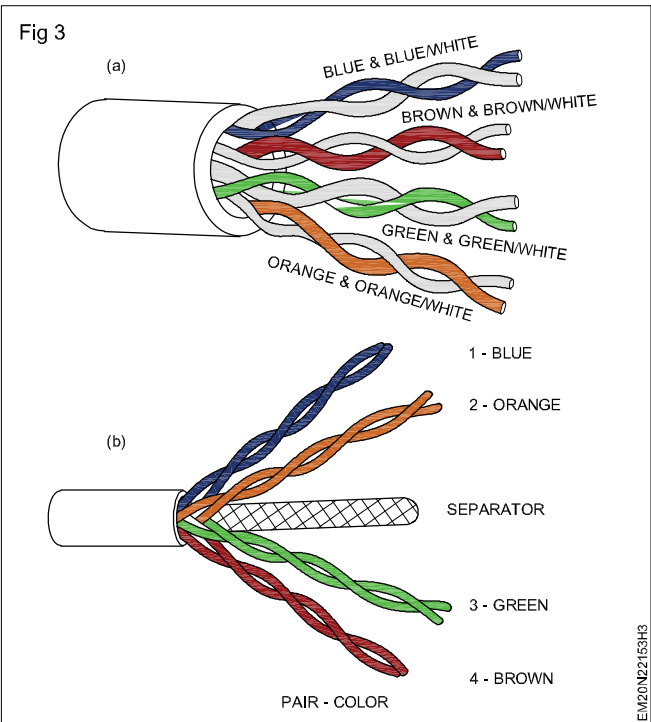
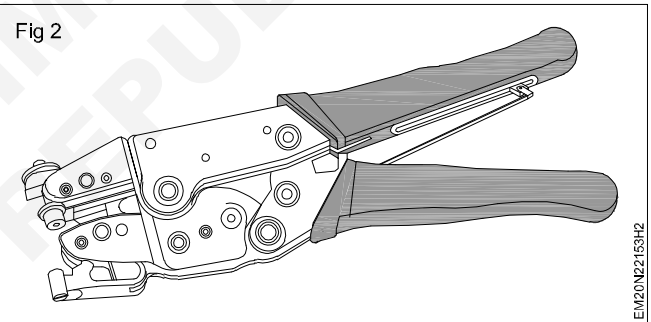

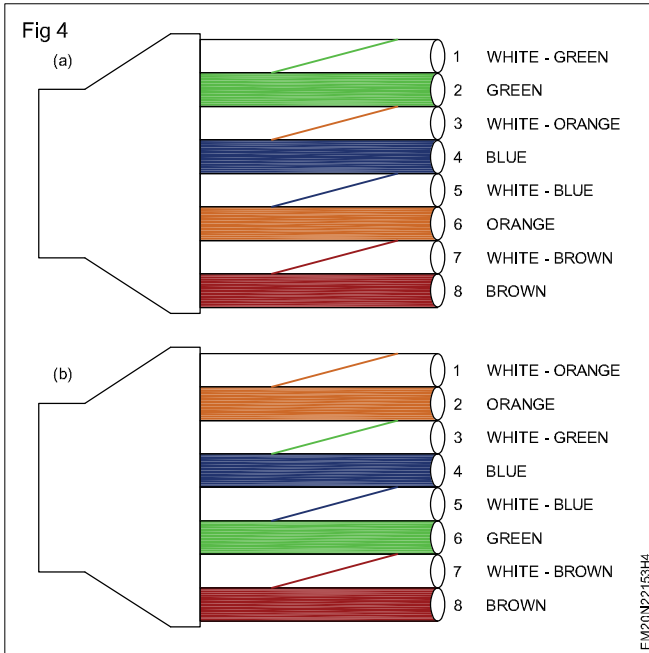

4 Grasp the wires firmly between your fingers and flatten them to remove the curliness

**The wires must lay flat and together aligned as closely as possible in order. when finished the cable should look like as shown in Fig 5.**

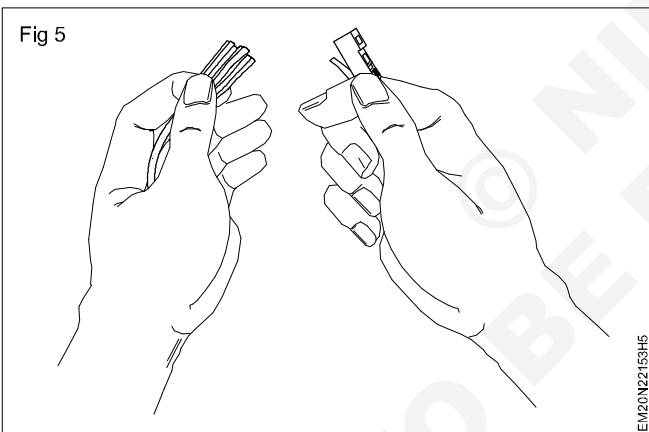

5 Cut a few mm while holding them firmly, so they are all of the same length as shown in Fig 6.

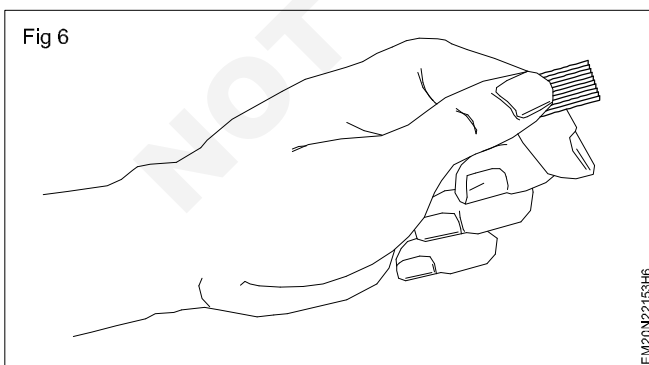

6 Slide the RJ45 connector on to the wires making sure the wires stay lined up

**Try to make each wire fits in the slot of the connector and make each wire reach the end of its slot. The cable jacket/insulation should reach just beyond the end of the crimp point as shown in Fig 7.**

**Fig 7**

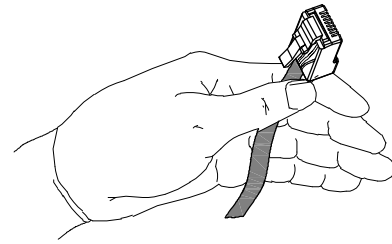

7 Verify all the wires are in the correct order, and insert the connector in to the crimping tool and press to crimp as shown in Fig 8

**Fig 8**

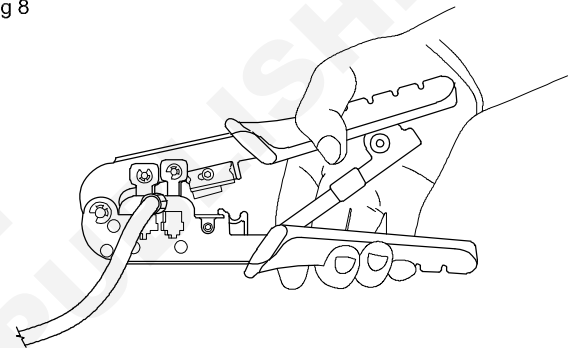

**Now half of the work done. The cable should look like as shown in Fig 9. The process must be repeated for the other end of the cable. However the colour code wiring order changes for cross cable as shown in Fig 10.**

**Similarly straight through cable and roll over cable can be prepared with the help of the instructor. The colour code wiring order is shown in Fig 11.**

**Fig 9**

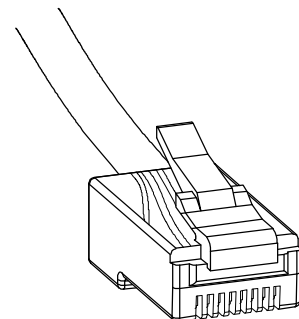

- 1 Green White
- 2 Green
- 3 Orange White
- 4 Blue

- 5 Blue White
- 6 Orange
- 7 Brown White
- 8 Brown

Fig 10

PIN ID	SIDE A	SIDE A
1	ORANGE - WHITE	GREEN - WHITE
2	ORANGE	GREEN
3	GREEN - WHITE	ORANGE - WHITE
4	BLUE	BROWN - WHITE
5	BLUE - WHITE	BROWN
6	GREEN	ORANGE
7	BROWN - WHITE	BLUE
8	BROWN	BLUE - WHITE

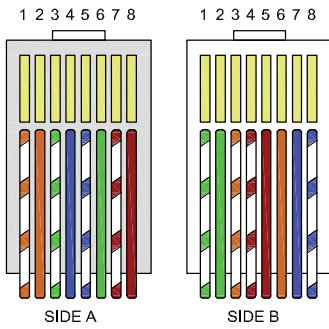

EM20N22153HA

**Cross over cable is used to connect between two hosts (PC's). Straight-through cable is used in network when connecting a host to a switch. A rollover cable is used in a networking environment where a outer/switch is to be configured from a computer. One end is wired one way but on the other it is reversed. You would typically use on end into a serial port on a PC and the other into the console port of the switch/router**

Fig 11

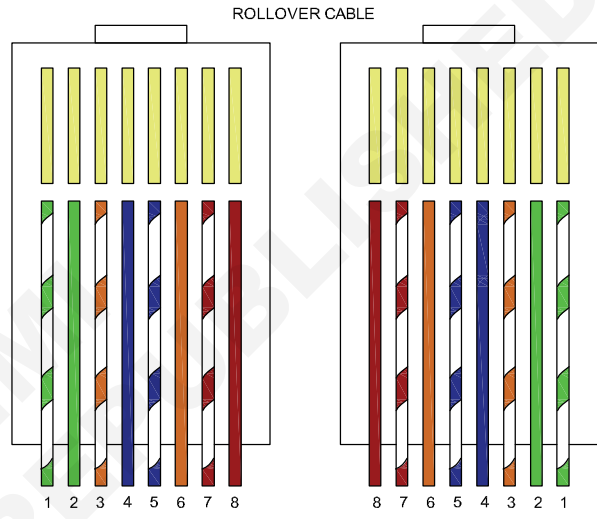
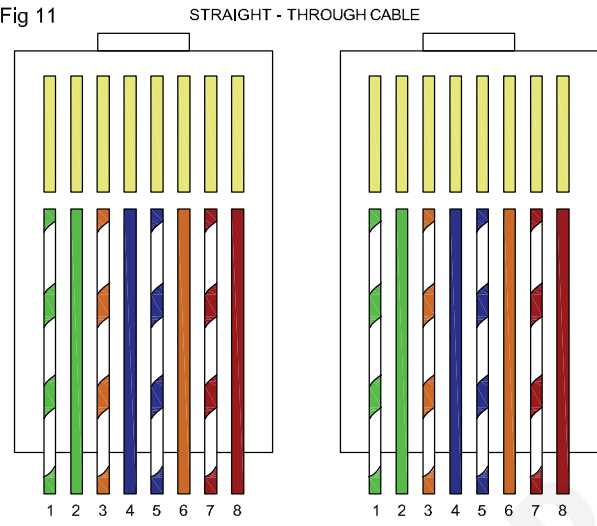

EM20N22153HB

**TASK 2: Testing the cable with the LAN tester**

- 1 Insert one end of the cross cable (prepared in Task 1) into one socket and other end in another plugged in socket of the LAN tester as shown in Fig 1

- 2 Switch 'ON' the LAN tester.
- 3 Note the order in which LED's glowing in both the panel of the LAN tester should correspond to the order shown in Fig 2

If the LED's doesn't glow, then there is a break in the cable.

Fig 1

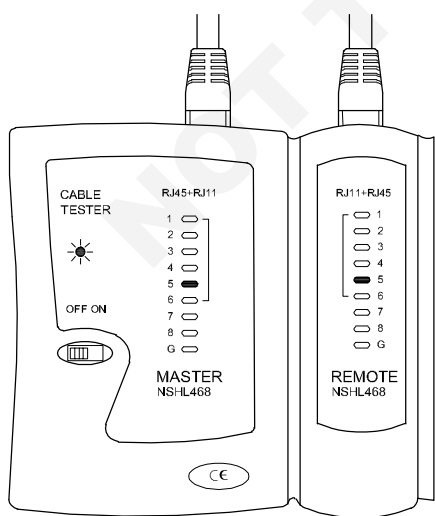

EM20N22153HC

Fig 2

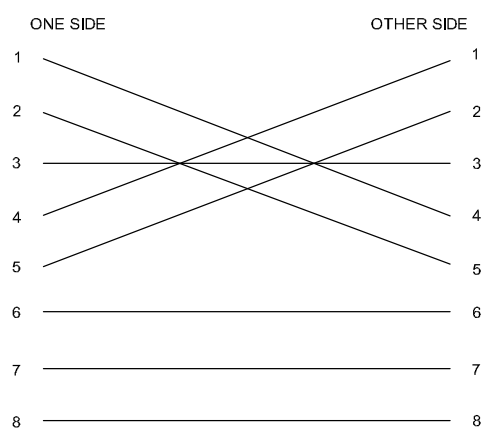

EM20N22153HD

**Check for the batteries loaded in cable tester**



### Configure a wireless Wi-Fi network

**Objectives:** At the end of this exercise you shall able to

- check Wi-Fi hardware
- connect Wi-Fi network
- disconnect Wi-Fi network.

#### Requirements

##### Tools/Equipments/Instruments

- Desk top computer or Laptop - 1 No.
- wifi hardware installation - 1 No.

### PROCEDURE

#### TASK 1 : Checking the availability of the wifi hardware and installation

- 1 Open the control panel and check the Network adapters for the Wi-Fi.

Fig 1

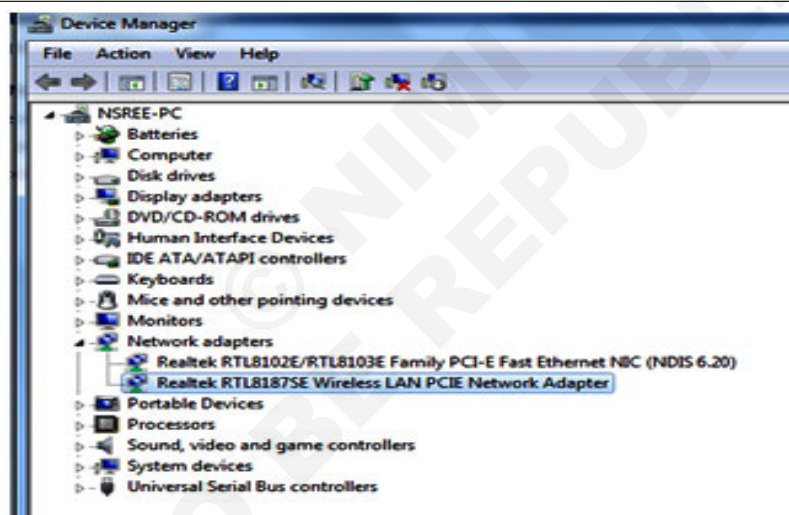

- 2 Check the proper working of Wi-Fi device using properties.

Fig 2

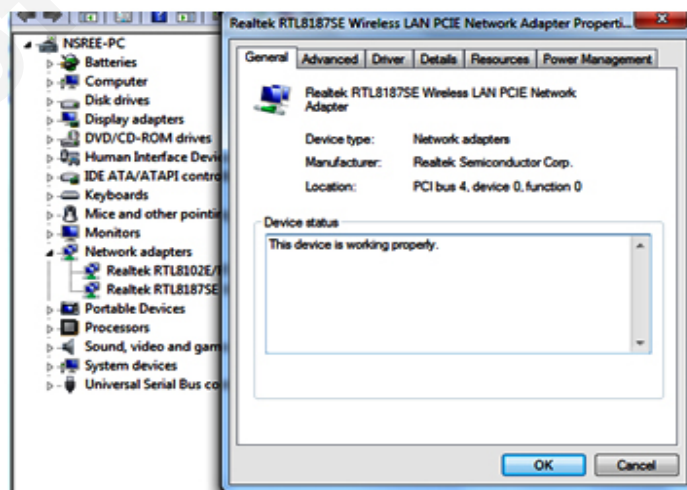

- 3 Install a device if not found in the system as external Wi-Fi dongle.
- 4 Install driver for the device using CD or Internet download.
- 5 Check in the device manager for successful installation.
- 6 Get the work checked by the Instructor.

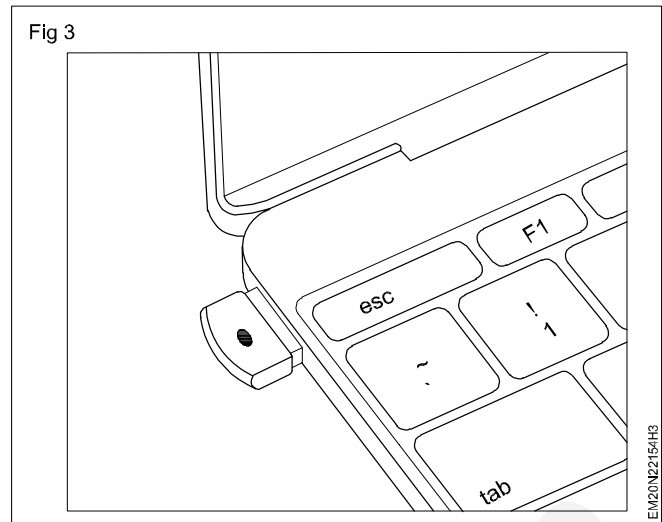

-----

### TASK 2 : Connecting a Wi-Fi network

- 1 Click the wireless icon in the notification area.
- 2 Select the network to connect.
- 3 Check the Connect automatically option.
- 4 Click the Connect button
- 5 Enter the network security key.

- 6 Click the Next button.

**Note :If the network flyout is not reporting any wireless network, try the steps shown below to turn off and on again Wi-Fi to see if that fixes the problem.**

- 7 Get the work checked by the Instructor.
- 

### TASK 3: Disconnecting of Wi-Fi network

- 1 Click the wireless icon in the notification area on the task bar.
  - 2 Select the network that is currently connected.
  - 3 Click the Disconnect button on the network connection.
  - 4 Get the work checked by the Instructor.
- 

**Note :Alternatively, click the quick action Wi-Fi button at the bottom to turn off the adapter and disconnect from the network using flyout menu. The same Wi-Fi button can also be found in the Action Center's Quick Actions section (Windows key + A).**

Electronics Mechanic - Basic SMD (2,3,4 terminal components), soldering and desoldering

Identification of 2,3,4 terminal SMD components

**Objectives :** At the end of this exercise you shall be able to

- identify the 2,3,4 terminal SMD components
- identification of value of SMD resistor
- identification of SMD capacitors
- identification of SMD diodes and transistor.

Requirements	
<p><b>Tools/Equipments/Instruments</b></p> <ul style="list-style-type: none"> <li>• Trainees tool kit - 1 Set.</li> <li>• ESD table with wrist strap - 1 Set.</li> <li>• Digital multimeter with probes - 1 No.</li> <li>• <b>Aids:</b> SMD components chart - 1 No.</li> </ul>	<p><b>Materials/Components</b></p> <ul style="list-style-type: none"> <li>• Assorted 2,3 &amp; 4 terminal SMD components (Resistors capacitors, transistors, ICS) - as reqd.</li> <li>• SMD data sheet - 1 No</li> <li>• Magnifying glass - 1 No</li> </ul>

PROCEDURE

TASK 1 : Identification of 2,3,4 terminal SMD components

**NOTE:** The instructor has to provide different SMD resistors, capacitors, diodes, transistors.

**SAFETY PRECAUTION:** Wear the wrist strap and ensure that the ESD belt is properly grounded before touching any SMD components.





- 1 Identify 2,3 or 4 terminal SMD components from the assorted group of SMD components.
- 2 Separate the SMD components as per the number of terminals (i.e. 2,3 or 4 terminals).
- 3 Record the code marked on it in Table 1.
- 4 Identify the component & its value specifications using reference Chart -1.
- 5 Repeat the above steps for all the SMD components provided.
- 6 Get the work checked by the Instructor.

Table 1

Sl.No	No.of terminals	Code No. marking	Identified component	Remarks

Chart 1

Shape and markings of some common SMDs

Component	Shape	Makings
Chip resistor		Labeled with value
Chip capacitor		Not marked
Diode		Cathode end marked with notch or band
SOT (Small outline Transistor)		May be marked, unmarked, or house numbered, pin one marked with beveled side, dot, band or notch

**TASK 2: identification of value of SMD resistor**

- 1 Pick one of the SMD resistor and refer to the Fig 1a&b identify the coding marked on the component

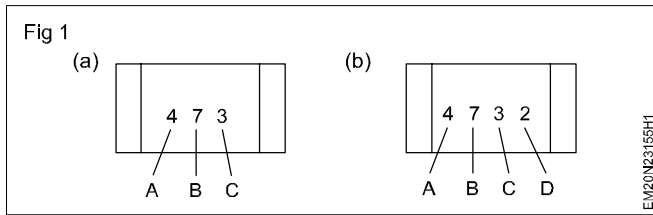

- 2 Decode the value referring to the Chart 1 & Chart 2
- 3 Record the observations in Table 1

Resistors are frequently marked with a three digit number and some typical values are shown in chart 4. The first two numbers are the significant digits of the value, and the last digit is the multiplier (the number of zeros to add to the first two digits). For example, a chip resistor labeled 102 has a value of 1000 Ohms, or 1k Ohms.

**Marking on the SMD resistors**

- A = 1st digit of the resistors value
- B = 2nd digit of the resistors value
- C = number of zeros

**Chart - 1**

Code letters printed	Resistance value
101	100 Ω
471	470 Ω
102	1k Ω
122	1.2k Ω
103	10k Ω
123	12k Ω
104	100k Ω
124	120k Ω
474	470k Ω

**Typical resistor markings and corresponding values**

- A = 1st digit of the resistor value
- B = 2nd digit of the resistor value
- C = 3rd digit of the resistor value
- D = number of zeros

- 4 By using the above technique, find values of resistors for those components whose values are printed as below and record in Table 2

**Chart 2**

Printed code letters	Resistance Value
100R	100 Ω
634R	634 Ω
909R	909 Ω
1001	1k Ω
4701	4.7k Ω
1002	10k Ω
1502	15k Ω
5493	549k Ω
1004	1M Ω

**Table - 1**

Code letter printed	Resistance Value
102	--- Ω
470	--- Ω
103	--- Ω
222	--- Ω
101	--- Ω
232	--- Ω
333	--- Ω
1243	--- Ω
4743	--- Ω

**TASK 3: Identification of SMD capacitors**

**NOTE:** Ceramic multilayer chip capacitors are available with a very wide range of values, from 0.47 pF to 1uF. These values are covered by seven cases forms. The forms depends on the capacitors values. The most popular case are 0805 and 1206.

**PRECAUTION:** Be very careful with non-marked components Avoid mixing them. SMD tantalum capacitors are available in different case forms, partly without printed values. The + polarity is marked by white line, or white "M". The case forms depend on capacitance value and nominal voltage.

**1 Coding with digits**

- 1 Pick one of the SMD capacitor, refer to the Fig. 1,2,3 & 4 and identify the type, coding marked on the capacitor.
- 2 Decode the values referring to Chart - 1 find the value.
- 3 Record the observed calculated value in Table 1.
- 4 Get the work checked by the instructor.

**Example**

Description "224" means  $220\ 000\ \text{pF} = 220\text{nF} = 0.22\ \mu\text{F}$

**2 Coding with alphanumerical characters**

**Chart 1**

<b>Capacitance pF</b>	1	1.5	2.2	3.3	4.7	6.8
<b>Code</b>	A	E	J	N	S	W
<b>Multiplicator</b>	$10^5$	$10^6$	$10^4$	$10^3$	$10^2$	$10^1$
<b>Code</b>	5	6	4	3	2	1

Nominal voltage code (first digit from left)

Volt	4	6.3	10	16	20	25	35
Code	G	J	A	C	D	E	V

**Example 1**

- 1 1.0 pF, 16V ... CA
- 2 2.2 pF, 6.3V ... JJ

**Example 2**

- A6.....  $1.0 \times 10^6$  pF=1.0  $\mu\text{F}$   
 J5.....  $2.2 \times 10^5$  pF=0.22  $\mu\text{F}$   
 FJ6.....  $2.2 \times 10^6$  pF=2.2  $\mu\text{F}$

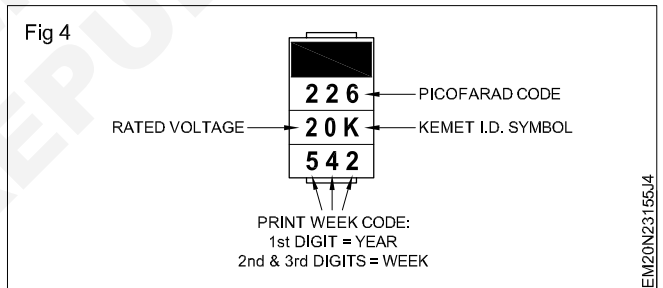
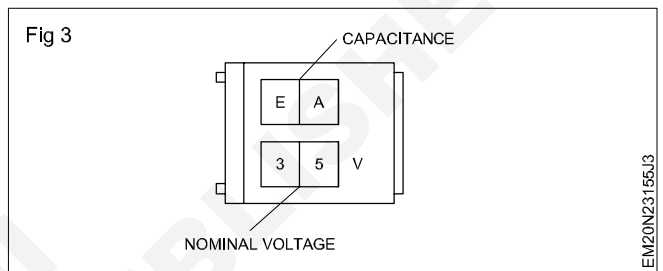
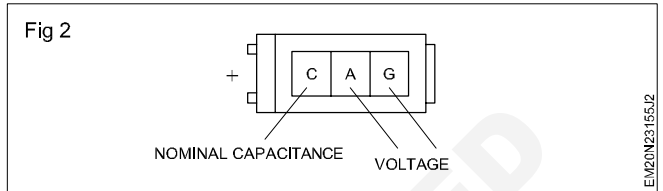
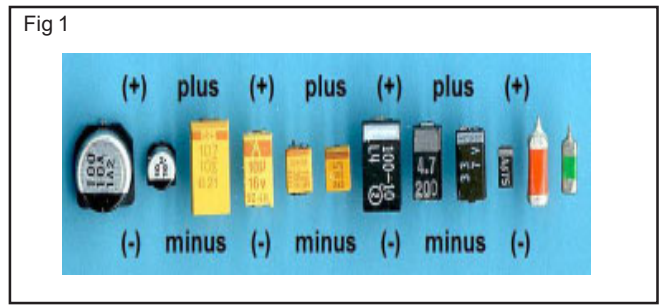
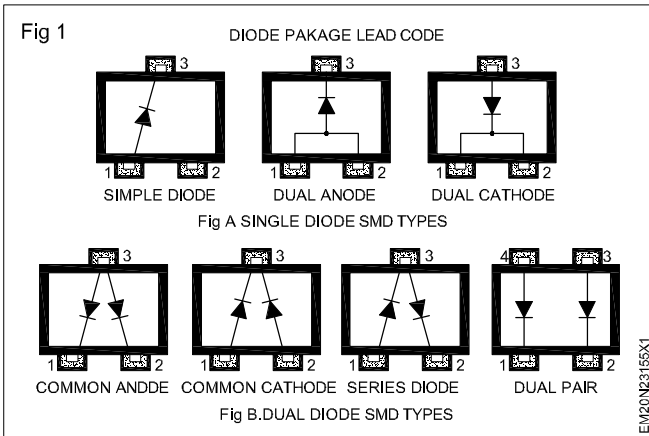

**Table 1 - Capacitor Values**

Package	Code on capacitor SMD	Calculated Value
		..... $\mu\text{F}$
		..... $\mu\text{F}$
		..... $\mu\text{F}$
		..... $\mu\text{F}$
		..... $\mu\text{F}$
		..... $\mu\text{F}$
		..... $\mu\text{F}$
		..... $\mu\text{F}$

**TASK 4: Identification of SMD Diodes and Transistor**

- 1 Pick one of the SMD diode, from the sorted SMD components using marking provided on the surface.
- 2 Refer Fig 1 and identify the type. Write down the code in Table 1.



Almost all standard diodes are available as SMD components in SOT-23, SOT-89 and SOT-143 cases, In general electrical parameters of SMD diodes are the same as comparable standard types in conventional cases. SOT -23 and SOT - 143 cases are used for components with power dissipation 200 to 400 mW. SOT - 89 cases are used for power dissipation 500mW to 1W

SMD LEDs are available in SOT - 23 cases.

By using above package types separate the diode and test it by using multimeter.

- 3 Select the diode testing mode on the digital multimeter, check the diode in forward and reverse directions.
- 4 Enter the observation on Table 1.

**Table - 1**

SI.No.	Package Type	Forward Resistance Value	Reverse Resistance Value

- 5 Pick one of the SMD transistor and with the help of Fig 2 identify the terminals.
- 6 Record the package type and the observations in Table 2

**Table - 2.**

SI. No.	Package	Types of component	Test carried out	Remarks

- 7 Repeat the above steps for all the remaining diodes.

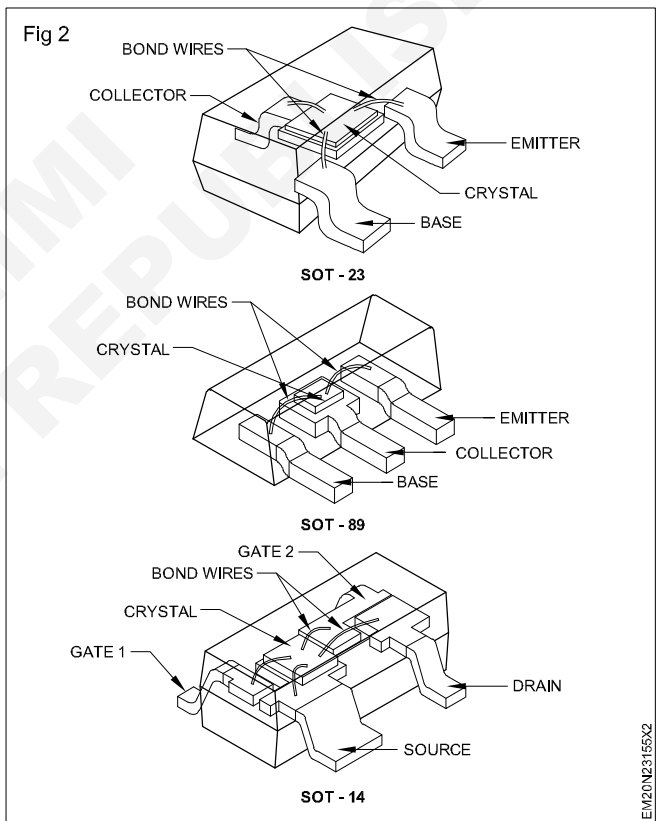

- 8 Get the work checked by the instructor.

Electronics Mechanic - Basic SMD (2,3,4 terminal components), soldering and desoldering

Desolder the SMD Components from the given PCB

**Objectives :** At the end of this exercise you shall be able to

- desolder the SMD Components from the PCB following different methods
- desolder the SMD Components using hot air.

Requirements			
Tools/Equipments/Instruments		Materials/Components	
• Trainees tool kit	- 1 Set.	• Desoldering wick	- as reqd.
• Magnifier with lamp	- 1 No.	• Solder flux pen/Liquid flux	- as reqd.
• SMD rework station with hot air nozzles/temperature/flow controller with Instruction Manual	- 1 Set.	• IPA Cleaning solution	- 1 bottle.
• DMM with Probes	- 1 No.	• Piece of Medium Density Fiberboard (MDF)	- 1 No.
		• Tweezers	- 1 No.

PROCEDURE

TASK 1 : Desoldering the SMD component from the PCB

- 1 Collect the defective SMD-PCB from the Instructor and identify the components to be removed.
- 2 Use magnifying glass and inspect the size of solder joints on the components to be removed as shown in the Fig 1

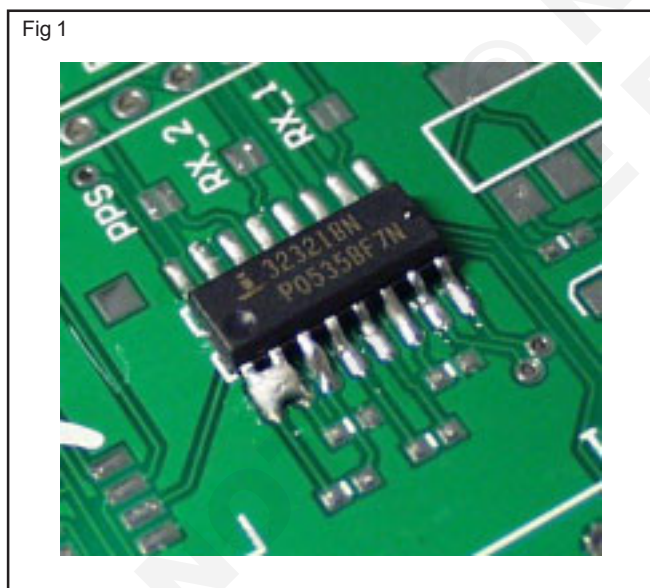

- 3 Apply a small quantity of flux and solder to the joints of the surface mount components to be removed.
- 4 Place one end of solder wicking braid on the component lead side and the tip of the soldering iron over it as shown in Fig 2

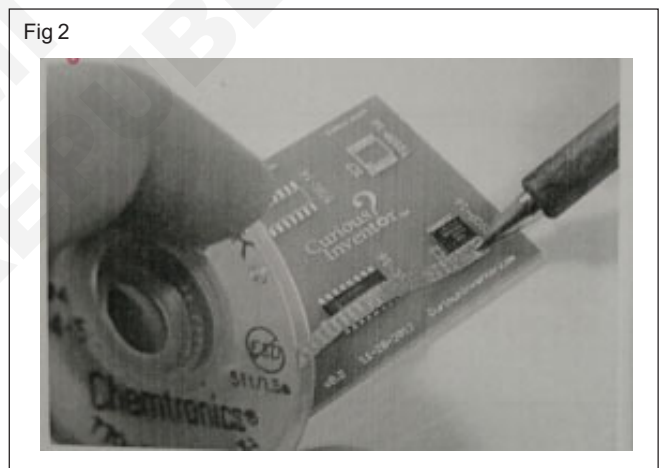

- 5 Allow time for the solder to melt and the solder wick to draw the molten solder into the braid by capillary action.
- 6 After the molten solder has been extracted from the joint, remove the wick and the soldering iron tip from the component lead.
- 7 Use the unused portion of the wick for removing excess solder.
- 8 Repeat the steps 3 to 7 for removing other terminals of the surface mount components.
- 9 Remove the components from the PCB and clean the surface, using IPA solution.
- 10 Get the work checked by the Instructor.

## TASK 2 : Desoldering SMD components using hot air

**Note: Use the MDF board to avoid damage to the Workbench or any surface made of plastic by the hot air.**

- 1 Choose the appropriate hot air nozzle tip for the desoldering work attach and tighten it using screw driver.
- 2 Power ON the soldering rework station and adjust the hot air and temperature knobs to suit the work.

**Note: It is recommended to set the air flow and temperature knobs at the middle and test on a small component, then readjust them to the required level around 275°C.**

- 3 Aim the hot air nozzle at the SMD component and move it slightly back and forth until the solder begins to melt.
- 4 Use tweezers and carefully grab/lift the SMD component from the board.

### Caution:

- 1 Aim the hot air gun at the same point will melt the board after a certain period of time
  - 2 Make sure to keep the hot air gun moving to prevent any damage to the heat sensitive component/PCB burning.
- 5 Adjust the air flow and temperature setting knobs back to zero position after finished the SMD component desoldering work.
  - 6 Switch OFF the soldering rework station and allow it to cool down.
  - 7 Clean the board using IPA solution with brush.
  - 8 Get the work checked by the Instructor.



Electronics Mechanic - Basic SMD (2,3,4 terminal components), soldering and desoldering

Solder the SMD components in the same PCB

**Objectives :** At the end of this exercise you shall be able to  
 • solder the SMD components on the PCB.

Requirements	
Tools/Equipments/Instruments	Materials/Components
<ul style="list-style-type: none"> <li>• Trainees tool kit - 1 Set</li> <li>• Magnifier with lamp - 1 No.</li> <li>• SMD soldering work station (hot air temperature/flow controller) with all accessories (and instruction manual) - 1 Set</li> <li>• Vacuum pick up tool - 1 No.</li> </ul>	<ul style="list-style-type: none"> <li>• Rosin cored solder wire - as reqd.</li> <li>• Flux pen/Liquid flux - as reqd.</li> <li>• IFA cleaning solution - 1 bottle</li> <li>• Piece of medium density fiber board - 1 No.</li> <li>• Crocodile clips holder (MDF board) - 2 Nos.</li> <li>• Solder paste tube/syringe - 1 No.</li> <li>• Cleaning brush - 1 No.</li> </ul>

PROCEDURE

- 1 Choose and fit the appropriate tip for the soldering iron suitable to the SMD component onto the PCB.
- 2 Use crocodile clips to hold the PCB firmly on the workbench.
- 3 Select the SMD components and note down the location/direction on the PCB to be soldered.
- 4 Switch ON the soldering workstation and adjust the temperature setting knob around 275°C.
- 5 Keep the SMD component over the pads on the printed circuit at its position correctly.
- 6 Use flux pen and apply a little quantity on the places where soldering has to be done.
- 7 Cut the solder wire into small pieces and place them on SMD component leads.
- 8 Hold the component using tweezers and apply the hot soldering iron tip over the solder pieces to melt.
- 9 Remove the soldering iron tip and allow the molten solder to set on the pin.

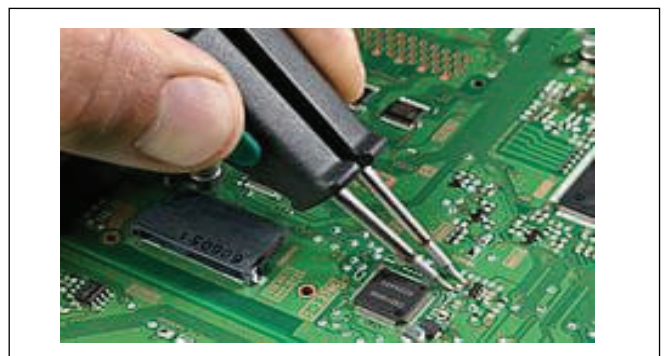
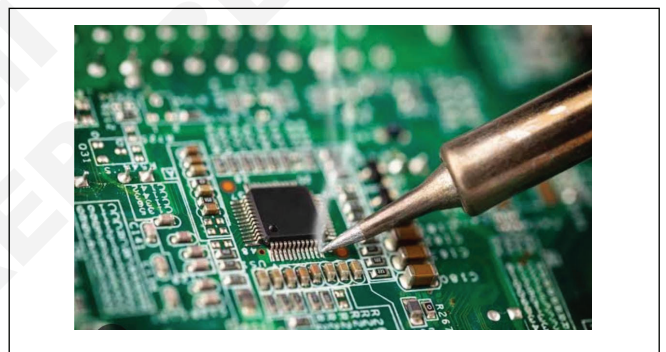

**Caution: To avoid thermal buildup, solder the terminals alternately with little time interval between pins**

- 10 Repeat steps to solder the other end of the SMD component .
- 11 Use magnifier and inspect the soldered joints are free from any solder bridges
- 12 Clean the board using IPA solution with brush
- 13 Get the work checked by the Instructor.

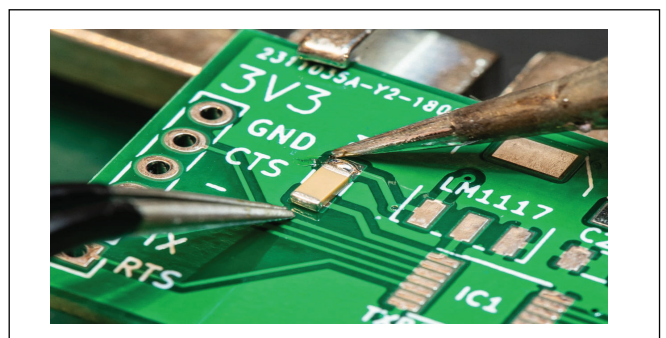

**Check for cold continuity of PCB**

**Objectives:** At the end of this exercise you shall be able to

- inspect and identify any probable defect on the given circuit board
- record the observed defect/fault on the given circuit board.

<b>Requirements</b>			
<b>Tools/Equipments/Instruments</b>		<b>Materials/Components</b>	
• Trainees tool kit	- 1 Set.	• Rosin cored solder and flux	- as reqd.
• Magnifier with lamp	- 1 No.	• IPA cleaning solution	- as reqd.
• Digital multimeter with probes	- 1 No.	• Solder flux pen/liquid flux	- as reqd.
• Soldering workstation/hot air temperature/flow controller (with instruction manual)	- 1 Set	• Cleaning brush	- 1 No.

**PROCEDURE**

**TASK 1: Identification of any defect/dry solder/short circuit on the given circuit board.**

**Note: The instructor has to simulate faults necessary in the circuit board to be given for this exercise/task.**

- 1 Collect the defective circuit board from the Instructor.
- 2 Clean the board using the brush (Use IPA solution if needed).
- 3 Visually inspect for any physical damages like cracks/ burnt/dry soldered leads of all the major components on the PCB.

- 4 Use magnifier and carefully observe for any broken tracks on the board.
- 5 Use Ohm meter and check for any short/open circuit between tracks.
- 6 Record the observations in Table 1.
- 7 Get the work checked by the Instructor.

**TASK 2 : Record and observed defect / fault on the given circuit board**

**Table - 1**

SI.No	Details of fault/defect identified		Types of defect Open/short circuit	Remarks
	Dry Solder	Loose connection		
1				
2				
3				
4				
5				
6				
7				

Electronics Mechanic - Basic SMD (2,3,4 terminal components), soldering and desoldering

Identification of loose / dry solder / broken tracks on printed wired assemblies

Objectives : At the end of this exercise you shall be able to

- identify any loose/dry solder/broken tracks on the given circuit board
- record the observed defect/faults on the given circuit board.

Requirements			
<b>Tools/Equipments/Instruments</b>		<b>Materials/Components</b>	
• Trainees tool kit	- 1 Set.	• Rosin cored solder and flux	- as reqd.
• Magnifier with lamp	- 1 No.	• IPA cleaning solution	- as reqd.
• Digital multimeter with probes	- 1 No.	• Solder flux pen/liquid flux	- as reqd.
• Soldering workstation/hot air temperature/flow controller (with instruction manual)	- 1 Set.	• Cleaning brush	- 1 No.
		• jumper wire/multistranded flexible wire pieces	- as reqd.

PROCEDURE

TASK 1: Identification of any defect/dry solder/short circuit on the given circuit board

**Note: The Instructor has to simulate faults necessary in the circuit board to be given for this exercise/task**

- 1 Collect the defective circuit board from the Instructor.
- 2 Clean the board using the brush (Use IPA solution if needed)
- 3 Visually inspect and identify any loose/dry soldered components. (Fig 1 & 2)
- 4 Use magnifier and carefully observe for any broken tracks on the board.
- 5 Record the observations in Table 1.
- 6 Resolder the identified loose or dry-soldered component; use jumper wire and join the broken track.
- 7 Get the work checked by the instructor.

TASK 2 : Record and observed defect / fault on the given circuit board

Table 1

SI.No	Details of fault/defect identified		Types of defect Open/short circuit	Remarks
	Dry Solder	Loose connection		
1				
2				
3				
4				
5				
6				
7				

Fig 1

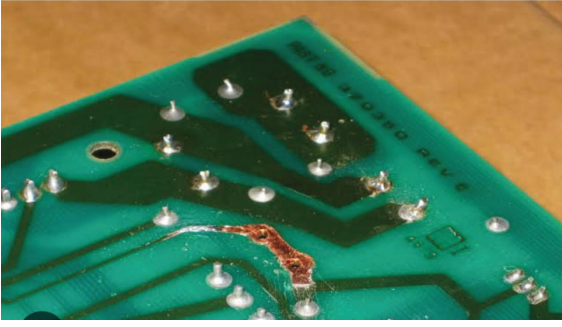
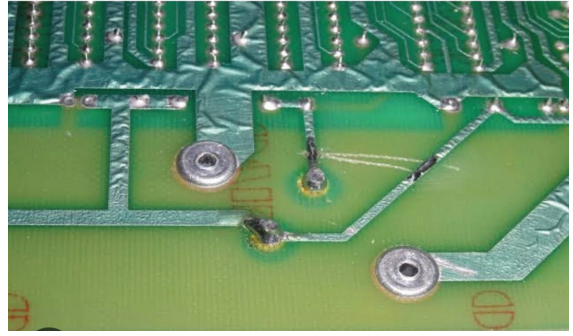

Fig 2



© NIMI  
NOT TO BE REPUBLISHED

Electronics Mechanic - Basic SMD (2,3,4 terminal components), soldering and desoldering

Identify various connections and setup required for SMD soldering station

Objectives: At the end of this exercise you shall be able to

- identify various controls/ connections on the soldering work station
- prepare the soldering work station for soldering SMD components.

Requirements	
<p><b>Tools/Equipments/Instruments</b></p> <ul style="list-style-type: none"> <li>• Trainees tool kit - 1 Set.</li> <li>• Digital multimeter with probes - 1 No.</li> <li>• SMD Soldering workstation with all accessories and operating manual - 1 Set.</li> </ul> <p><b>Aids:</b> Chart showing panel controls of soldering workstation - 1 No.</p>	<p><b>Materials/Components</b></p> <ul style="list-style-type: none"> <li>• Solder wire 60/40 rosin core - as reqd.</li> <li>• Solder flux pen/liquid flux - as reqd.</li> <li>• Cleaning brush - 1 No.</li> </ul>

PROCEDURE

TASK 1: Identification of Panel Controls/ Switches

1 Refer to the operating manual Fig 1&2. Identify the front panel controls/switches on the soldering workstation, with reference to the operating manual.

- 2 Record the name of the control/switch and its function on the Table 1.
- 3 Identify the accessories used with the soldering workstation and record them in Table 1.
- 4 Get the work checked by the Instructor.

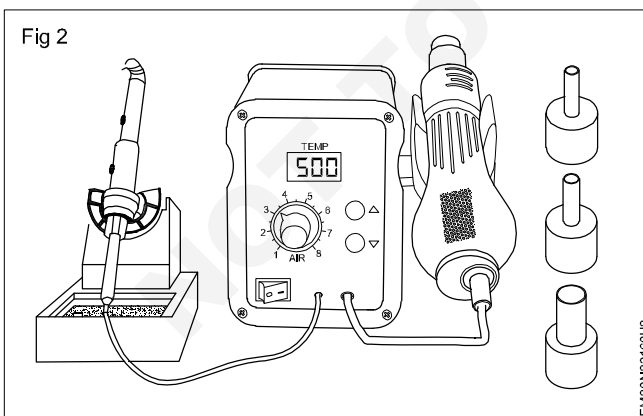
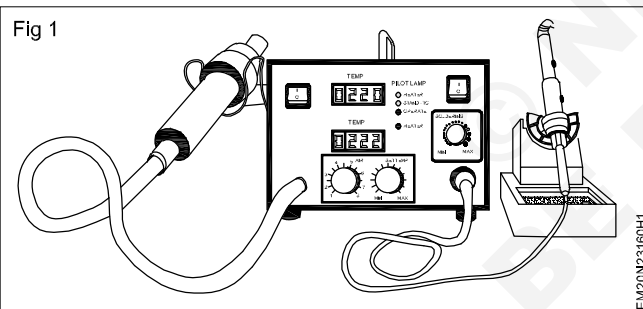

Table 1

Sl. No.	Name of the control/Switch/ accessory	Functions/Uses Specifications	Remarks

**TASK 2: Setting the soldering station for SMD Component Soldering work**

**Note: The Instructor has to ensure that all the controls/switches on the panel are kept in zero position before given to trainees.**

- 1 Select and fix the suitable bit/ tip onto the soldering iron for the SMD Component soldering work.
- 2 Select and fix appropriate size of hot air nozzle suitable for the soldering work.
- 3 Switch ON the soldering work station and set the temperature at 275°C.
- 4 Adjust the hot air pressure control knob to the mid position.
- 5 Test the soldering iron heat by keeping the solder wire on the tip for melting.

**Note: At the time of soldering SMD components, the controls may be re-adjusted for required temperature/air pressure actually needed for the soldering work.**

- 6 Record the settings control position, temperature observations on the Table-2.
- 7 Get the work checked by the Instructor and switch OFF the soldering workstation.
- 8 Refer to adjust controls on the trent the operating manual panel of the soldering workstation for 275° c temperature and record it in the Table-2 turn on soldering station
- 9 Set proper tip temperature
- 10 Now adjust the soldering workstation is ready to work for soldering / desolering
- 11 Get the worm checked by the instructor Table 2

**Table 2**

SI.No	Name of the Control/Switch	Setting/Position	Temperature/Air pressure	Remarks

**Electronics Mechanic - Basic SMD (2,3,4 terminal components), soldering and desoldering**

**Identify crimping tools for various IC packages**

**Objectives:** At the end of this exercise you shall be able to

- identify the crimping tools used for holding the ICs
- use the crimping tool during the soldering/desoldering processes of IC on the PCBs.

Requirements	
<p><b>Tools/Equipments/Instruments</b></p> <ul style="list-style-type: none"> <li>• Crimping tools - 1 Set.</li> <li>• Trainees tool kit - 1 Set.</li> <li>• Magnifier with lamp - 1 No.</li> <li>• Digital multimeter with probes - 1 No.</li> <li>• Soldering workstation/hot air temperature/flow controller (with instruction manual) - 1 Set.</li> </ul> <p><b>Aids: Wall chart showing all the special tools used for the SMD IC soldering/ desoldering of SMD components</b> - 1 No.</p>	<p><b>Materials/Components</b></p> <ul style="list-style-type: none"> <li>• Rosin cored solder and flux - as reqd.</li> <li>• IPA cleaning solution - as reqd.</li> <li>• Solder flux pen/liquid flux - as reqd.</li> <li>• Cleaning brush - 1 No.</li> </ul>

**PROCEDURE**

<p><b>Note:</b></p> <ol style="list-style-type: none"> <li>1 The Instructor has to label the tool utilized for this exercise</li> <li>2 Demonstrate the special tools used for the SMD components/ICs soldering/desoldering in the SMD PCBs along with safety precautions to handle the special tools</li> <li>3 Provide some sample SMD PCBs for this exercise</li> </ol>
--

- 1 Refer to the WallCharts showing all the special tools used for the SMD IC soldering/desoldering of SMD components as provided by the instructor and identify the name of the tool.
- 2 Record the observations on the Table 1.
- 3 Pick one of the labelled crimping tool displayed by the instructor in the table.
- 4 Use the tools, hold and grip SMD components ICs on the assembled PCBs.
- 5 Get the work checked by the instructor.

**Table 1**

Sl.No.	Label No	Name of the crimping tool	Use/application	Remarks

Electronics Mechanic - Basic SMD (2,3,4 terminal components), soldering and desoldering

Make the necessary settings on the SMD soldering workstation to desolder various ICs of different packages

Objectives: At the end of this exercise you shall be able to

- make necessary settings on the SMD soldering workstation for desoldering of ICs (different packages)
- desolder SMD ICs using wicking braid method
- desolder SMD ICs using hot air method.

Requirements		
Tools/Equipments/Instruments		Materials/Components
• Trainees tool kit	- 1 Set	• Rosin cored solder and flux - as reqd.
• Crimping tools	- 1 Set	• IPA cleaning solution - as reqd.
• Magnifier with lamp	- 1 No.	• Solder flux pen/liquid flux - as reqd.
• Digital multimeter with probes	- 1 No.	• Cleaning brush - 1 No.
• SMD Soldering workstation with operating manual	- 1 Set	

PROCEDURE

<p><b>Note:</b></p> <p>1 The instructor may use a portable stand/ fixture with crocodile clips to hold the PCB during soldering/desoldering work.</p>	<p>2 Guide the trainees to carryout this desoldering task with soldering iron/wicking braid or hot air for SMD IC assembled PCB given for this task.</p>
---	--

TASK 1 : Making necessary settings on the SMD soldering workstation for desoldering of ICs (different Packages)

- 1 Identify the SMD IC on the PCB/ assembled board.
- 2 Use magnifying glass and inspect the size of the soldered joints of the IC to be removed/ desoldered.
- 3 Select the appropriate tip/bit and fix it on to the soldering iron to be used for desoldering work.
- 4 Apply solder flux over the SMD IC pins using the 5ml syringe as shown in Fig 1
- 5 Use the fixture with crocodile clips as shown in Fig 2 to hold the board firmly on the workbench.
- 6 Switch ON the SMD soldering workstation, adjust the temperature setting knob to 275°C and keep the soldering iron ready for desoldering the SMD IC.
- 7 Use the crimping tool bent tip tweezers and hold the SMD IC.
- 8 Apply the hot soldering iron tip on the IC pins and desolder the SMD IC.



5 Use the fixture with crocodile clips as shown in Fig 2 to hold the board firmly on the workbench.

TASK 2 : Desoldering using wicking braid

- 1 Repeat Steps 1 to 6 of Task-1.
- 2 Use the desoldering wicking braid one end over the SMD IC pins as shown in Fig 1.
- 3 Keep the tip of the hot soldering iron over the wicking braid and allow time to melt the solder for few seconds.



Fig 1

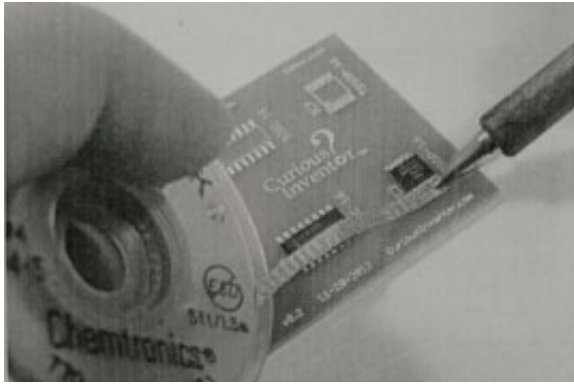

- 4 After the molten solder completely sucked by the wicking braid lift the soldering iron and wick quickly.
- 5 Use the crimping tool/bent tweezers, lift the SMD IC from the PCB.
- 6 Clean the PCB with IPA solution using brush.
- 7 Get the work checked by the Instructor

---

### TASK 3 : Desoldering using hot air

- 1 Repeat steps 1 to 6 of Task -1.
- 2 Select the nozzle size suitable to the SMD IC and fix it on the tip of the hot air gun.
- 3 Switch ON the SMD workstation and re- adjust the hot air/ soldering iron temperature according to the desoldering work.
- 4 Get the work checked by the Instructor and switch OFF the SMD workstation with both control knobs brought back to zero position and soldering iron/ hot air gun kept in their holders.

**Electronics Mechanic - Basic SMD (2,3,4 terminal components), soldering and desoldering**

**Make necessary settings on SMD soldering station to solder various ICs of different Packages**

**Objectives :** At the end of this exercise you shall be able to

- identify the suitable SMD printed circuit board to solder the SMD ICs
- solder SMD IC using soldering workstation (soldering iron type)
- solder SMD IC using soldering workstation using hot air and solder paste.

Requirements	
<p><b>Tools/Equipments/Instruments</b></p> <ul style="list-style-type: none"> <li>• ESD mat or table top and ESD wrist strap (both grounded) - 1 Set.</li> <li>• SMD soldering workstation with temperature controller/hot air flow controller with all accessories - 1 Set.</li> <li>• Magnifier with lamp - 1 No.</li> <li>• Vacuum pen - 1 No.</li> <li>• Tweezers with bent/pointed tips (ESD safe tips) - 1 No.</li> </ul>	<p><b>Materials/Components</b></p> <ul style="list-style-type: none"> <li>• Solder flux pen/liquid flux, solder wick, IPA solutions cleaning cotton bud - as reqd.</li> <li>• Solder paste - as reqd.</li> <li>• Prototype SMD PCB suitable to assemble SMD leaded IC and leadless IC - as reqd.</li> <li>• SMD IC - as reqd.</li> <li>• Flexible PCB tape - as reqd.</li> </ul>

**PROCEDURE**

Precautions
<ol style="list-style-type: none"> <li>1 Keep the workbench neat and clean.</li> <li>2 Use ESD proof bins or trays to store the components.</li> <li>3 Wear the ESD wrist strap to discharge the buildup of body static charge to ground.</li> </ol>

**TASK 1: Selecting the suitable PCB for soldering leaded SMD ICs and leadless SMD ICs**

- |  |  |
|--|--|
| <ol style="list-style-type: none"> <li>1 Use the vacuum pen and pick the given leaded SMD IC for soldering work.</li> <li>2 Check the pitch of the IC and select the suitable SMD PCB.</li> <li>3 Place the selected SMD IC on the pads of the PCB.</li> <li>4 Get the work checked by the Instructor, label the PCB as 1 and keep it separately.</li> </ol> | <ol style="list-style-type: none"> <li>5 Repeat above steps for the leadless SMD IC and label the PCB as 2 and keep it also separately.</li> </ol> |
|--|--|

Note
<ol style="list-style-type: none"> <li>1 Use the pencil bit for the soldering iron to solder the SMD IC on the PCB.</li> <li>2 Select and fix the appropriate size of hot air nozzle suitable for the soldering work.</li> </ol>

**TASK 2: Soldering leaded SMD IC using temperature controlled soldering workstation**

- |  |   |
|--|---|
| <ol style="list-style-type: none"> <li>1 Switch ON the soldering workstation and set the temperature of the soldering iron in the range of 250° - 280°C.</li> <li>2 Apply the flux on the pads of PCB 1 as shown in the Fig 1.</li> <li>3 Identify the pin no 1 of the leaded SMD IC and pick the vacuum pen and of place it correctly on the pick pad as shown in Fig 2.</li> </ol> | <ol style="list-style-type: none"> <li>4 Align/adjust the chip as shown in Fig 3 using tweezers if necessary</li> </ol> |
|--|---|

Note: Once multiple pins are soldered, it's very difficult to make adjustments without removing the chip.

Fig 1

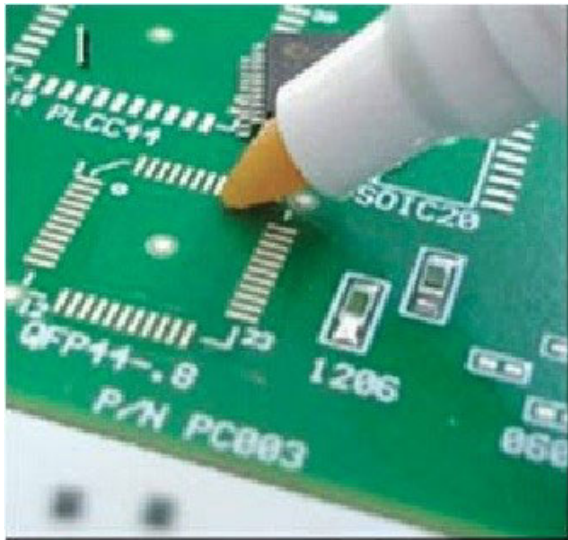
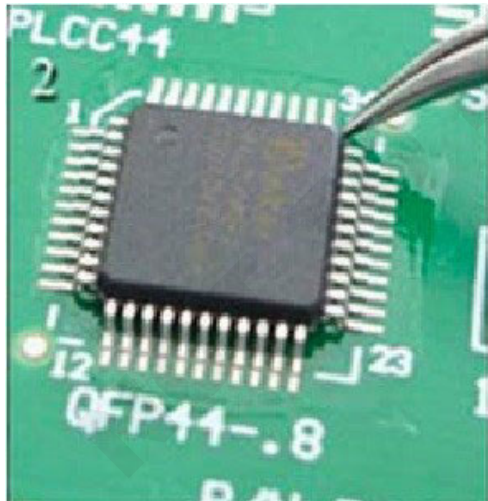

Fig 2

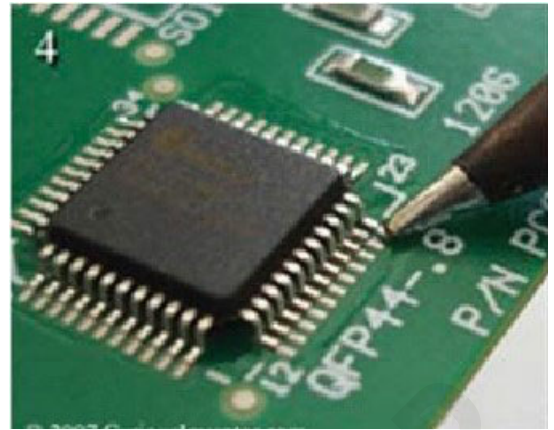

Fig 3



- 5 Use the soldering iron with a little solder on the tip solder the first pin of the IC as shown in Fig 4.

Fig 4



- 6 Check the alignment is correct through the magnifier as shown in Fig 5.

Fig 5

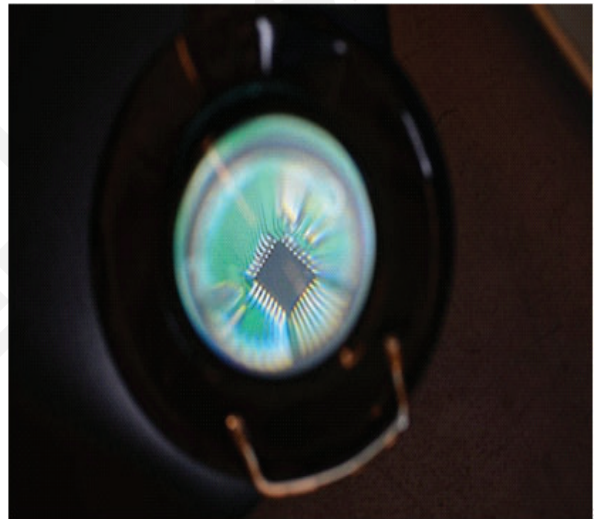

- 7 Solder the diagonal corner pin of the IC, recheck and confirm the alignment.
- 8 Apply the liquid flux over all the pins of the IC and solder the remaining pins.
- 9 Check IC terminals are perfectly soldered. If any solder bridges are formed remove them using solder wick.
- 10 Verify the solder joint using magnifier and clean the PCB with IPA solution.
- 11 Get the work checked by the Instructor.

### TASK 3: Soldering leaded SMD IC using soldering workstation hot air and solder paste

- 1 Pick the SMD IC and the PCB-2; Identify the pin-1 mark on the land pattern of the PCB as shown in Fig 1.

Fig 1

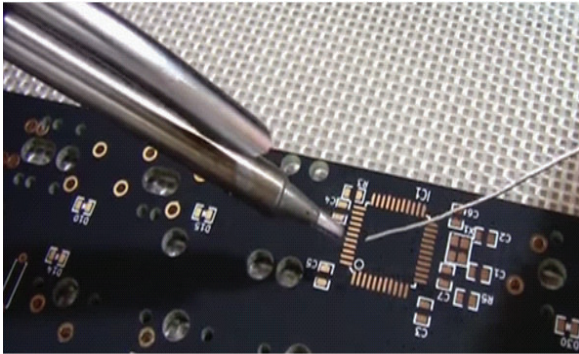

- 2 Clean the solder pad with IPA solution and tin the 1st pin, diagonally opposite pin pads.
- 3 Use holding device with crocodile clips to fix the PCB firmly on the work bench.
- 4 Switch ON the soldering workstation, adjust the temperature setting knob to 275°C.
- 5 Use the ESD safe tweezers and place the SMD IC on the pads of the PCB at its position correctly as shown in Fig 2.

Fig 2

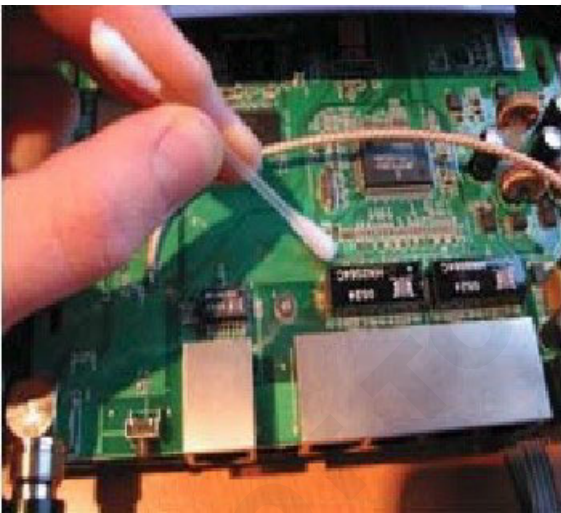

- 6 Hold the IC firmly and solder the pin-1 using pencil tip soldering iron and solder the diagonally opposite pin; switch OFF power.
- 7 Check the alignment using magnifier and confirm the SMD ICs correct position on the PCB as shown in Fig 3.

Fig 3

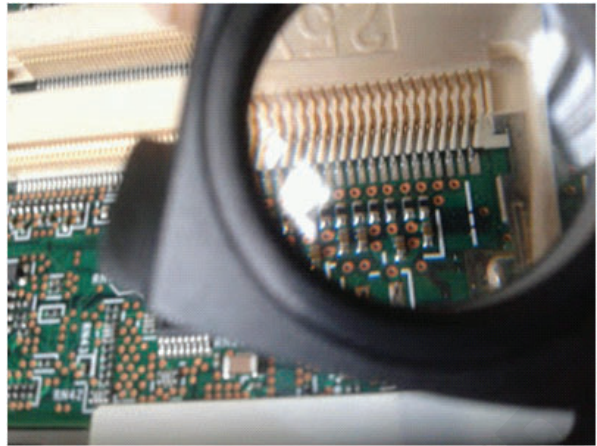

- 8 Apply the solder paste over the pins on all the four sides of the SMD IC.
- 9 Power ON the soldering workstation and adjust the air and temperature knobs to 280°C.
- 10 Apply the hot air nozzle over the SMD IC leads on all the four sides.
- 11 Keep the hot air nozzle moved around till the solder paste slowly melts and the solder joints formed on the pads of PCB.

**Caution: To avoid damage do not keep the hot air nozzle over the device and adjacent components for a longer period of time and burning of the PCB. Don't blow air by mouth; it may cause dry solder.**

- 12 Use magnifier and check all the pins of the SMD IC are correctly soldered to the pads on the PCB as shown in Fig 3.

**Note: Solder the pins using soldering iron with pencil tip if needed**

- 13 Clean the soldered PCB using IPA solution with brush
- 14 Get the work checked by the Instructor

**Repeat the above steps for various SMD IC packages like SOP, SSOP, TSOP, TSSOP, SOIC, SOT packages**

Electronics Mechanic - Basic SMD (2,3,4 terminal components), soldering and desoldering

Setting for rework of defective Surface Mount Components using soldering/desoldering method

**Objectives:** At the end of this exercise you shall be able to

- desolder the surface mount solder joint using solder wick
- desolder the SMD IC using soldering workstation/hot air
- desolder the SMD components using vacuum pump.

Requirements			
Tools/Equipments/Instruments		Materials/Components	
• Trainees tool kit	- 1 Set.	• Solder wick	- as reqd.
• Magnifier with lamp	- 1 No.	• IPA cleaning solution	- as reqd.
• ESD table/Surface with wrist strap	- 1 No.	• Solder flux pen/liquid flux	- as reqd.
• Soldering workstation/hot air temperature/flow controller (with instruction manual)	- 1 Set.	• Cleaning brush	- 1 No.
• Digital Multimeter with probes	- 1 No.	• Vacuum pen	- 1 No.
• Desoldering tool with vacuum pump	- 1 Set.	• Kapton tape	- 1 No.
		• Syringe - 5 ml	- 1 No.
		• SMD leaded IC assembled PCB	- 1 No.

**Note:** The Instructor has to ensure that the trainees are wearing the ESD strap before handling the electronic components of the PCB

PROCEDURE

TASK 1: Removal of surface mount solder joint using solder wick

- 1 Collect the defective SMD-PCB from the Instructor and identify the component to be removed.
- 2 Use magnifying glass and inspect the size of the solder joints on the components to be removed as shown in the Fig 1
- 3 Apply a small quantity of flux and solder to the joints of the surface mount components to be removed.
- 4 Place the end of solder wicking braid on the component lead side and the tip of the hot soldering iron over it as shown in Fig 2

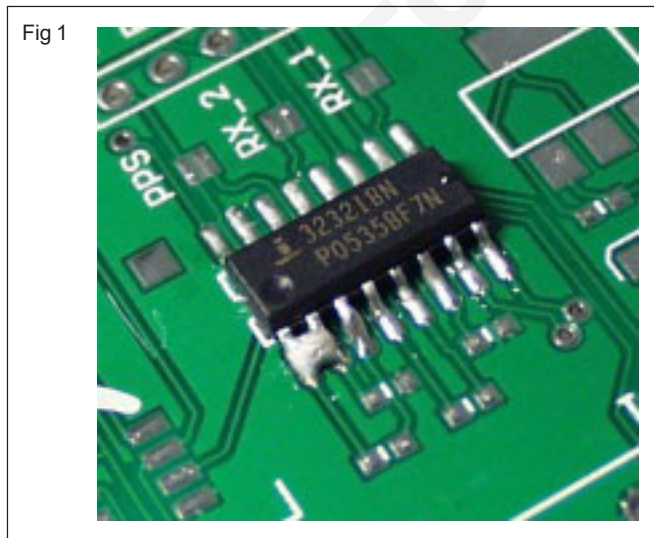

- 5 Allow time for the solder to melt and the solder wick to draw the molten solder into the braid by capillary action.
- 6 After the molten solder has been extracted from the joint, remove the wick and the soldering iron tip from the Component lead.
- 7 Use the unused portion of the wick for removing excess solder.

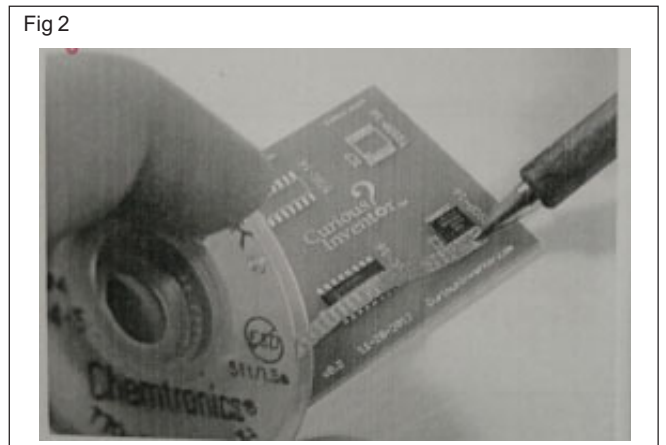

- 8 Repeat the steps 3 to 7 for removing other terminals of the surface mount components.
- 9 Remove the components from the PCB and clean the surface with IPA solution.

- 10 Get the work checked by the Instructor.

-----

**TASK 2 : Desoldering of SMD - IC using soldering workstation/hot air**

**Note: The Instructor has to ensure that the masking of the other components using Kapton tape is done before starting the desoldering of SMD - IC.**

- 1 Select the blower tip of the Soldering workstation as shown in Fig 1 suitable to the SMD - IC to be removed.

Fig 1



- 2 Apply solder flux over the SMD - IC or chip using the 5ml syringe as shown in Fig 2

Fig 2

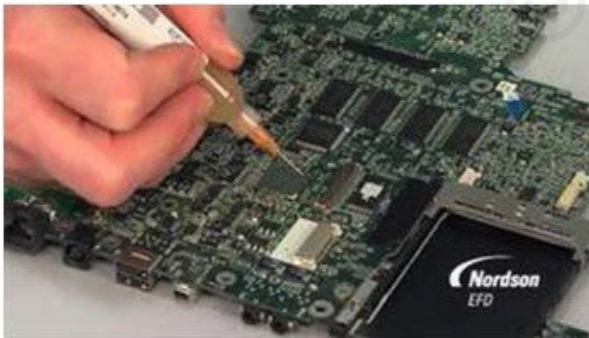

- 3 Adjust and set the temperature and apply the hot air over the SMD - IC to be removed as shown in Fig 3

Fig 3



- 4 Slowly try to insert the tweezers to lift from one side and remove the SMD - IC from the PCB as shown in Fig 4

Fig 4



- 5 Take away the SMD - IC using tweezers as shown in Fig 5

Fig 5



- 6 Remove any excess solder over the pads using solder wick as shown in Fig 6

Fig 6



- 7 Clean the solder pads using IPA solution with cotton buds/brush as shown in Fig 7
- 8 Check the pad of the SMD - IC using magnifier lens is cleaned.

Fig 7



- 9 Verify no pad is damaged as shown in Fig 8
- 10 Get the work checked by the Instructor.

Fig 8



### TASK 3: Removal of SMD components using desoldering pump

- 1 Collect the defective SMD circuit board from the Instructor and identify the components to be removed.
- 2 Inspect the size of the solder joints on the component to be removed using magnifying glass.

**Note: If the size of the solder joint is small apply additional solder to form an excess solder joint.**

- 3 Apply a small quantity of the flux to the solder joint of the component to be removed.
- 4 Use the Vacuum desoldering tool as shown in Fig 1 and align the desoldering tool tip contact the solder joint.

Fig 1



- 5 Place the soldering iron tip on the joint to melt solder.
- 6 Activate the Vacuum bulb immediately to extract the molten solder completely from the joint as shown in Fig 2

Fig 2

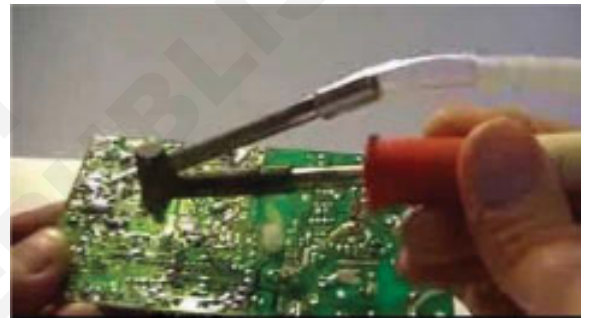

- 7 Remove the desoldering tool tip and then turn OFF the Vacuum pump.

**Note: To avoid thermal build up on the adjacent components, desolder the joints alternatively.**

- 8 Use tweezers to remove the SMD component from the PCB and clean the surface using cleaning solution.
- 9 Get the work checked by the Instructor.
- 10 Pad of SMD - IC removes check the cleaner are using magnifier lens.
- 11 Get the work checked by the Instructor.

**Check and repair PCBs single, double layer and important test for PCBs**

**Objectives :** At the end of this exercise you shall be able to

- identify the single and double layer PCB
- check the possible faults in the PCB
- repair the identified defect crack in the PCB/track on the PCB.

<b>Requirements</b>			
<b>Tools/Equipments/Instruments</b>		<b>Materials/Components</b>	
• Trainees tool kit	- 1 Set.	• Rosin cored solder	- as reqd.
• Magnifier with lamp	- 1 No.	• IPA cleaning solution	- as reqd.
• ESD table/surface with wrist strap	- 1 No.	• Solder flux pen/liquid flux	- as reqd.
• Soldering workstation/hot air temperature/flow controller (with instruction manual)	- 1 Set.	• Cleaning brush	- 1 No.
• Watchmaker's screw driver	- 1 Set.	• Cotton swab/wipes	- as reqd.
• Digital multimeter with probes	- 1 No.	• Epoxy tube	- as reqd.
• PCB repair kit with bonding tip, bonding system	- 1 Set.	• Emery cloth / paper	- 1 No.
• Small 'C' / 'G' clamp	- 1 No.	• Kapton tape	- 1 No.
		• Adhesive bonding tape	- 1 No.
		• Single/double layer PCB	- 1 No.

**PROCEDURE**

**TASK 1: Checking the single and double layer PCB**

- 1 Collect the required materials from the Instructor.
- 2 Identify the single and double layer PCB.
- 3 Physically check the PCB for any damage.
- 4 Use magnifying glass and observe for crack in any of the tracks on the PCB.
- 5 Record the observations in the Table 1.

**Table 1**

<b>Sl.No</b>	<b>Types of PCB Single/Double layer</b>	<b>Physical damages noticed Crack on track</b>	<b>Crack on PCB</b>	<b>Remarks</b>

**TASK 2: Repair the identified defect in the single/double layer PCB**

**Note:**

- 1 Mix the epoxy as per the manufacturer's instruction to use on the PCB.
- 2 Arrange a vibration free space to keep the PCB for the setting time

- 1 Apply a little quantity of epoxy on both the cracked portions of PCB (avoid excessive quantity of epoxy).
- 2 Hold the two sides of the cracked PCB pressed together.
- 3 Keep the PCB for 15 to 30 seconds time for setting without any shake.



**Note: Allow 30 minutes setting time for the PCB before proceeding to the next step.**

- 4 Follow the above steps for double sided PCB also.
- 5 Get the work checked by the Instructor.

---

### TASK 3: Repair the cracked track on the PCB

- 1 Scrape both sides on the cracked track and clean the surface.
- 2 Use soldering iron and tin both the sides on the cracked track as shown in Fig 1.

Fig 1

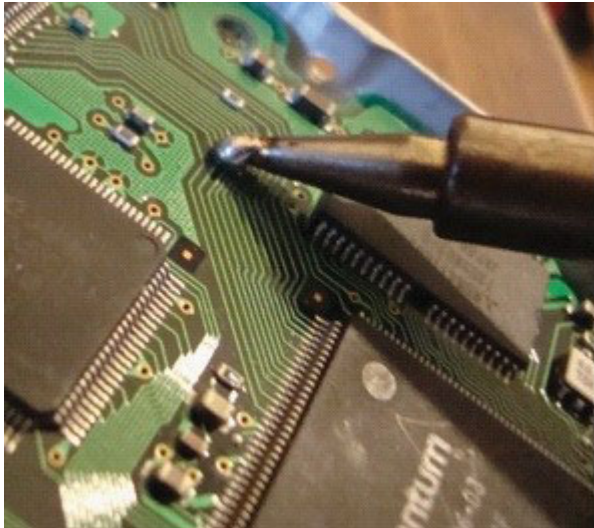

- 3 Select a small piece of a thin wire suitable to the width of the track.

- 4 Use tweezers, tin the wire piece and position correctly bridging over the crack as shown in Fig 2.

Fig 2

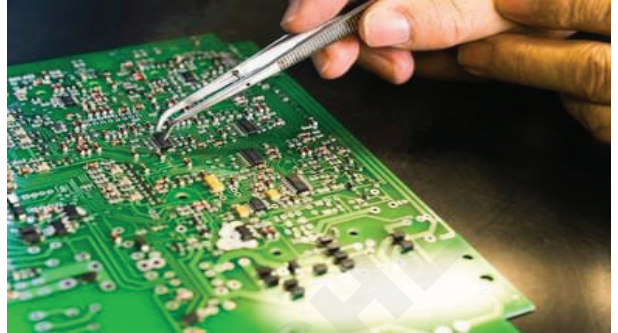

- 5 Solder the tinned copper wire piece over the track completely covering the crack.
- 6 Use magnifying glass and check for any solder bridge around the repair area.
- 7 Check the continuity of the repaired track using Ohm meter.
- 8 Get the work checked by the Instructor.

**Inspect soldered joints, detect the defects and test the PCB for rework**

**Objectives :** At the end of this exercise you shall be able to

- inspect the soldered joint for any defects
- detect the type of defect in the soldered joint
- test the given PCB for rework.

<b>Requirements</b>			
<b>Tools/Equipments/Instruments/Raw materials</b>		<b>Materials/Components</b>	
• Trainees tool kit	- 1 Set	• IPA Solution	- 1 bottle
• Magnifier with lamp	- 1 No.	• Cleaning Brush	- 1 No.
• Soldering Iron 25W/ 240 VAC	- 1 No.	• Cleaning Cloth	- as reqd.
• Safety glass/ goggles	- 1 No.		
<b>AIDS: Chart showing images on different types soldering defects in the PCB assemblies using electronic component</b>			
	-1 No.		

**PRODECURE**

**TASK 1: Inspection of the soldered joints**

**Note: The Instructor has to show some samples of PCB with defective soldered joints and explain to the trainees.**

- 1 Collect the defective PCB for the inspection.
- 2 Make visual inspection on the board for any physical damage/defect.
- 3 Clean the residual flux on the solder joint using IPA solution with brush.
- 4 Use magnifier with bright white light, carefully observe the shape of the joint formation, surface texture, mechanical bonding and any brown wax like material.
- 5 Refer to the Chart - 1 showing types of defects on the soldered PCB.

**Chart - 1**

**Chart showing various types of soldered joint defects**

SI.No.	Name of the defect	Visual Observation	Remarks
1	Dry Joint / Cracked joint/Lifted Component		
2	Poor solder joint/ Cracked joint/Lifted Component		
3	Excess solder on joints		
4	Wetting defects/ Pin or blow holes		
5	Temperature defects/ overheating		
6	Lumps of charred flux.		

6 Record the detected/ observed defect on the Table-1.

**Table 1**

7 Get the work checked by the Instructor and record the remarks for rework on the PCB.

SI.No.	Observation on the soldered joint	Name of the defect	Remarks

## TASK 2 : Removal of through hole solder joint using vacuum desoldering tool

- 1 Collect the defective board from the Instructor and identify the component to be removed.
- 2 Inspect the size of the solder joints on the component to be removed using magnifying glass as shown in Fig 1, 2 & 3.

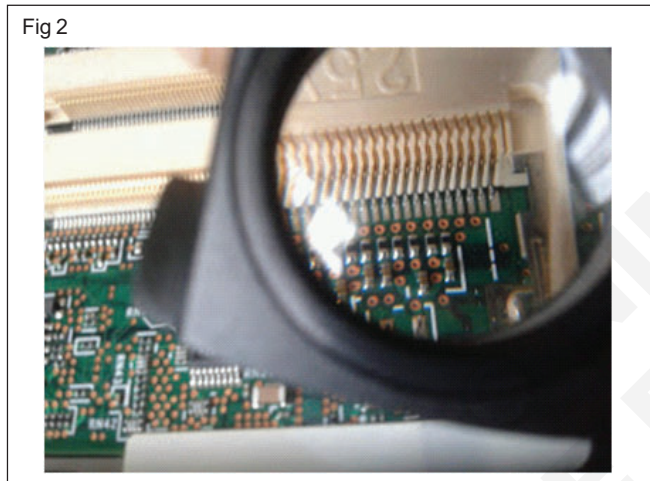
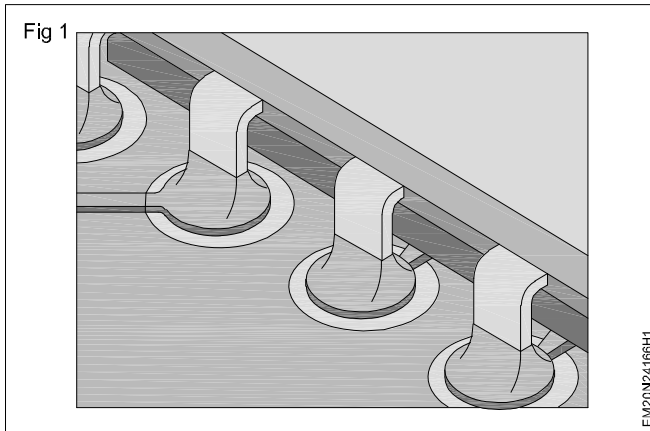

- 3 If the sizes of the solder joints are minimal, apply additional solder to form an "excess solder" joint as shown in Fig 4.

Fig 4

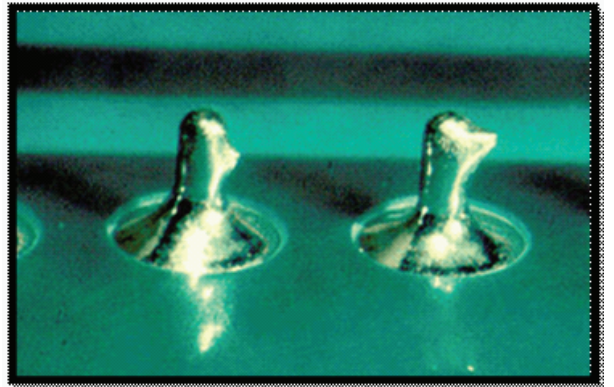

- 4 Apply a small amount of flux to the solder joints of the component to be removed.
- 5 Take the vacuum desoldering tool as shown in Fig 5 and align the desolder tip with a component lead end and lightly make contact with the solder joint.

Fig 5



Keep the desolder tip off the pad by allowing it to slide around on a film of solder as shown in Fig 6 & 7.

**Caution : Do not apply pressure with the solder extractor tip to the leads or other conductive patterns.**

**Wear Safety Glass. The molten solder may hit the eye.**

Fig 6

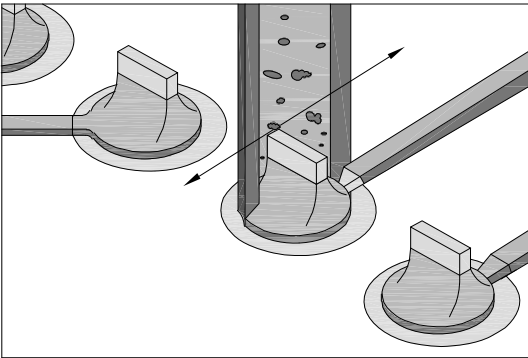

EM20N24166H6

Fig 7

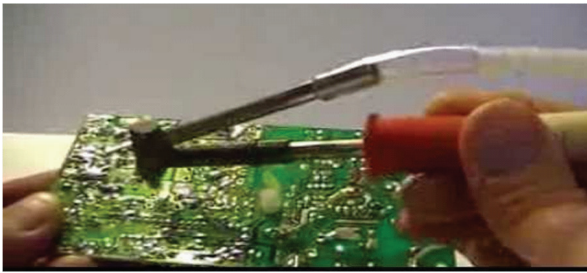

6 After the solder has melted, start a rotating or oscillating motion with the desolder tip. Continue the rotating motion until a change in the "feel" of the rotating motion occurs as shown in Fig 8 & 9.

Fig 8

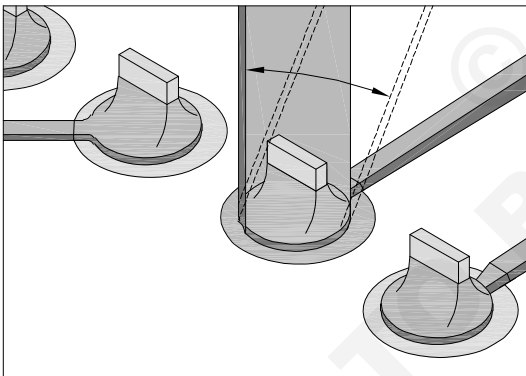

EM20N24166H8

Fig 9

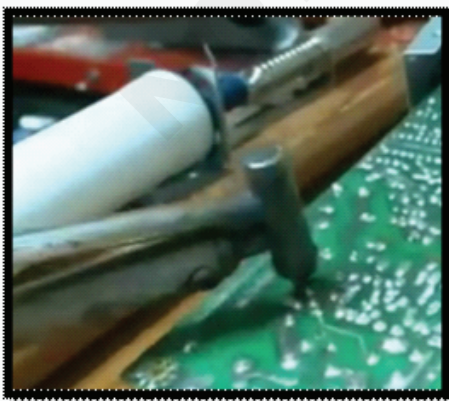

7 When the solder in the solder joint is completely molten, immediately activate the vacuum tool extracting the solder from the solder joint as shown in Fig 10 & 11.

**Maintain rotation of the desolder tip while continuous vacuum is being applied. This allows air to cool both the component lead and the plated-through hole.**

Fig 10

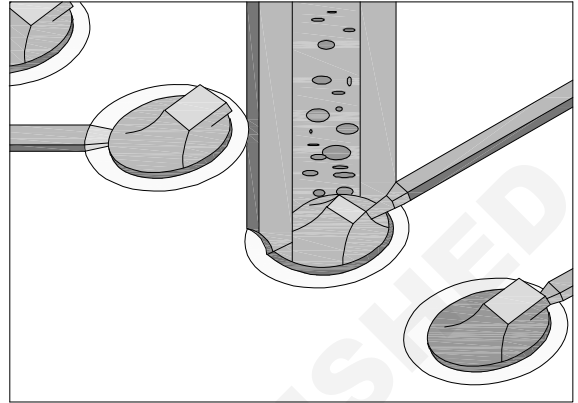

EM20N24166HA

Fig 11

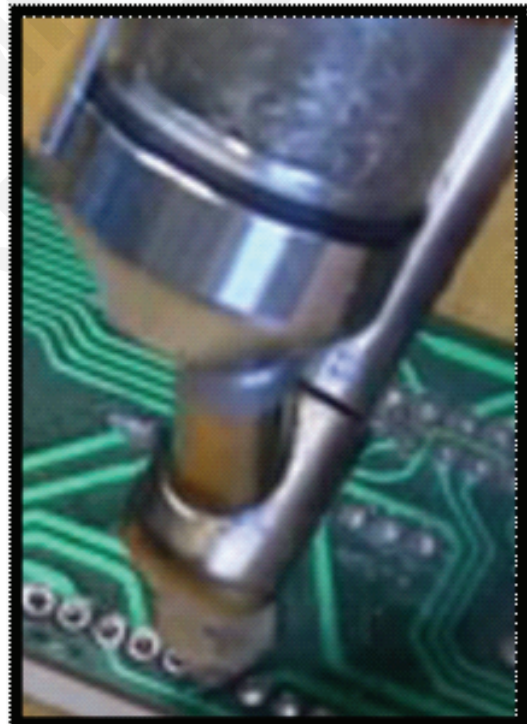

8 After the solder has been extracted from the solder joint, remove the desolder tip from the component lead.

9 Maintain continuous vacuum for a few seconds to clear the desolder tip.

10 Turn off the vacuum.

11 Use a flat nose pliers to gently rotate the lead laterally break any remaining solder joints as shown in Fig 12.

12 Desolder each of the remaining component leads individually using a skipping method to reduce thermal buildup at adjacent hole locations.

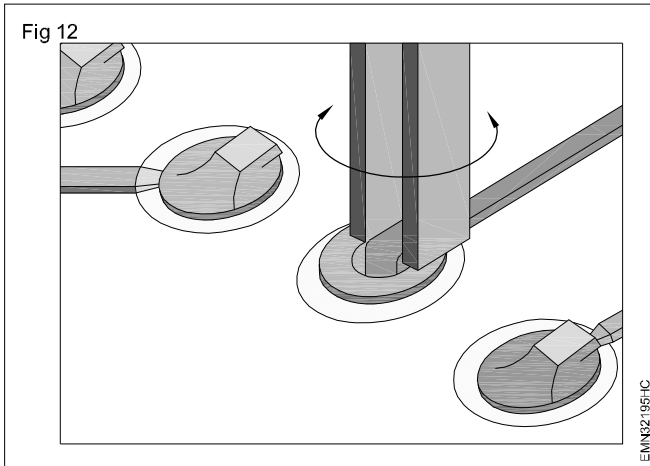

13 Check each component lead that they are not soldered to the side of the plated hole as shown in Fig. 13 and then remove component using tweezers.

**Note: If each lead is not completely free, resolder the joint and repeat steps 2 - 12.**

14 Clean the surface using cleaning solution and get the work checked by the Instructor.

Fig 13

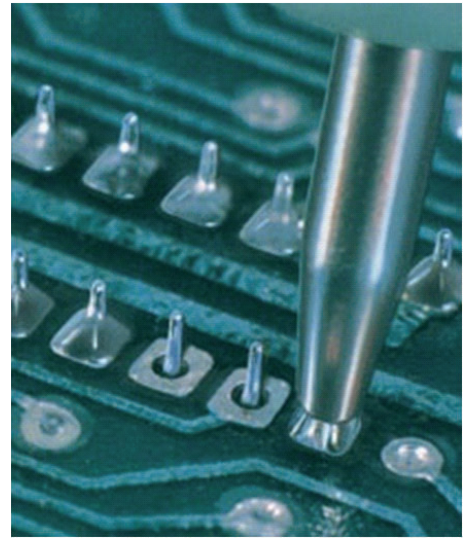

15 Practice this process to remove few more components

16 Get the work checked by Instructor.

### TASK 3 : Test the given PCB rework

Specific steps for circuit board for repairing

Step 1 : Remove the damaged components or pads.

Step 2 : Clean tracks and remove solder.

Step 3 : Put the copper tape on the track.

Step 4 : Welded joints.

Step 5 : Recovery the PCB vias.

Step 6 : Place and solder your components.

Step 7 : Trim excess tape from repaired area.

Fig 1

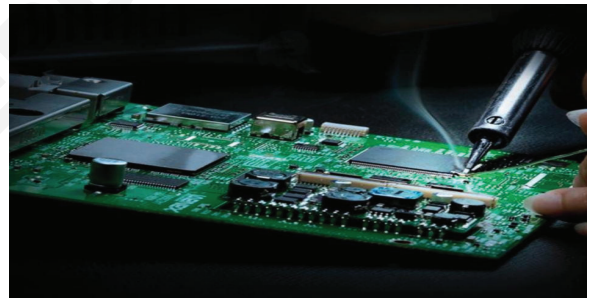

**Identify different types of fuses along with fuse holders, over load relay, (no volt coil) current adjust bimetallic strips to set the current**

**Objectives :** At the end of this exercise you shall be able to

- identify different fuses and fuse holders
- identify the bimetallic type overload relay parts to adjust the tripping current.

<b>Requirements</b>	
<p><b>Tools/Equipments/Instruments</b></p> <ul style="list-style-type: none"> <li>• Trainees tool kit - 1 Set.</li> <li>• Digital/multimeter with probes - 1 No.</li> </ul> <p><b>Aids: Chart showing all types of fuses and fuse holders along with their uses/application</b> - 1 No.</p>	<p><b>Materials/Components</b></p> <p><b>Different types of fuses:</b></p> <ul style="list-style-type: none"> <li>• Kit kat, glass cartridge type open and closed types - as reqd.</li> <li>• Ferrule contact type - as reqd.</li> <li>• HRC fuse - as reqd.</li> <li>• Diazed screw type - as reqd.</li> <li>• Blade fuse - as reqd.</li> </ul>

**PROCEDURE**

**TASK 1: Identification of fuses and fuse holders**

**Note:**

- 1 The Instructor has to demonstrate all types of fuses and fuse holders with their uses/ application**
- 2 Label the fuses and fuse holders separately with suitable code numbers**

1 Pick any one of the fuses from the lot.

- 2 Refer to the Chart 1, identify the type of fuse and note down the coding for the type /rating etc.
- 3 Record the observations in Table 1.
- 4 Pick one of the fuse holder and repeat above steps.
- 5 Follow steps 1 to 4 for all the remaining fuses and fuse holders, record the observations.
- 6 Get the work checked by the Instructor.

**Table 1**

SI.No	Label with Alphabet	Name of the type		Rating in Amps	Application
		Fuses	Fuse Holder		
1	A				
2	B				
3	C				
4	D				
5	E				
6	F				
7	G				
8	H				
9	I				
10	J				

**TASK 2: Identification of bimetallic type thermal overload relay**

- 1 Collect the thermal overload relay from the Instructor along with the instruction leaflet (Example given in Fig 1).
- 2 Refer to the instruction manual and identify the make/manufacturer/model no/parts and controls on the thermal overload relay.
- 3 Identify the load current adjustment setting and markings on the dial.
- 4 Record the observations in Table 2.
- 5 Use Ohm meter and identify/check the Normally Open and Closed contacts.
- 6 Measure the no-volt coil resistance and note down the observed value in Table 3.

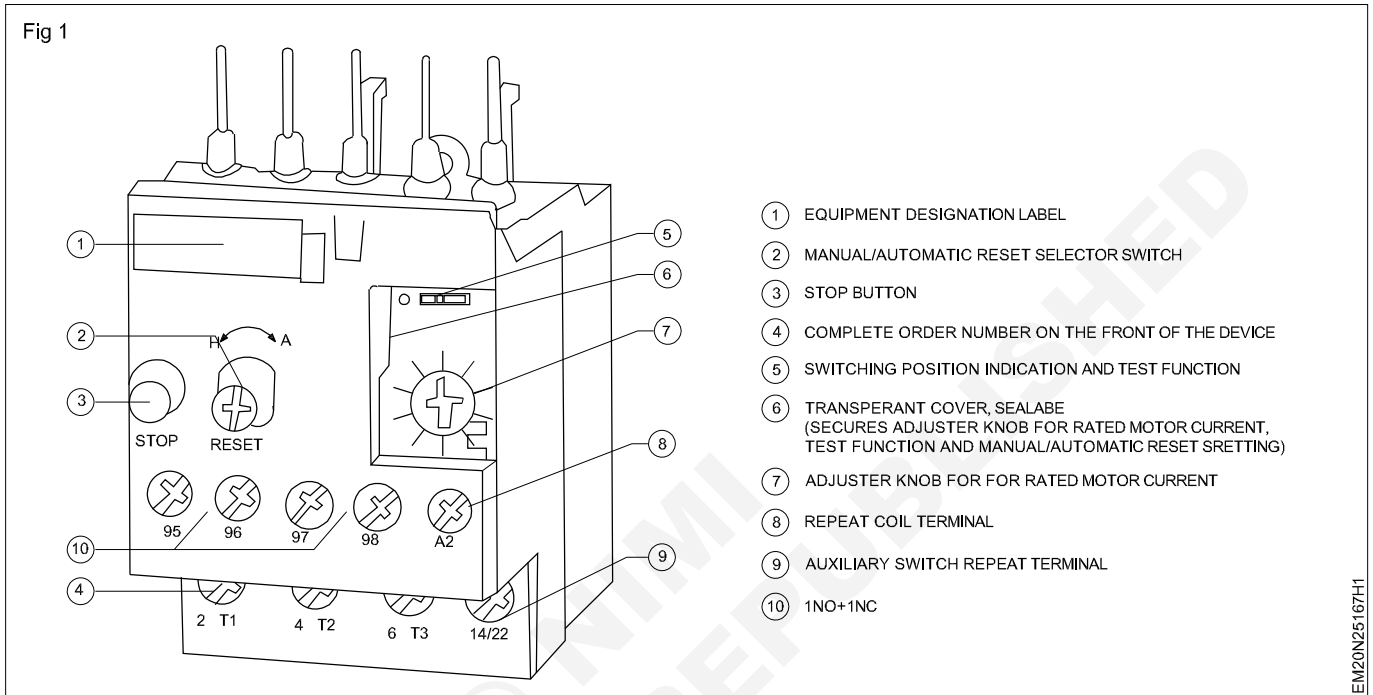

**Table 2**

SI.No.	Name of the part Control/Switch	Description	Remarks

**Table 3**

SI.No.	Identified item/terminal	Description/colour code/code Numbers	Remarks
1	Normally open contact		
2	Normally closed contact		
3	No volt coil resistance		
4	Minimum current adjustment		
5	maximum current adjustment		
6	Trip time in seconds as per the manufacturer		

**Test the given MCBs**

**Objectives :** At the end of this exercise you shall be able to

- identify the terminals of MCB
- connect the MCB in an electrical circuit
- check the operation of MCB and ensure its function.

**Requirements**

**Tools/Equipments/Instruments**

- |   |         |                                      |            |
|---|---------|--------------------------------------|------------|
| • Trainees tools kit                            | - 1 No. | • Single phase motor 1 HP, 240V/50Hz | - 1 No.    |
| • Combination plier 150 mm                      | - 1 No. | • MI Ammeter (0-10A)                 | - 3 Nos.   |
| • Screw driver 150 mm                           | - 1 No. | • Connecting wires                   | - as reqd. |
| • Electrician knife 100 mm                      | - 1 No. | • SPDT switch 240V/6A                | - 1 No.    |
| • Miniature circuit breaker single pole 240V/6A | - 1 No. | • MCB (3P + N) 415V/6A               | - 1 No.    |
|   |         | • Three phase lamp load              | - 1 No.    |

**PROCEDURE**

**TASK 1: Identify the terminals of the MCB**

- 1 Identify the supply and load terminals of a single pole MCB referring to the actual given MCB . (Fig 1).
- 2 Check the continuity between source and load terminals to ascertain healthiness of MCB.

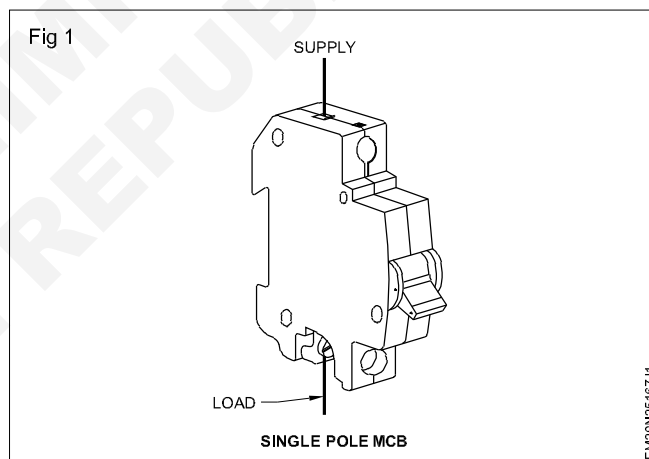

**TASK 2: Connect a single pole MCB to the load and test it**

- 1 Collect the miniature circuit breaker and read the specification of given MCB.
- 2 Connect the circuit elements as per the circuit diagram shown in Fig 1.
- 3 Keep the MCB in ON condition (up) and switch ON the main power supply.
- 4 Close the SPT switch  $S_1$  and operate the single phase motor with load.
- 5 Operate the motor and note down the reading of the ammeter in Table 1.
- 6 Increase the motor load, till the MCB trips.
- 7 Note down the value of current at which the circuit breaker trips in the circuit.
- 8 Check whether the MCB trips at  $1.3 \times I_n$  where  $I_n$  is the normal rated current of the MCB.

**Table 1**

Sl.No	Load current	MCB Status
1	0.5 A	ON
2	1.0 A	ON
3		
4		
5		
6		



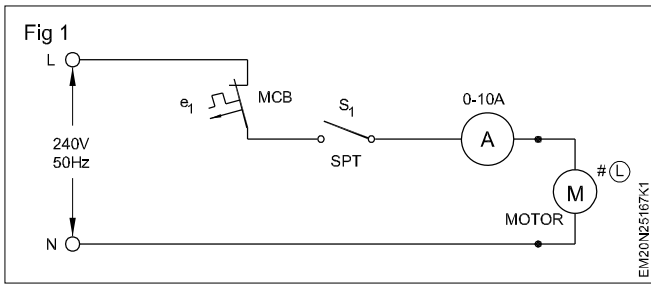

**TASK 3: Connect a 4 pole MCB to the load and test it.**

- 1 Collect the 4 pole MCB and read its specifications
- 2 Identify the supply and load Terminal connection of a four pole MCB by referring the Fig 1.

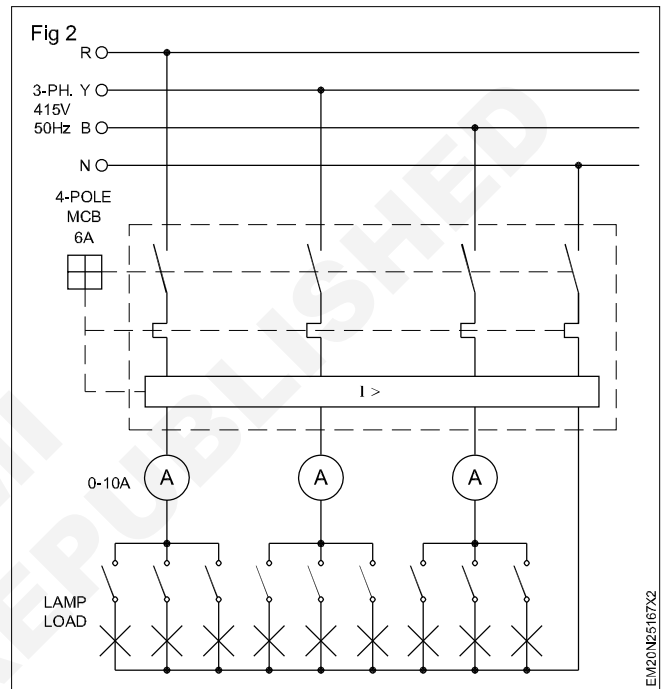
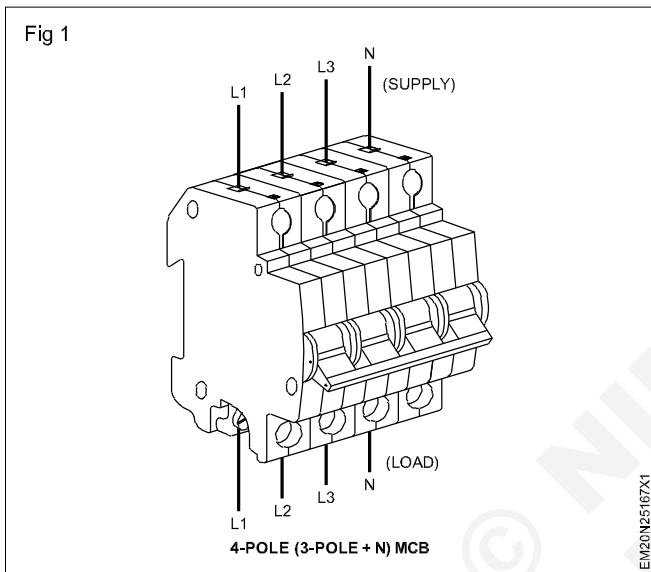

- 3 Complete the circuit, as shown in circuit diagram (Fig 2).
- 4 Keep the MCB in ON position and switch ON the mains supply.
- 5 Switch on the lamp load step by step and note down the readings of the ammeter in the Table 2

**While switching the load check that the load on each phase should be equal.**

- 6 Increase the load current in steps of 0.5 amp and observe the MCB till it trips off.
- 7 Note down the current at which the MCB trips off.

**Table 2**

Sl. No	Load current	MCB Status
1	0.5 A	ON
2	1.0 A	ON
3		
4		
5		
6		

**Connect an ELCB and test the leakage of an electrical motor control circuit**

**Objectives:** At the end of this exercise you shall be able to

- identify the terminals of ELCB
- connect the ELCB in an electrical circuit and test its functioning
- measure the leakage current at which ELCB trips off.

Requirements	
Tools/Instruments/Equipments	Materials/Components
<ul style="list-style-type: none"> <li>• Trainees tool kit - 1 No.</li> <li>• Cutting plier 150mm - 1 No.</li> <li>• Screw driver 150mm - 1 No.</li> <li>• Electrician knife 100mm - 1 No.</li> <li>• Wire stripper 150 mm - 1 No.</li> <li>• Ammeter MI (0 - 10A) - 1 No.</li> <li>• Ammeter MI (0 - 100mA) - 1 No.</li> </ul>	<ul style="list-style-type: none"> <li>• ELCB 240V/25A, 2 pole with Tripping leakage current 30mA - 1 No.</li> <li>• MCB 240V/10A, 2 pole - 1 No.</li> <li>• 10kΩ 1W wire wound variable resistor - 1 No.</li> <li>• 5kΩ 1W fixed resistor - 1 No.</li> <li>• Pushbutton switch 240V, 6A - 1 No.</li> <li>• Water rheostat - 1 No.</li> </ul>

**PROCEDURE**

**TASK 1: Identify the terminals of ELCB**

- 1 Collect the ELCB, read the specification given on it and record them in Table 1.
- 2 Identify the supply terminals and load terminals referring to marking on the unit as given in Fig 1.
- 3 Check the continuity between source and load terminals by actuating manually.

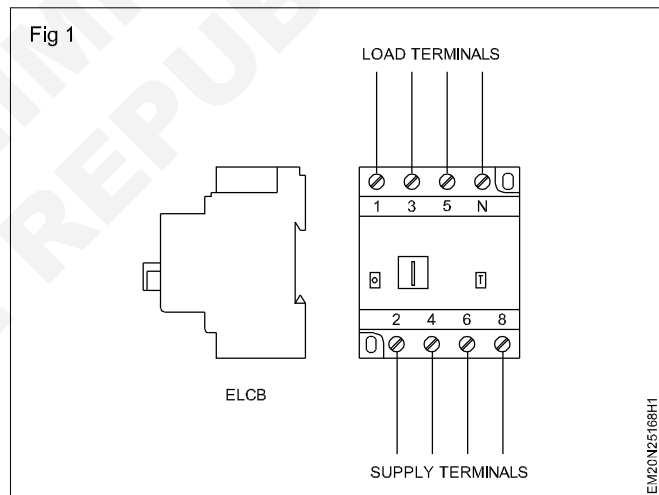

**TASK 2: Connect and test the operation of ELCB**

- 1 Wire up the circuit as shown in the circuit diagram (Fig 1).
- 2 Switch on the main supply keeping the MCB and ELCB in ON position.
- 3 Close switch  $S_1$  and operate the water rheostat till the ammeter 'A' reads about 5 A current.
- 4 Press the test switch and vary the variable resistance and note the leakage current and record in Table 1.
- 5 Record the leakage current at which the ELCB trips off in Table 1.
- 6 Open the external test switch and reset the ELCB.
- 7 Test ELCB for 'Trip function' by operating the 'Test button'. In this case the ELCB must trip off when the button is pressed.

**Keep variable resistance 'Rs' in full cut in position.**

**TASK 3 : Measure the leakage current at which ELCB trips off**

**Table 1**

Sl.No.	Leakage current in mA	ELCB Status
1	5	ON
2	10	ON
3		
4		
5		

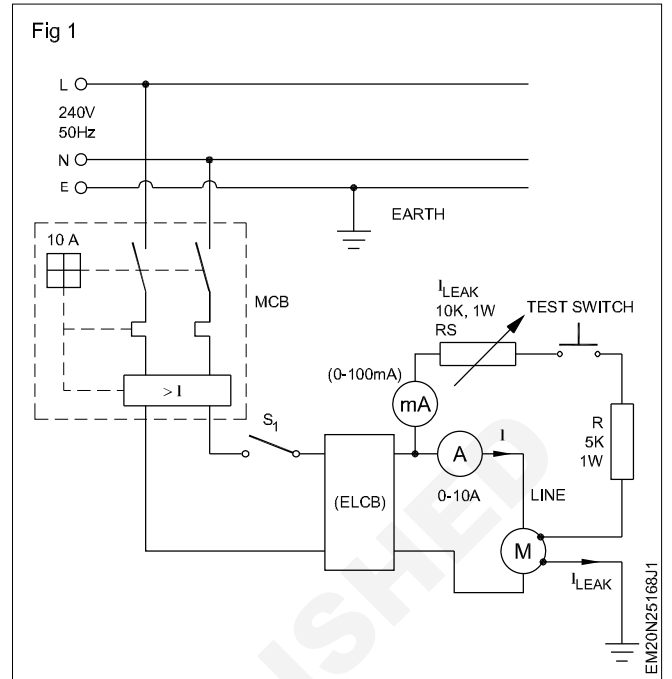

© NIMI  
NOT TO BE REPRODUCED

**Test DC motor and its operating voltage**

**Objectives:** At the end of this exercise you shall be able to

- test low voltage DC motor by measuring its operating voltage and reverse its direction of rotation.

Requirements	
<b>Tools/Instruments/Equipments</b> <ul style="list-style-type: none"> <li>• DC Ammeter (0-500 mA)</li> <li>• DC voltmeter (0-15V)</li> <li>• SPST switch (1A)</li> <li>• Hookup wire</li> </ul>	<b>Materials/Components</b> <ul style="list-style-type: none"> <li>• RPS / 9V battery</li> <li>• Low voltage DC Motor</li> </ul>
<ul style="list-style-type: none"> <li>- 1 No.</li> <li>- 1 No.</li> <li>- 1 No.</li> <li>- as reqd.</li> </ul>	<ul style="list-style-type: none"> <li>- 1 No.</li> <li>- 1 No.</li> </ul>

**PROCEDURE**

- 1 Collect all the required components from instructor and check its working condition.
- 2 Construct the circuit as shown in Fig 1.

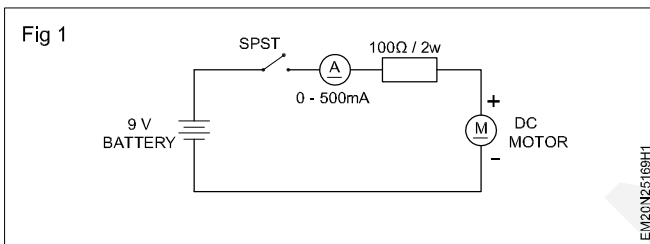

- 3 Switch ON the power Supply
- 4 Press switch K and observe the motor current, motor voltage, direction of rotation and tabulate it (Table 1)

- 5 Switch OFF the power supply
- 6 Reverse the polarity of motor terminal as shown in Fig 2.
- 7 Repeat the step 3, 4 and tabulate the observed readings
- 8 Get the work checked by the instructor

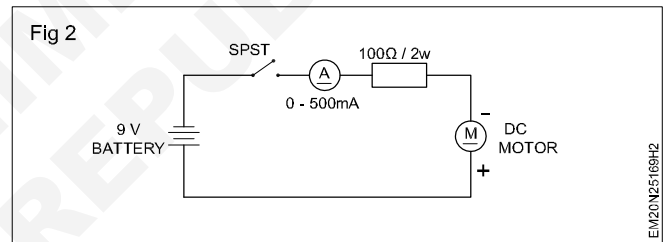

**Table 1**

S.No	Direction of Rotation	Forward Motor Current	Forward Motor Voltage

Test DC motor control signal

**Objectives:** At the end of this exercise you shall be able to  
 • test and control speed of DC Motor using PWM technique.

Requirements	
<b>Tools/Instruments/Equipments</b>	
• Digital Tachometer / Stroboscope	- 1 No.
• DC RPS (0-30V / 2A)	- 1 No.
• DMM with probes	- 1 No.
<b>Materials/Components</b>	
• IC 555	- 1 No.
• Low voltage DC Motor	- 1 No.
• Resistor 1kΩ / ½w	- 1 No.
• Resistor 10kΩ / ½w	- 2 Nos.
• Potentiometer 100kΩ	- 1 No.
• Diode IN4007	- 3 Nos.
• capacitor (1μF, 0.1μF/25v)	- 1 No each.
• Transistor 2N3055	- 1 No.

PROCEDURE

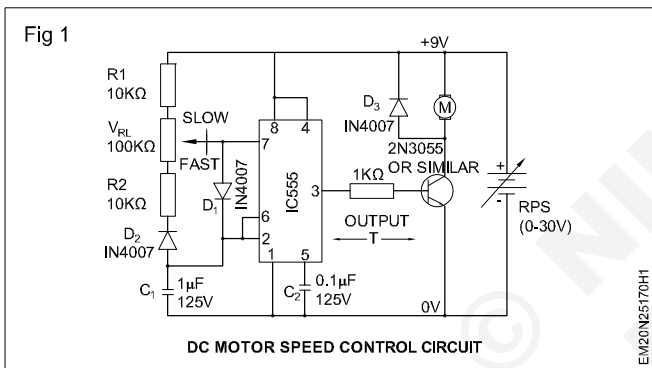

- 1 Collect and check the working condition of all the given components by multimeter
- 2 As shown in Fig1, construct PWM circuit using IC 555 and connect the

- 3 Connect the motor to the circuit as per connection diagram
- 4 Switch ON the RPS power supply
- 5 Select DC low volt range in multimeter
- 6 Use multimeter / CRO. connect the +ve probe to IC 555 Pin No : 3 and connect -ve probe to ground terminal.
- 7 Observe the direction of rotation and speed of DC motor during PWM pulse ON/OFF condition and tabulate the reading in Table 1.
- 8 Adjust the POT  $V_{R1}$  and repeat step 4,5,6,7
- 9 Get the work checked by instructor.

Table 1

Sl. No.	Output pulse ON/OFF Condition	DC Motor speed condition (Slow/Fast)	RPM Value
1	Pulse ON condition	_____	_____
2	Pulse OFF condition	_____	_____

Test various low potential motors

Objectives: At the end of this exercise you shall be able to

- test low voltage DC servo motor by changing its direction of rotation.

Requirements		
<b>Tools/Instruments/Equipments</b>		
• DC RPS (0-30v/2A)	- 1 No.	• Resistor (220Ω, 10kΩ, 36kΩ, 68kΩ/1/2w)
• DMM with probes	- 1 No.	
• Low voltage DC servo motor	- 1 No.	• Transistor BC547
• CRO/DSO	- 1 No.	• Capacitor (10nF, 100nF/25V)
<b>Materials/Components</b>		• Push button (No type)
• IC 555	- 1 No.	

PROCEDURE

- 1 Collect and check the working condition of all the given components by multimeter
- 2 As shown in Fig 1, construct the servo motor driver circuit

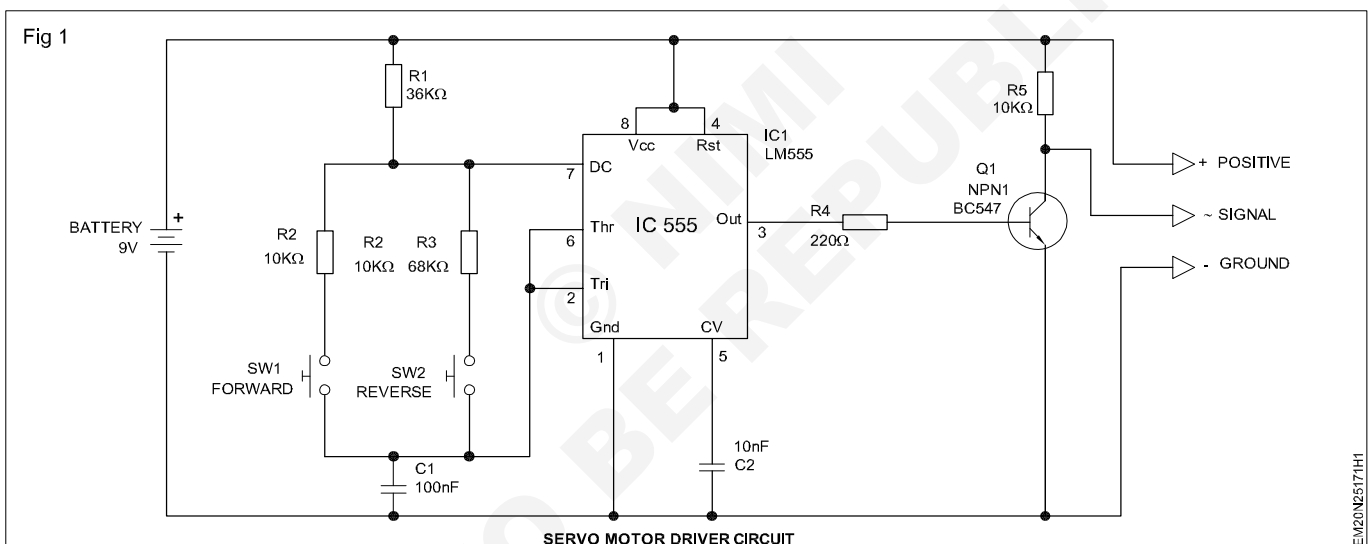

- 3 Connect the +ve terminal of servo motor (Red wire) to +ve terminal of power supply similarly connect the -ve terminal of servo motor (Black/Brown wire) to -ve terminal of power supply.
- 4 Connect the servo motor signal wire (Orange/Yellow wire) to driver circuit output terminal.
- 5 Now switch ON the power supply. Press Forward Switch  $S_1$  and observe the direction of rotation of motor and tabulate in Table-1.
- 6 Now press reverse switch  $S_2$  and repeat step 5
- 7 Connect CRO +ve probe in driver circuit output Terminal and CRO -ve probe in ground terminal.
- 8 observe output pulse time period as per motor direction and calculate the duty cycle and tabulate in table - 1.
- 9 Get the work checked by instructor.

Table 1

Sl. No.	Switch Condition	Motor direction (Forward/Reverse)	Pulse ON Time	Pulse Total Time(ON+OFF) Time	Duty Cycle (ON Time/Total Time)
1	Forward Switch $S_1$				
2	Reverse Switch $S_2$				

### Test stepper motors

**Objectives:** At the end of this exercise you shall be able to  
 • test the given stepper motor using multimeter

Requirements			
Tools/Instruments/Equipments			
• Stepper motor	- 1 No.	• Datasheet	- 1 No.
• Multimeter with probe	- 1 No.		

### PROCEDURE

#### TASK 1: Test the given stepper motor using multimeter

1 Find and test the colours of the wires in the given stepper motor (Fig 1)

**5 or 6 colour wires are available**



- 2 Common wire us shorted.
- 3 Stepper motor consists four number of coils that is coil 1, coil 2, coil 3 and coil 4 and observe the coils.
- 4 Take the multimeter for testing as shown in Fig 2.

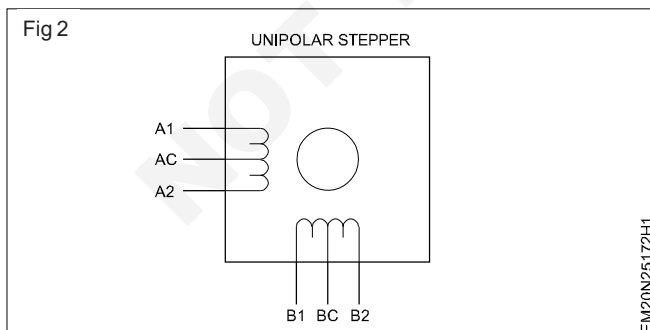

- 5 In multimeter fix the resistance mode in 20kΩ
- 6 Use multimeter, In two series coils Resistance available 0.16Ω and test in centre, resistance available in 0.8Ω
- 7 Use multimeter Test the terminals of stepper motor (Fig 3).
- 8 Next connect the power supply unit and check the 12.
- 9 Confirm the stepper motor us working or not.

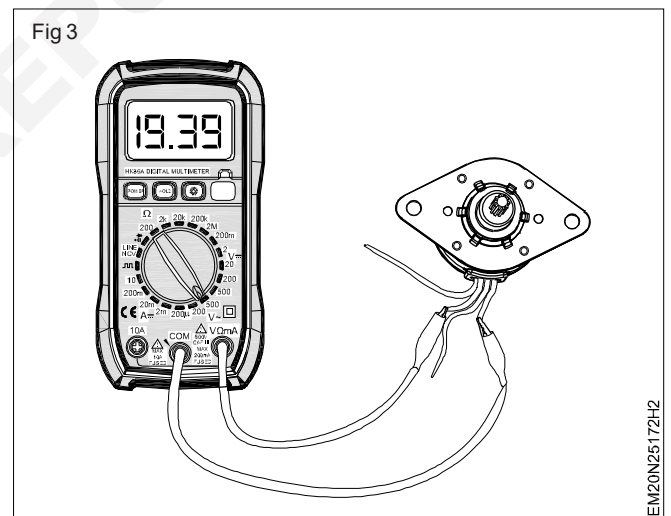

EM20N25172H2

**Demonstrate working process of stepper motor in various equipments**

**Objectives:** At the end of this exercise you shall be able to

- identify the types of stepper motor used in various equipments.

<b>Requirements</b>			
<b>Tools/Instruments/Equipments</b>			
• Trainees Tool kit	- 1 No.	• DMM	- 1 No.
• Different type of equipments such as 3D printer/Robotical flop disc drive/ DOT matrix printer drive, etc.	- 1 No each.		

**PROCEDURE**

**TASK 1: Identification and testing of stepper motor type**

- 1 Pick any one of the equipment given by your instructor.
- 2 Remove the stepper motor.
- 3 Test the stepper motor type.
- 4 Tabulate the type of stepper motor
- 5 Repeat the above steps for remaining equipments.
- 6 Get the work checked by your instructor.

**Table 1**

<b>S.No</b>	<b>Type of the equipment</b>	<b>Type of the stepper motor used</b>	<b>Specification</b>
1			
2			
3			
4			



**Modulate and demodulate various signals using AM and FM on the trainer kit and observe waveforms**

- Objectives :** At the end of this exercise you shall be able to
- modulate the amplitude of audio signal using trainer kit
  - demodulate the AM signal and measure the waveforms
  - modulate and demodulate of audio signal.

Requirements		
<b>Tools/Equipments/Instruments</b>		
• Trainees tool kit	- 1 Set.	• CRO-20 MHz-Dual trace with probe kit & instruction manual - 1 Set.
• DMM with probes	- 1 No.	
• AM/FM trainer kit with instruction manual and patch cards	- 1 Set.	

**PROCEDURE**

**Note: The instructor has to check and verify the output signal of the built in audio generator terminal and also the carrier wave generator on the AM trainer kit.**

**TASK 1 : Amplitude modulation of audio signal**

- 1 Collect the AM trainer kit and identify the signal input - output terminals.
- 2 Prepare the CRO for measurement and connect the channel-1 with the direct probes.
- 3 Switch ON the AM trainer kit, connect the output of audio generator to channel -1 of CRO and measure the output signal waveform; calculate frequency of audio generator.
- 4 Repeat the step-3 for carrier wave generator.
- 7 Connect the output signal of the AM modulator to the CRO and measure the modulated waveform/frequency.
- 8 Record the observations in Table-2.
- 9 Get the work checked by the Instructor.

**Table-1 A**

SI.No	Audio signal	
1	Waveform	
2	Amplitude	
3	Frequency	

**Table-1 B**

SI.No	Carrier wave signal	
1	Waveform	
2	Amplitude	
3	Frequency	

**Table-2**

SI.No	AM Modulator output	
1	Waveform	
2	Amplitude	

- 5 Record the observations in Table 1A and 1B.
- 6 Use patch card, connect the output of audio generator to the input of AM modulator section.

**TASK 2 : Demodulation of AM signal**

- 1 Identify the input and output terminals of the demodulator (detector) circuit.
- 2 Use patch cord and connect the output signal from AM modulator section to the input of AM Demodulator section.

- 3 Connect the output of AM demodulator to the Channel -1 of CRO input.
- 4 Switch ON the set up and measure the waveform at the input/output of demodulator circuit.
- 5 Record the observations in Table -3

**Table - 3**

Sl.No	Demodulated signal	
	Input waveform	Output waveform
1		

**TASK 3: Frequency modulation and demodulation of audio signal**

- 1 Identify the input and output terminals of FM modulator section on the trainer kit.
- 2 Use patch cord, connect the output of audio signal and carrier signals to the input of FM modulator section.
- 3 Switch ON the set-up, prepare the CRO for measurement and connect the ch-1 input to the FM modulator section output.
- 4 Measure the waveform, calculate the amplitude and record the observations in Table-4.
- 5 Connect the output of FM modulator section to the input of FM demodulator section.
- 6 Switch ON the setup and measure the input / output of FM demodulator circuit.

- 7 Record the observations in the Table-4.

**Table - 4**

Sl. No.	Parameter	FM Modulator Output	FM demodulator Output
1	Waveform		
2	Amplitude		

- 8 Get the work checked by the Instructor.

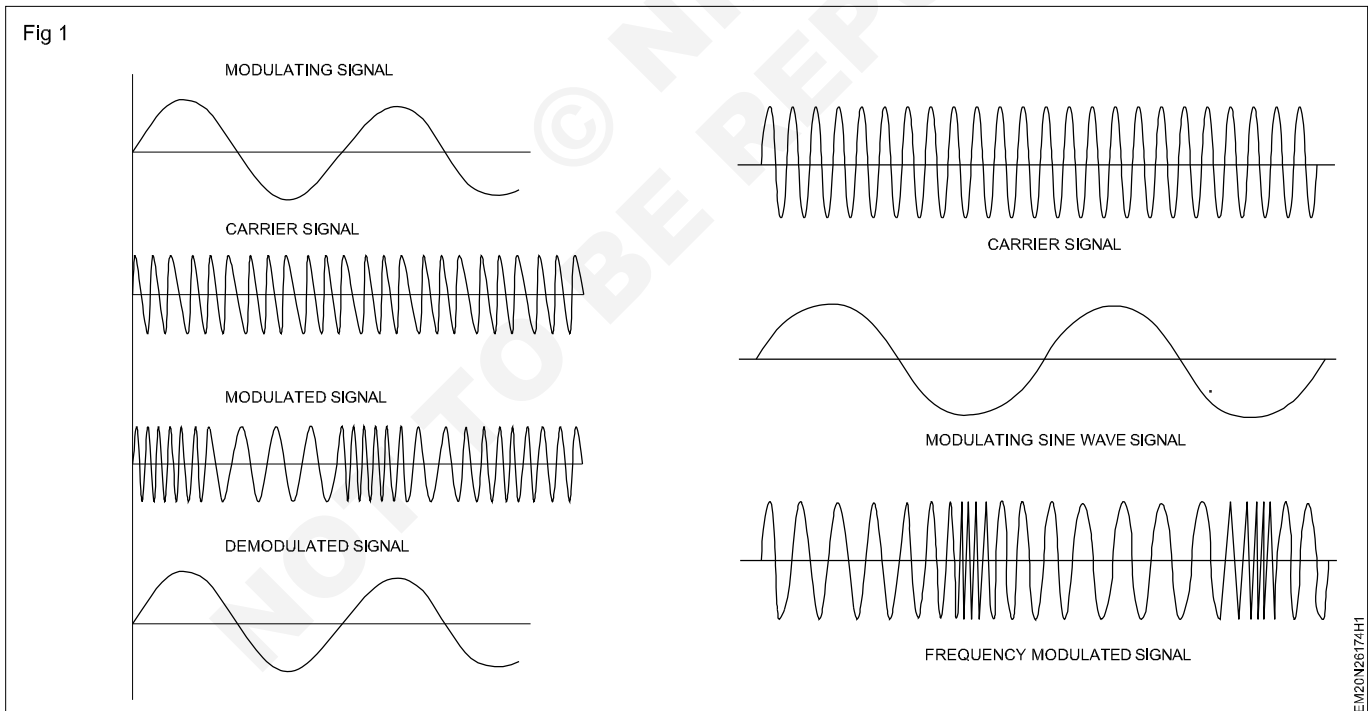

**Test IC based AM receiver**

**Objectives :** At the end of this exercise you shall be able to  
 • **construct and test IC MK 484 based AM receiver.**

Requirements	
<b>Tools/Equipments/Instruments</b>	
• Trainees tool kit	- 1 Set.
• Variable DC power supply (0-30V/2A)	- 1 No.
• Digital multimeter with probes	- 1 Set.
• FM radio receiver (working condition)	- 1 No.
<b>Materials / Components</b>	
• L1 make 55 turns of 30SWG enamelled copper wire on a 1 cm diameter card board former.	- 1 No.
Capacitors	
- 0.1 $\mu$ F/10 V	- 2 Nos.
- 0.01 $\mu$ F/10 V	- 1 No.
- 47 $\mu$ F/10 V	- 1 No.
• Head phone jack (female & male)	- 1 Set.
• Insulation tape PVC	- as reqd.
• Variable capacitor (ganged) 125 pF	- 1 No.
Resistors	
- 100 k $\Omega$ $\frac{1}{4}$ W	- 2 Nos.
- 1 k $\Omega$ $\frac{1}{4}$ W	- 2 Nos.
- 270 $\Omega$ $\frac{1}{4}$ W	- 1 No.
• IC MK 484 (with data sheet)	- 1 No.
• Transistor BC 548	- 1 No.
• Head phone 32 $\Omega$ (impedance)	- 1 No.
• Bread board/GP-PCB	- 1 No.
• Cell 1.5V	- 1 No.
• Ferrite rod-100mm length	- 1 No.
• 30 SWG Enamelled copper wire	- 5 m.
• card board piece (10 cm x 15 cm)	- 1 No.

**PROCEDURE**

**TASK 1 : Construction of IC MK 484 based AM receiver**

- 1 Collect all the materials/components required for the circuit as shown in Fig 1
- 7 Scrape the terminals of the coil, check continuity and solder at correct positions.

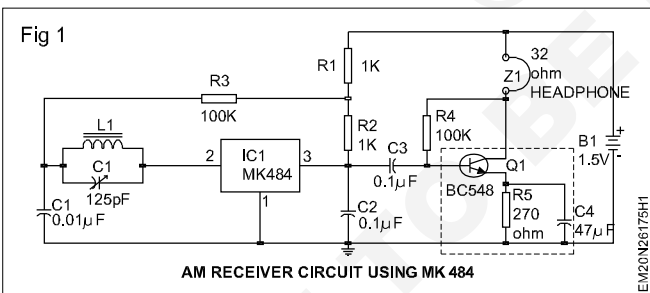

**Caution: Keep the coil with ferrite rod fixed on the board suitably**

- 2 Plan the layout of components on the Gen.purpose PCB suitably.
- 8 Fix the PVC gang capacitor, phono jack-female socket suitably and solder it on the PCB.
- 9 Verify the soldered connections with the circuit diagram.
- 10 Connect the headphone and switch ON the circuit.
- 11 Observe the sound signal, verify the gang capacitor tuned to the local AM radio station.
- 12 Get the work checked by the Instructor.

**Note: Refer to the data sheet of the ICMK 484, identify terminals.**

- 3 Insert all the components on the PCB as per the circuit and solder them.
- 4 Make a bobbin using the cardboard piece, roll around the ferrite rod tightly with insulation tape.
- 5 Wind 55 turns of the coil L1 using 30 SWG enamelled copper wire over the cardboard bobbin.
- 6 Cut two pieces of insulation tape and use them on the starting and end terminals on the coil L1.

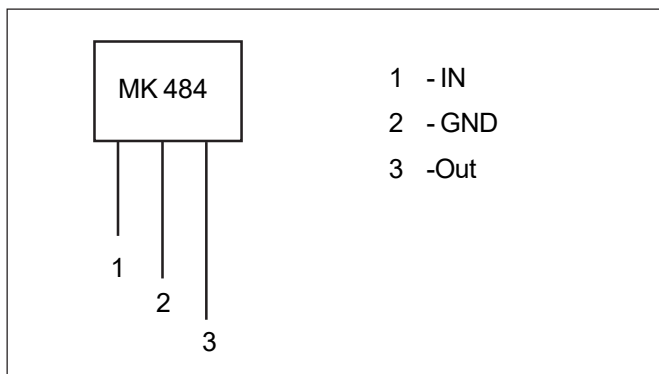

**Test IC based FM transmitter**

**Objective :** At the end of this exercise you shall be able to  
 • **construct & test an IC UPC 1651 based FM transmitter.**

**Requirements**

**Tools/Equipments/Instruments**

- Variable DC power supply 5 V - 1 No.
- Trainees tool kit - 1 Set.
- Digital multimeter with probes - 1 No.
- FM radio receiver (working condition) - 1 No.

**Materials / Components**

- L1 make 05 turns of 26 SWG enamelled copper wire on a 4 mm diameter card board former.
- Capacitors - 2 Nos.

- 100 pF - 1 No.
- 3.3  $\mu$  F/10 V - 1 No.
- Variable capacitor (ganged) 15 pF - 1 No.
- Resistor 4.7 k $\Omega$ , 1/4 W - 1 No.
- IC UPC 1651 - 1 No.
- 3/4 m insulated copper wire antenna - 1 No.
- DC power supply (0-30V/2A) - 1 No.
- Condenser microphone - 1 No.
- GP PCB/Bread board - 1 No.

**PROCEDURE**

**TASK 1 : Construction and testing an IC UPC 1651 based FM transmitter**

1 The circuit can be assembled on a GP-PCB board.  
 (Fig 1)

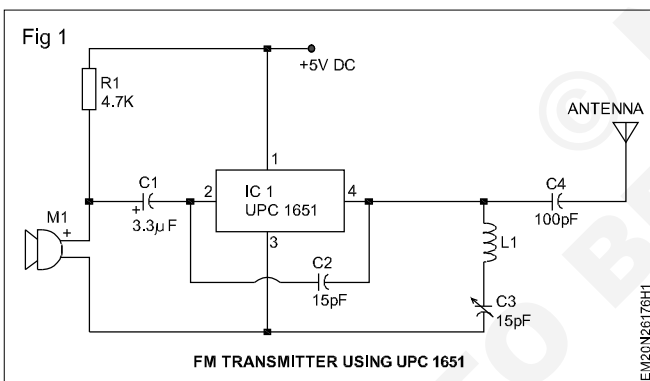

**Inductor L1 can be made by making 5 turns of 26 SWG enamelled copper wire on a 4 mm diameter plastic former.**

2 Connect 3/4 m insulated Cu wire as antenna

**Do not give more than 6V to the IC.  
 Mic M1 can be a condenser microphone.**

- 3 Connect the power supply to the circuit
- 4 Make some sound in the mic (song or speak or buzzer sound etc) connected to the FM Transmitter.
- 5 Use the FM radio receiver and tune it to test the transmitted sound/signal.

**Note: The Instructor has to guide the trainees to adjust the variable capacitor in the FM transmitter or the tuning of the FM receiver, one at a time, so as to receive good sound reception of the transmitted signal.**

- 6 Gradually increase the distance between the transmitter and receiver and observe the range of the transmitter.

**This setup can be used on a cordless mic.**

**Test IC based AM transmitter and test the transmitter power. Calculate the modulation index**

**Objectives :** At the end of this exercise you shall be able to

- **construct and test the IC based AM transmitter**
- **measure waveform and calculate percentage of modulation.**

Requirements	
<p><b>Tools/Equipments/Instruments</b></p> <ul style="list-style-type: none"> <li>• Trainees tool kit - 1 Set.</li> <li>• Variable DC power supply (0 - 30 V/2A) - 1 No.</li> <li>• RF power meter - 1 No.</li> <li>• DMM with probes - 1 No.</li> <li>• CRO (0 - 20 MHz; Dual trace with probe kit) - 1 Set.</li> </ul>	<p><b>Materials/Components</b></p> <ul style="list-style-type: none"> <li>• Bread board - 1 No.</li> <li>• IC 555 - 1 No.</li> <li>• Condenser mic - 1 No.</li> <li>• Resistor CR 25, 1kW, 390 W - 1 No each.</li> <li>• Ceramic Capacitor 0.001 <math>\mu</math>F - 1 No.</li> <li>• Electrolytic capacitor 1000<math>\mu</math>F/25V - 1 No.</li> <li>• Hook up wire - 4 m.</li> <li>• Linear graph sheet - 1 No.</li> </ul>

**PROCEDURE**

**TASK 1: Construction of IC based AM transmitter and test the power**

- 1 Collect all the components / materials required for the circuit as shown in Fig 1.

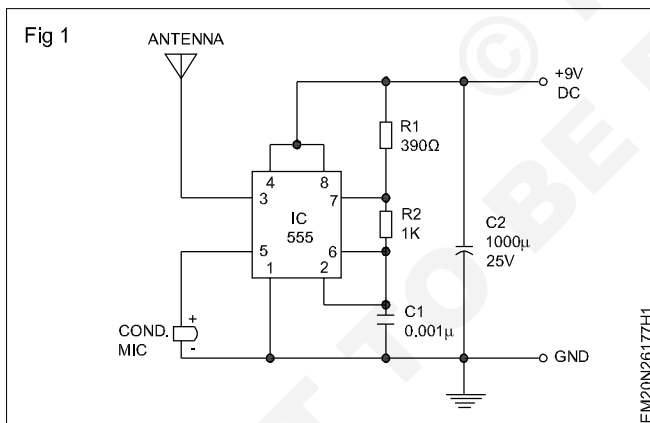

- 4 Connect 3 m long hookup wire at pin no. 3 as antenna.
- 5 Prepare the CRO for output measurement, connect across the AM transmitter circuit pin no. 3 and ground.
- 6 Switch ON 9VDC to the circuit and observe the waveform on the CRO
- 7 Speak through the condenser mic continuously and observe the maximum amplitude and minimum amplitude on the CRO.
- 8 Record the observations in Table 1.
- 9 Connect the RF power meter across pin no. 3 of IC 555 and ground. Repeat step 7 and 8 above.
- 10 Get the work checked by the Instructor.

- 2 Plan the layout of the components on the bread board, insert all the components and interconnect using hookup wire jumpers and assemble the AM transmitter.

**Note: Refer to the pin out of IC 555 and carefully insert onto the breadboard**

**Table - 1**

Minimum Amplitude	.....
Maximum Amplitude	.....
RF Power Meter Reading	.....

- 3 Verify the connection with correct polarity and pin number of IC 555.

-----

## TASK 2: Calculation of modulation index

- 1 Connect the CRO across the AM transmitter circuit at pin no.3 and ground
- 2 Switch ON the 9VDC and repeat step 7 of TASK - 1.
- 3 Draw the waveform on the graph sheet and mark the maximum and the minimum amplitude as shown in Fig 1

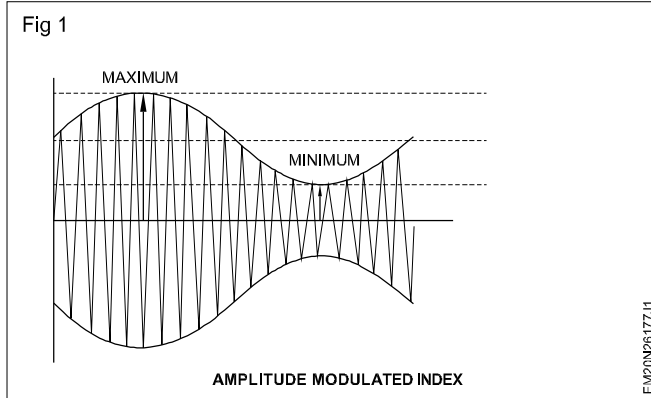

- 4 Use the following formula to calculate the modulation index

$$\text{Modulation Index}(m) = \frac{\left( \begin{array}{l} \text{Maximum amplitude} - \\ \text{Minimum amplitude} \end{array} \right)}{\left( \begin{array}{l} \text{Maximum amplitude} + \\ \text{Minimum amplitude} \end{array} \right)}$$

- 5 Substitute the maximum and minimum amplitude values observed and find the modulation index
- 6 Get the work checked by the instructor

**Dismantle the given FM receiver set and identify different stages (AM section, audio amplifier section etc)**

**Objectives :** At the end of this exercise you shall be able to

- **dismantle the given FM receiver using IC TEA5591A**
- **identify the stages of the FM receiver on the circuit board.**

<b>Requirements</b>		
<b>Tools/Equipments/Instruments</b>		
<ul style="list-style-type: none"> <li>• Trainees tool kit - 1 Set</li> <li>• DMM with probes - 1 No.</li> <li>• FM receiver using ICTEA5591 A - 1 No.</li> </ul>	<b>Aids:</b> Chart showing the print out diagram / data sheet of the IC TEA 5591 A and the PCB layout of AM/FM radio receiver	

<p><b>Note:</b></p> <ol style="list-style-type: none"> <li><b>1 The Instructor has to guide the trainees to open and dismantle the circuit board from the FM receiver without any damage to the windings/components</b></li> <li><b>2 Keep the screws, washer / nut &amp; bolt etc. separately</b></li> </ol>
---

**PROCEDURE**

- 1 Refer to the chart showing the FM receiver circuit diagram (Fig 1)
- 2 Identify the major components on the layout of circuit board
- 3 Identify the stages and location of different stages of FM receiver by tracing the PCB, from speaker side towards input side.
- 4 Record the observations in the Table - 1

**Table - 1**

S. No.	Name of the stage	Active devices in each stage	Remarks
1	Power supply (+ve)		
2	Ground terminal (-ve)		
3	FM RF input		
4	Mixer output		
5	FM oscillator		
6	IF amp (1 <sup>st</sup> ) input		
7	IF amp (1 <sup>st</sup> ) Output		
8	2nd IF amp. output		
9	FM Demodulator		
10	AF Output		

Fig 1

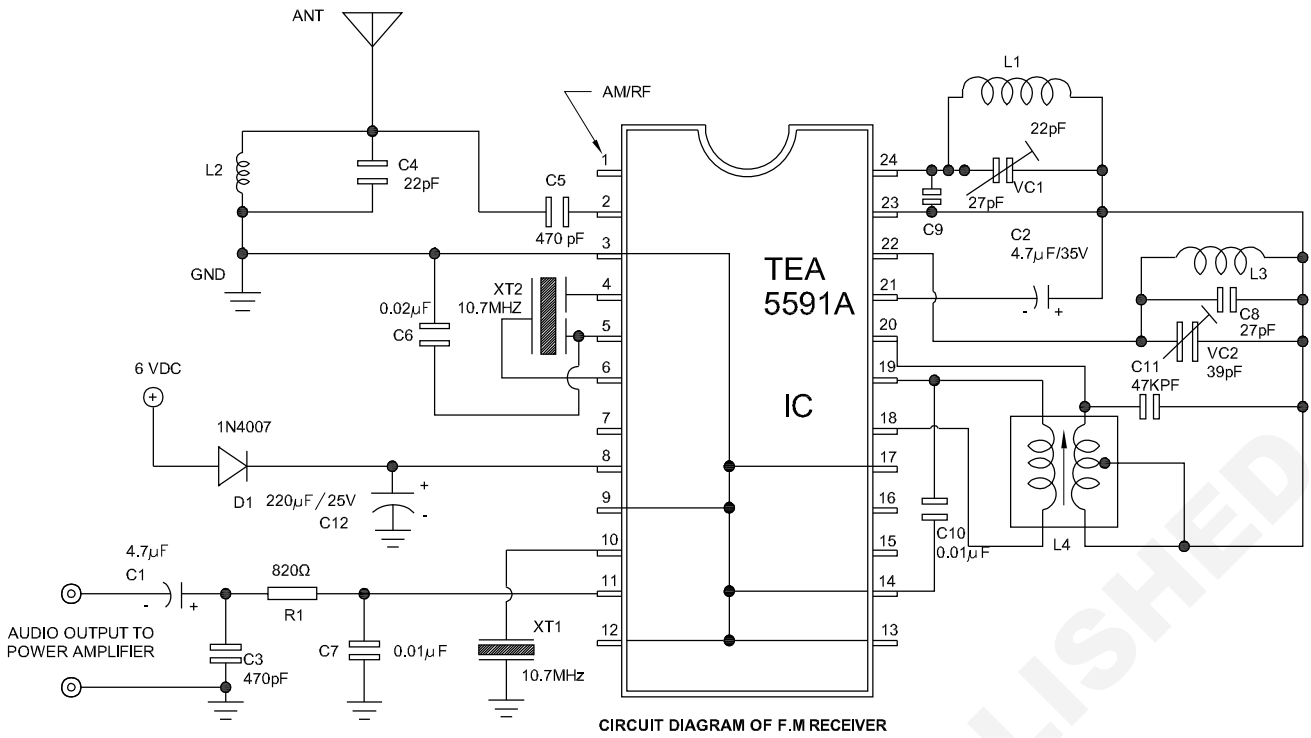

EM20N26178H1



**Modulate two signals using AM kit, draw the waveform and calculate the percentage (%) of modulation**

**Objectives :** At the end of this exercise you shall be able to

- modulate two signals using AM trainer kit/circuit
- measure waveform and calculate percentage of modulation.

Requirements	
<p><b>Tools/Equipments/Instruments</b></p> <ul style="list-style-type: none"> <li>• Trainees tool kit - 1 Set.</li> <li>• AM trainer kit with operating manual - 1 No.</li> <li>• DMM with probes - 1 Set.</li> <li>• CRO dual trace 0-20MHz with probe kit - 1 Set.</li> <li>• Audio generator - 1 No.</li> <li>• RF generator - 1 No.</li> <li>• Soldering iron -25W/240V - 1 No.</li> <li>• Regulated power supply 0-30VDC/2A - 1 No.</li> </ul>	<p><b>Materials/Components</b></p> <ul style="list-style-type: none"> <li>• Gen purpose PCB - 1 No.</li> <li>• Transistor BF 195C or equivalent - 1 No.</li> <li>• Resistor -CR25/ ¼ W</li> <li>• 10 kΩ - 3 Nos.</li> <li>• 20 kΩ - 1 No.</li> <li>• 100 kΩ - 1 No.</li> <li>• Capacitor ceramic 0.01µF, 0.1 µF, 0.001µF/25 VDC - 1 No each.</li> <li>• Resin cored solder - as reqd.</li> <li>• Flexible wire - as reqd.</li> </ul>

**PROCEDURE**

**TASK 1: Amplitude Modulation of two signals.**

**Note: The instructor has to use the AM trainer kit for this exercise. In case, the kit is not available, assemble the given Amplitude Modulator circuit using transistor for this task as shown in Fig 1.**

- 1 Refer to the operating manual of the AM trainer kit and follow the steps for modulating the built in audio signal as modulating signal (Fm).
- 2 Use RF carrier signal generator with 500 KHz frequency as carrier signal.
- 3 Prepare the CRO for measurement and connect the Ch-1 input with direct probes/crocodile clips.
- 4 Switch ON the AM trainer kit and connect the output of audio signal, carrier signal to the modulator section.
- 5 Connect the output of modulator section to CRO.
- 6 Adjust CRO and observe the stable waveform of modulated signal.

- 7 Measure the amplitude and record the observations in Table 1.
- 8 Get the work checked by the Instructor.

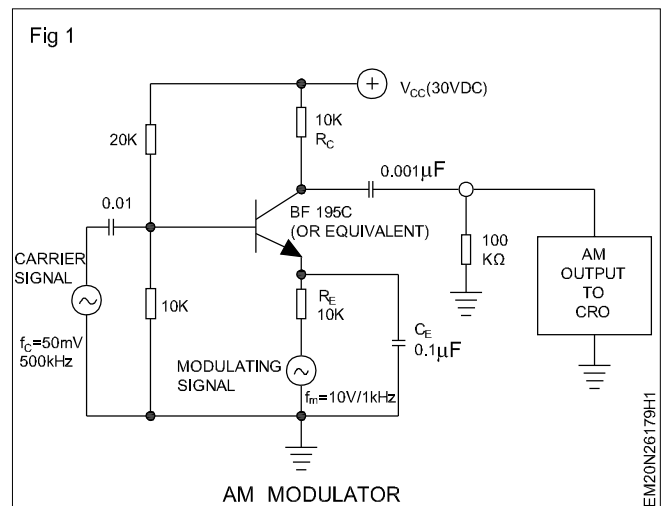
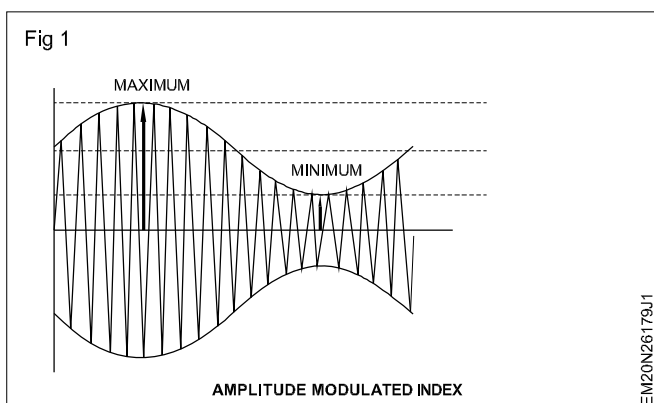

**Table 1**

SI.No	Signal	Waveform	Amplitude	Frequency	Remarks
1	Audio signal				
2	Carrier signal				
3	Modulator output				

## TASK 2: Calculate the modulation index

- 1 Refer to the amplitude modulated wave form draw the graph separately.
- 2 Note down the maximum amplitude and minimum amplitude as shown in Fig 1.



- 3 Use the following formula to calculate the modulation index.

$$\text{Modulation Index (m)} = \frac{\left( \begin{array}{l} \text{Maximum amplitude} - \\ \text{Minimum amplitude} \end{array} \right)}{\left( \begin{array}{l} \text{Maximum amplitude} + \\ \text{Minimum amplitude} \end{array} \right)} \times 100$$

- 4 Substitute the maximum amplitude and minimum amplitude values.
- 5 Find the modulation index.
- 6 Get the work checked by the Instructor.

**Modulate and demodulate signal using PAM, PPM, PWM techniques**

**Objectives :** At the end of this exercise you shall be able to

- **construct and test PAM modulator**
- **construct and test PAM demodulator**
- **construct and test PPM modulator**
- **construct and test PPM demodulator**
- **construct and test PWM modulator**
- **construct and test PWM demodulator.**

<b>Requirements</b>			
<b>Tools/Equipments/Instruments</b>			
• Variable DC power supply 0-30V/2A	- 1 No.	0.01 $\mu$ F /25 V	- 2 Nos.
• Digital multimeter with probes	- 1 No.	• <b>Resistors CR 25 <math>\frac{1}{4}</math> W</b>	
• CRO 20 MHz with instruction manual probe kit	- 1 No.	9.1 k $\Omega$	- 1 No.
• Audio frequency generator	- 1 No.	4.7 k $\Omega$	- 2 Nos.
• Trainees tool kit	- 1 Set.	10 k $\Omega$	- 1 No.
• Function generator	- 1 No.	330 $\Omega$	- 1 No.
		1 k $\Omega$	- 1 No.
		3.9 k $\Omega$	- 1 No.
		10 k $\Omega$	- 3 Nos.
<b>Materials/Components</b>		IC 555	- 3 Nos.
• <b>Capacitors:</b>		Diode 1N 4001	- 1 No.
10 $\mu$ F/35V	- 2 Nos.	Diode 1N 4007	- 1 No.
10 $\mu$ F/25V	- 1 No.	GP-PCB	- 2 Nos.
220 $\mu$ F/ 25V	- 1 No.	Transistor 2N2222A or equivalent	- 1 No.
10 $\mu$ F/25V	- 1 No.		

**PROCEDURE**

**TASK 1 : Construction and testing of PAM modulator**

- 1 Collect all the components, check them and assemble the astable multivibrator circuit as shown in Fig 1.
- 2 Prepare CRO for measurements with Ch-1 input.
- 3 Connect 5VDC power supply to astable multivibrator; Switch ON and measure the output at pin -3 of IC 555.
- 4 Switch ON the audio signal generator, adjust the output to 1 kHz and verify the waveform.
- 5 Connect the CRO probes across the collector and ground terminals of transistor Q1.
- 6 Measure the waveform and record the observations in Table-1.
- 7 Get the work checked by the Instructor.

**Table 1**

<b>Sl.No.</b>	<b>Measured wave form</b>	<b>Frequency</b>	<b>Remarks</b>
1	Pin no 3 of IC 555		
2	Audio generator output		
3	Collector of transistor Q1		

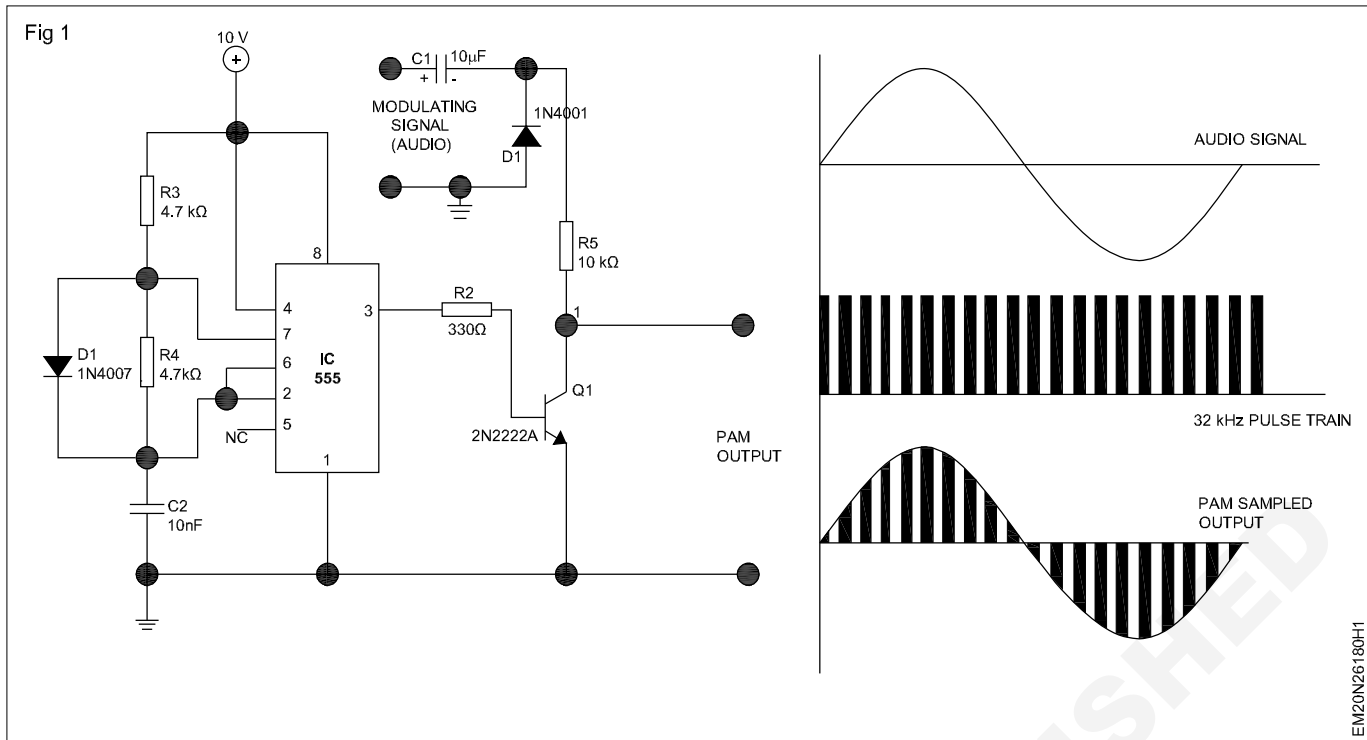

**TASK 2 : Construction and testing of PAM demodulator**

- 1 Assemble the RC circuit as shown in Fig 1 for the PAM demodulator stage.
- 2 Connect the output signal from the transistor Q1 of the circuit shown in Task 1 as input to the demodulator.
- 3 Switch ON the PAM modulator set up.
- 4 Measure the output signal across capacitor 'C' of PAM demodulator stage on the CRO.
- 5 Record the observation in Table 2.
- 6 Get the work checked by the instructor

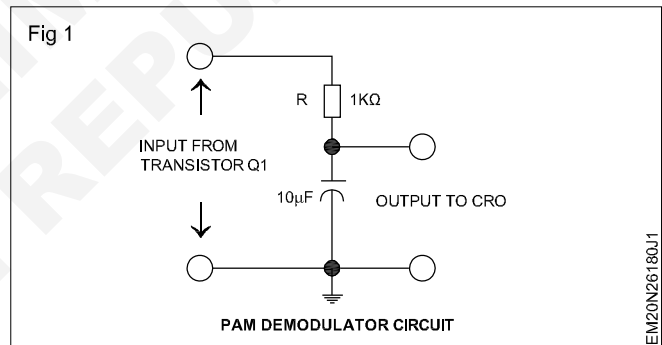

**Table 2**

Sl.No	Description	Waveform	Remarks
1	Input waveform at Pin No.3 of IC555		
2	Output waveform across capacitor 'C'		

### TASK 3 : Construction and testing PPM modulator

- 1 Collect all the components, check them and assemble the PPM modulator circuit as shown in Fig 1.
- 2 Connect the function generator output set at 1 KHz and 1 Vp-p, with triangular waveform to the pin no 5 of IC555.
- 3 Prepare CRO for measurement and connect Ch-1 with input signal (Pin-5).
- 4 Connect Ch-2 of CRO to the output Pin No 3 of IC555.
- 5 Switch ON the 5VDC supply to the PPM circuit.
- 6 Measure the waveform on the CRO and record the observations on Table-3.

Table 3

SI.No	Input / Output	Waveform	Remarks
1	Pin No. 5		
2	Pin No. 3		

- 7 Vary the triangular signal frequency and observe the effect on the output waveform.
- 8 Get the effect on the modulated output waveform checked by the Instructor.

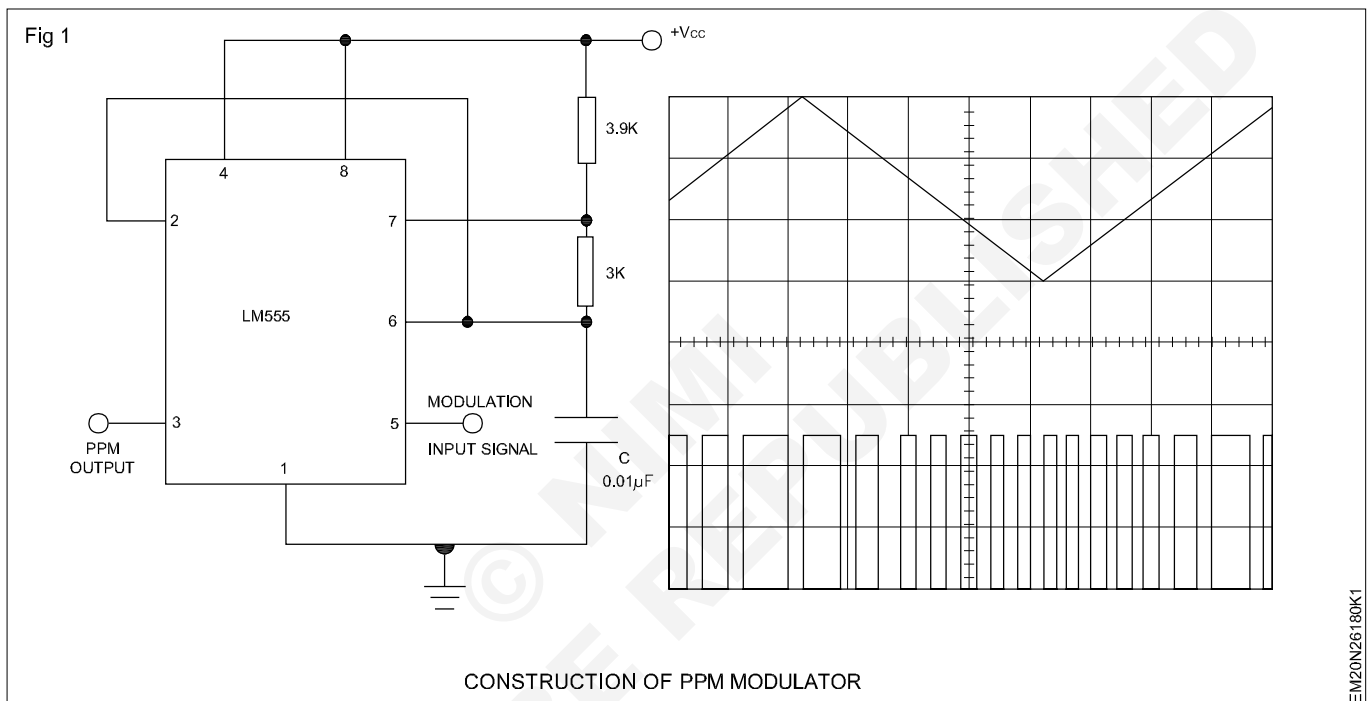

### TASK 4 : Construction and testing PPM demodulator

- 1 Use the assembled demodulator circuit of Task 2 (Fig 1) as the PPM demodulator.
- 2 Connect the output pin No 3 of PPM modulator circuit of Task 3 (Fig 1) as input signal to the above demodulator circuit.
- 3 Connect the function generator with sinewave set at 1 kHz -1 Vp-p output to the Pin No-5 of IC 555 as modulation signal input.
- 4 Switch ON the 5 VDC to the IC 555 and function generator, observe the waveform at Pin No 3.
- 5 Use CRO, measure the waveform across capacitor 'C' of PPM demodulator stage and record the observations on Table 4.
- 6 Get the effect on the demodulated waveform checked by the Instructor.

Table 4

SI.No	Description	Waveform	Remarks
1	Input Waveform across PPM demodulator		
2	Output Waveform across capacitor 'C' of PPM demodulator output		

### TASK 5 : Construction and testing PWM modulator

- 1 Modify the assembled board of Task 3 as per the circuit shown in Fig 1.
- 2 Connect sine wave signal from the function generator with 1 KHz, 1 Vp-p to the Pin No 5 of IC 555.
- 3 Switch ON the 5VDC supply and observe the output waveform at Pin No 3 of PWM modulator circuit.
- 4 Observe the effect on the output waveform by varying the sine wave signal.
- 5 Record the observations in Table-5.
- 6 Get the effect on the modulated output waveform checked by the Instructor.

Table 5

Sl.No	Description	Waveform	Remarks
1	Input Waveform at Pin No 5 of IC555		
2	Output Waveform at Pin No 3 of IC555		

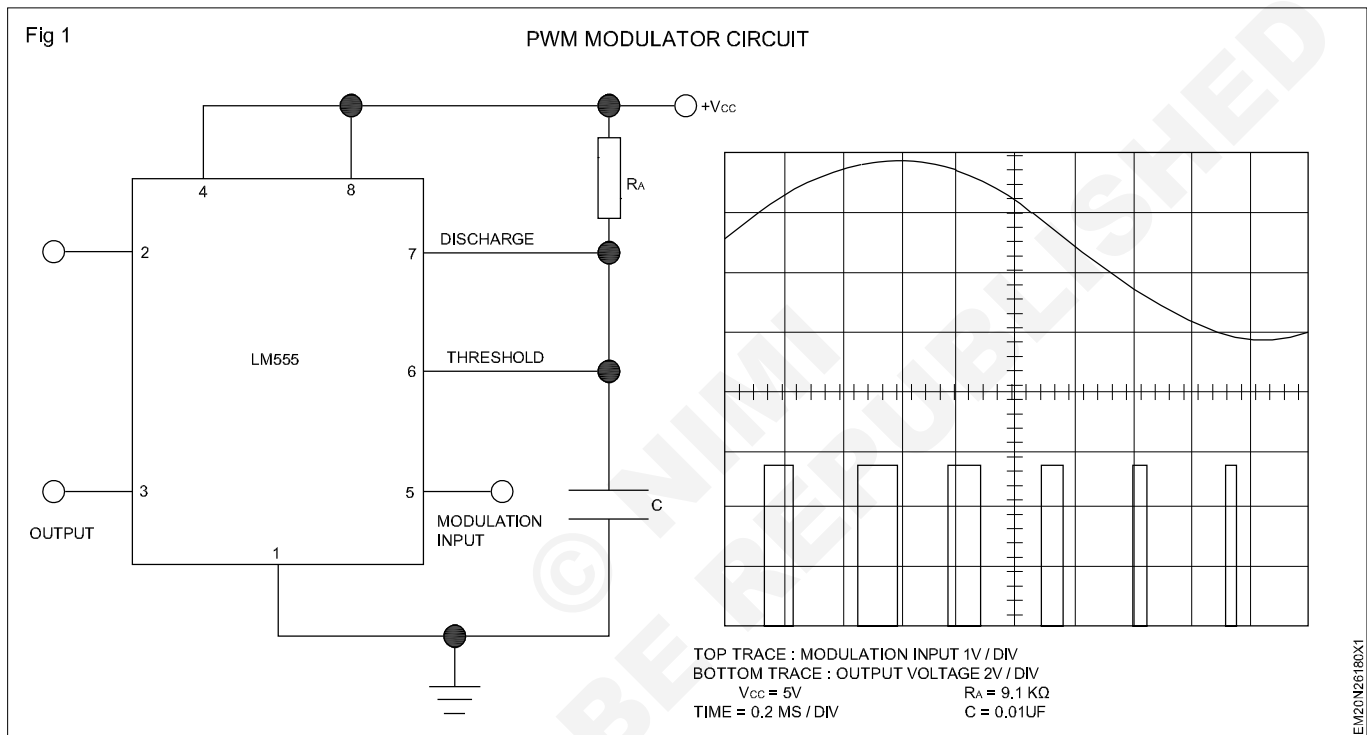

### TASK 6 : Construction and testing PWM demodulator

- 1 Use the assembled demodulator circuit of Task 2 (Fig 1 as the PWM demodulator).
- 2 Connect the output of PWM modulator Pin No 3 of IC555 of Task - 5 as the input signal to the PWM demodulator stage.
- 3 Connect the sinewave from the function generator with 1 KHz frequency, 1 Vp-p to Pin No 5 of IC 555.
- 4 Measure the output waveform across the PWM demodulator stage using CRO.
- 5 Record the observed waveforms across the input and output of PWM demodulator stage in Table 6.
- 6 Get the effect on the demodulated waveform checked by the Instructor.

Table 6

Sl.No	Description	Waveform	Remarks
1	Input Waveform across PWM demodulator		
2	Output Waveform across capacitor 'C'		

**Identify various ICs and their function on the given microcontroller kit**

**Objectives :** At the end of this exercise you shall be able to

- note down various ICs on the microcontroller trainer kit
- identify the function of ICs on the microcontroller trainer kit.

Requirements	
<b>Tools/Equipments/Instruments</b> <ul style="list-style-type: none"> <li>• 8051 Microcontroller Trainer kit with manual - 1 Set</li> <li>• Trainees tool kit - 1 Set.</li> <li>• Digital Multimeter with probes - 1 No.</li> </ul>	<b>Materials/Components</b> <ul style="list-style-type: none"> <li>• <b>Aids:</b> Layout diagram of ICs on the 8051 microcontroller kit - as reqd</li> </ul>

**PROCEDURE**

**Note:**

1. The Instructor has to prepare the layout diagram of ICs in the 8051 microcontroller trainer kit.
2. Label the main ICs for the functions like interfacing, RAM EPROM latch, buffer, keyboard controller, peripheral control etc. according to the microcontroller trainer kit available in the lab, to be provided along with the trainer kit for this exercise.

- 2 Open the top cover of the microcontroller trainer kit, and observe the ICs on the board with reference to the layout diagram.
- 3 Note down the code number/markings on each IC, number of pins and record the observations in Table - 1
- 4 Get the work checked by the Instructor

- 1 Collect the microcontroller trainer kit with its operating instructions manual (Fig 1).

**Table - 1**

S. No.	No of IC's	IC No.	No.of Pins	Function/ Pins of IC	Remarks Purpose
1	IC 1				
2	IC2				
3	IC3				
4	IC4				
5	IC5				

Fig 1

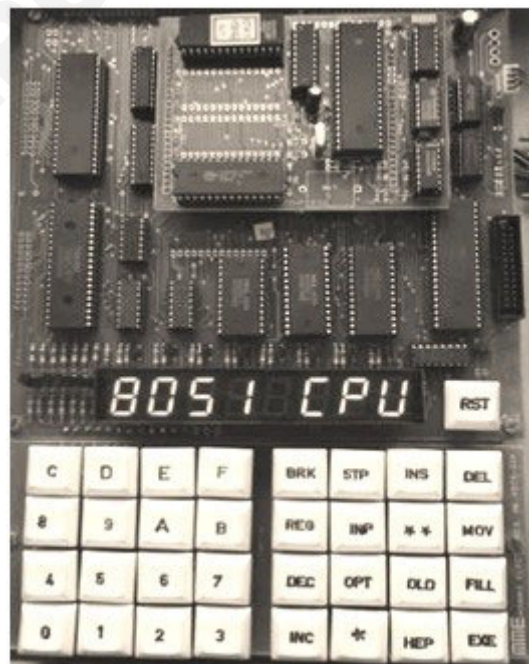

**Identify the address range of RAM & ROM of 8051 microcontroller**

**Objectives :** At the end of this exercise you shall be able to

- identify address range of RAM of the 8051 microcontroller trainer kit
- identify address range of ROM of the 8051 microcontroller trainer kit

Requirements	
<b>Tools/Equipments/Instruments</b> <ul style="list-style-type: none"><li>• 8051 microcontroller Trainer kit with manual</li></ul> - 1 Set	<b>Materials/Components</b> <ul style="list-style-type: none"><li>• Nil</li></ul>

**PROCEDURE**

**The Instructor has to refer the Instruction Manual of the 8051 microcontroller trainer kit and prepare the memory location of the RAM and ROM address range for the user programs in the trainer kit available in the lab**

- 5 Get the work checked by the instructor

Table - 1

Memory Type	Starting Address	End Address	Memory Capacity
RAM			
ROM			

- 1 Refer to the instruction manual of the microcontroller trainer kit, read the RAM address which is used to load user program
- 2 Refer to the instruction manual of the microcontroller trainer kit, read the ROM address which is used to load user program
- 3 Record the address of RAM and ROM used in the microcontroller trainer kit in the given tabular form
- 4 Calculate the memory capacity by subtracting the starting address from the end address (using hexadecimal number) and record in Table - 1.



**Measure the crystal frequency, connect it to the controller**

**Objectives :** At the end of this exercise you shall be able to

- identify the crystal oscillator in the given microcontroller kit
- measure the clock frequency of the given microcontroller kit.

<b>Requirements</b>			
<b>Tools/Equipments/Instruments</b>			
• 8051 Microcontroller Trainer kit with manual	- 1 Set	• Oscilloscope (0-20 MHz) with manual and probes	- 1 No.
• DMM with probes	- 1 No.	<b>Materials/Components</b>	
• Digital frequency meter	- 1 No.	• Nil	

**PROCEDURE**

**TASK 1 : Identification of crystal oscillator in the given microcontroller kit**

- |  |  |
|--|--|
| 1 Collect the microcontroller kit from the instructor.   | 7 Record the observed readings in the Table 1. |
| 2 Identify the crystal oscillator in the microcontroller kit.  | 8 Get the work checked by the Instructor.      |
| 3 Refer to the operating manual note down the freq and locate the pin number 18 and 19 of the microcontroller IC 8051 (refer Fig 1). |  |

**Note: Use DMM and measure the clock frequency by selecting the Hz range if available.**

- Prepare the CRO for measurements with Ch-1 input.
- Switch ON the microcontroller and measure the crystal signal waveform at pin 18 with respect to ground and calculate the frequency.
- Repeat step 5 at pin no. 19.



Fig 1

**TASK 2 : Measurement of clock frequency of the given microcontroller kit**

Table - 1

Clock frequency as per manual	CRO waveform/ frequency		Remarks
	Pin No. 18	Pin No. 19	

**Identify the port pins of the microcontroller and configure the ports for Input/Output operation**

**Objectives :** At the end of this exercise you shall be able to

- identify the port pins in 8051 microcontroller
- enter the program in the microcontroller kit and execute it.

Requirements	
<b>Tools/Equipments/Instruments</b> <ul style="list-style-type: none"> <li>• 8051 Microcontroller Trainer kit with manual - 1 Set</li> <li>• DMM with probes - 1 No.</li> <li>• Logic probes - 1 No.</li> </ul>	<b>Materials /Components</b> <ul style="list-style-type: none"> <li>• Program to operate the I/O port - as reqd.</li> </ul>

**PROCEDURE**

**TASK 1: Identification of port pins in 8051 microcontroller**

- 1 Collect the 8051 microcontroller kit and identify the sections using instruction manual
- 2 Identify the pin connection used for different ports on the microcontroller IC 8051
- 3 Notedown the pin number of ports in Table - 1, and mark the ports with dual function.
- 4 Note down the alternative pins of the ports in Table - 1
- 5 Get the work checked by the instructor

**Table - 1**

S. No.	Port Number	Pin Number	Alternative

**TASK 2: Entering the program into the microcontroller**

- 1 Refer to the instruction manual and identify all the operating controls and switches.
- 2 Connect the switch to port - 1
- 3 Configure the port - 1 as input port
- 4 Connect the output port to LEDs
- 5 Enter the given program and execute it on the trainer kit.

**Program**

```

LOOP   MOV A, P1
MOV    DPTR, #FF13
MOV    X @ DPTR, A
SJMP  LOOP
    
```

**Note:** The instructor has to explain about the given program and its working. The above program can be repeated for different Input/ Output ports.

**Note:** In the given program LED port address (FF13) is designed and tested as per the manufacturer of the microcontroller kit. It may vary for kits of different manufacturer / models.

6. Operate the switches one by one and verify the output by using LEDs

**Use 8051 microcontroller, connect 8 LEDs to the port and blink the LEDs with switch**

**Objectives :** At the end of this exercise you shall be able to

- enter the program to blink 8 LEDs using switch and run it on the microcontroller trainer kit
- check the result through the port - 1 and record the observation.

<b>Requirements</b>	
<p><b>Tools/Equipments/Instruments</b></p> <ul style="list-style-type: none"> <li>• 8051 Microcontroller trainer kit with instructional manual - 1 Set.</li> <li>• Trainees tool kit - 1 Set</li> <li>• Digital multimeter with probes - 1 No.</li> <li>• Logic probe - 1 No.</li> </ul>	<p><b>Materials/Components</b></p> <ul style="list-style-type: none"> <li>• 8 LEDs interface module (available on board) - 1 No.</li> <li>• Program to blink the 8 LEDs through switch - as reqd.</li> </ul>

**PROCEDURE**

**Note**

- 1 The instructor has to enter the program, execute and ensure that the 8051 microcontroller trainer kit is functioning correctly before given to the trainees for this exercise / task.
- 2 Make necessary modifications in steps / program according to the microcontroller trainer kit available in the section.

- 1 Collect the 8051 microcontroller trainer kit from the instructor
- 2 Refer to the instruction manual and identify all the operating controls / switches
- 3 Configure the port - 1 of 8051 microcontroller kit as input port

**The onboard 8 LED interface module connected internally is used for this task.**

- 4 Enter the given program to blink the 8 LEDs through switch into the microcontroller trainer kit
- 5 Execute the program and observe the blinking of LEDs
- 6 Get the work checked by the instructor

**Program**

```

LOOP   START   JNB 90, START
                MOV DPTR, #FF13
                MOV A, #FF
                MOV X, @DPTR, A
                LCALL DELAY
                MOV A, #00
                MOV X @DPTR, A
                LCALL DELAY
                SJMP LOOP
                DELAY LOOP
                MOV RO, #FF

LOOP 2   MOV R1, #FF
LOOP 1   DJNZ R1, LOOP 1
                DJNZ RO, LOOP 2
                RET
    
```

**Perform the initialization, load and turn ON a LED with delay using timer**

**Objectives :** At the end of this exercise you shall be able to

- enter the program to turn ON a LED with delay using timer in 8051 microcontroller trainer kit
- execute the program on the 8051 microcontroller trainer kit.

Requirements	
<b>Tools/Equipments/Instruments</b>	<b>Materials/Components</b>
<ul style="list-style-type: none"><li>• Trainees tool kit - 1 Set</li><li>• 8051 microcontroller trainer kit with instructional manual - 1 Set</li><li>• Logic probe - 1 No.</li></ul>	<ul style="list-style-type: none"><li>• Push-to-on switch - 1 No.</li><li>• Bread board - 1 No.</li><li>• Hook up wire - as reqd.</li><li>• Program to turn ON a LED with delay using timer - as reqd.</li></ul>

**PROCEDURE**

**Note**

- 1 The instructor has to make necessary modification in steps according to the microcontroller kit available in the lab.
- 2 Enter the program and test it before giving to the trainees.

- 1 Collect the 8051 microcontroller kit from the instructor
- 2 Refer to the instructional manual and identify all the operating controls / switches
- 3 Configure the port - 1 as output port
- 4 Enter the given program to turn ON the LED with delay using timer into the microcontroller kit
- 5 Execute the program and verify the result
- 6 Get the work checked by the instructor

**Main Program**

```
MOV TMOD, #10
HERE MOV TH1, #0F
MOV TL1, #F0
MOV A, #55
MOV 90, A
ACALL DELAY
ACALL DELAY
MOV A, #00
MOV P1, A
ACALL DELAY
ACALL DELAY
SJMP HERE
```

**Delay Program**

```
SET B TR1 (8E)
AGAIN JNB TF1 (8F), AGAIN
CLR TR1
CLR TF1
RET
```

**Perform the use of timer as an event counter to count external events**

**Objectives :** At the end of this exercise you shall be able to

- enter the program to count external events into the microcontroller kit
- observe the output using LED

**Requirements**

**Tools/Equipments/Instruments**

- Trainees tool kit - 1 Set.
- 8051 microcontroller trainer kit with instructional manual - 1 Set.
- Digital multimeter with probes - 1 No.
- Logic probe - 1 No.

**Materials/Components**

- Push-to-on switch - 1 No.
- Bread board - 1 No.
- Hook up wire - as reqd.
- Program to count external events - as reqd.

**PROCEDURE**

**Note:**

- 1 The instructor has to enter the program, execute that the 8051 microcontroller trainer kit is functioning correctly before given to the trainees for this exercise / task.
- 2 Connect the push button switch at pin No. 15 and ground using bread board and hook up wire.
- 3 Make necessary modifications in steps / program according to the microcontroller trainer kit available in the section.

- 1 Collect the 8051 microcontroller trainer kit from the instructor
- 2 Refer to the instructional manual and identify all the operating controls / switches

**The Instructor has to explain about the program and its working.**

- 3 Enter the given program into the microcontroller kit

**All the data and address are specified in Hexadecimal format only.**

**Program to count external events**

```
MOV TMOD, #60
MOV TH1, #00
SET B BO
AGAIN SET B TR1
LOOP MOV A, TL1
MOV DPTR, #FF13
MOV X @DPTR, A
JNB TF1, LOOP
CLR TR1
CLR TF1
SJMP AGAIN
```

- 4 Execute the program, press the push button and observe the output port LED
- 5 Repeat the above step for counting
- 6 Get the work checked by the instructor.

**Demonstrate entering of simple programs, execute and monitor the result**

- Objectives :** At the end of this exercise you shall be able to
- enter and execute the program to operate 8 bit addition
  - enter and execute the program to operate 8 bit subtraction.

Requirements	
<b>Tools/Equipments/Instruments</b>	<b>Materials/Components</b>
<ul style="list-style-type: none"><li>• Trainees tool kit - 1 Set</li><li>• 8051 microcontroller trainer kit with instruction manual - 1 Set</li><li>• Logic probe - 1 No.</li></ul>	<ul style="list-style-type: none"><li>• Program to operate two 8 bit addition - as reqd.</li></ul>

**PROCEDURE**

**TASK 1: Entering the program to operate two 8 bit addition**

**Note:**

- 1 The Instructor has to make necessary modifications in steps according to the microcontroller trainer kit available in the lab
- 2 Enter the program and test it before giving to the trainees

- 1 Collect the 8051 microcontroller kit from the instructor
- 2 Refer to the instruction manual and identify all the operating controls and switches
- 3 Enter the simple assembly language program to operate two 8 bit addition into the microcontroller
- 4 Execute the given program and verify the result
- 5 Record the datas and result in Table - 1
- 6 Repeat the steps 3 and 4 for different values and record it in Table - 1
- 7 Get the work checked by the Instructor

**Note: The Instructor has to explain about the program and its working**

**Program**

```
MOV RO, #00
MOV A, #data 1
ADD A, #data 2
JNC Label
INC RO
MOV DPTR, #address
MOV X @ DPTR, A
INC DPTR
MOV A, RO
MOV X @DPTR, A
HERE SUMP HERE
```

**TASK 2: Writing the program to operate two 8 bit subtraction**

**Note: The instructor should guide the trainees to write the program to operate two 8 bit subtraction, multiplication and division also**

- 1 Write the program to operate two 8 bit subtraction
- 2 Get the program checked by the instructor
- 3 Enter the program into the microcontroller kit and execute it
- 4 Verify the result and record it in Table - 1

**Table - 1**

S. No.	Mathematical	Data-1	Data-2	Result
1	Addition			
2	Subtraction			
3	Multiplication			
4	Division			

- 5 Get the work checked by the instructor

**Note: The Instructor my guide the trainees to write logical programs like AND, OR, NOT operations for practice.**

**Program**

```

CLR    C
MOV    A, #data 1
SUBB   A, #data 2
MOV    DPTR, #4500
MOV X  @ DPTR, A
HERE   SUMP  HERE
    
```

**Identification of different sensors used in process industries such as RTD, Temperature, ICs, Thermocouples, proximity switches (inductive capacitive photo electric) Load cells**

**Objectives :** At the end of this exercise you shall be able to

- identify the type of sensor used in process industries
- select suitable sensor for a specific purpose/application.

Requirements	
<p><b>Tools/Equipments/Instruments</b></p> <ul style="list-style-type: none"> <li>• Magnifier lamp - 1 No.</li> <li>• <b>Aids:</b> Chart showing the image of all the sensors with colour code, physical appearance and other details - 1 No.</li> </ul>	<p><b>Materials/Components</b></p> <ul style="list-style-type: none"> <li>• All types of sensors with instruction leaflet brochure - 1 No each. (RTD, Temperature IC i.e., Thermocouple, Proximity switch (inductive capacitive photo electric) Load cells, Strain gauge, LVDT, PT100 thermostat, float switch, float valve).</li> </ul>

**PROCEDURE**

**Note**

**1 The instructor has to label the RTD temperature IC, thermocouple, proximity switches (Inductive, capacitive and photoelectric), Load cell, strain gauge, LVDT float switch and float valve for water level.**

**2 Prepare technical data chart providing the type, code number and use/application for all the above sensors for this exercise.**

- 1 Pick one of the labeled sensor from the lot.
- 2 Observe the physical shape and constructional detail, refer to the chart -1 and identify the name of the sensor.
- 3 Use magnifier for viewing small/delicate details of the sensor.
- 4 Refer to the technical details of the selected sensor on the data chart, record the observations in Table -1.
- 5 Repeat the steps 1 to 4 for remaining sensing devices.
- 6 Get the work checked by the Instructor.

Table -1

Sl.No	Label No.	Name of the Sensor	Type/Colour Code/Number	Sensing Criteria	Using Application	Remarks
1						
2						
3						
4						
5						
6						
7						
8						
9						
10						



**Measure temperature of a lit fire using a Thermocouple and record the readings referring to data chart**

**Objectives :** At the end of this exercise you shall be able to

- identify and test the thermocouple using millivoltmeter (DMM) by quick test
- test the thermocouple with millivoltmeter and confirmation of correctness
- measure the output DC millivolt of Thermocouple at different temperatures and compare with standard values of data sheet.

Requirements			
Tools/Equipments/Instruments		Materials/Components	
• Trainees tool kit	- 1 Set	• Temperature sensors (assorted types)	- as reqd
• Digital Multimeter/millivolt meter with probes	- 1 Set	• Thermocouple J & K type sensor	- as reqd
• Steel rule 300mm and vernier	- 1 No	• Hot bath or water bath or heating source or Candle with match box	- 1 No
<b>Aids:</b>			
• Thermocouple Leads colour chart	- 1 No		
• Thermocouple temperature table	- 1 No		
• Thermocouple specification data sheet	- 1 No		

**PROCEDURE**

**Note: The instructor has to demonstrate the procedure to identify and test the thermocouple used for this exercise and label them serially.**

**TASK 1 : Identification of thermocouple from the assorted temperature sensors by quick test**

- 1 Take the digital multimeter and select low DC millivolts range.
- 2 Connect the DMM across the Thermocouple leads and observe the DC millivolts reading.
- 3 Heat the end of the thermowell bulb by using lit fire from candle or by using Hot bath or water bath or heating source.
- 4 Observe the DC millivolt reading on the meter and record the observations in Table-1.
- 5 Separate the temperature sensors into two groups which are changing DC millivolts and which are not changing DC millivolts for heating.
- 6 Mark the temperature sensor as "THERMOCOUPLE" that produced DC millivolts variation for change in temperature.

**Table 1**

Sl. No.	Label No.	Millivoltmeter reading		Remarks
		Before heating	After heating	
1				
2				
3				

- 7 Repeat steps 2 to 6 for the remaining sensors.
- 8 Get the work checked by the Instructor.

**Note: The sensors not responded for temperature change may be defective or RTDs.**



## TASK 2: Testing of thermocouple with millivoltmeter and confirmation of correctness

- 1 Collect the Thermocouple sensor from the Instructor.
- 2 Use the specification data sheet and note down type of sensor, material or element of sensor, and range of sensor calibrated, output of sensor in Table 2.
- 3 Note down physically observed data like thermowell length, thickness (dia), number of lead wires and their colours in Table 2 as shown in Fig 1.

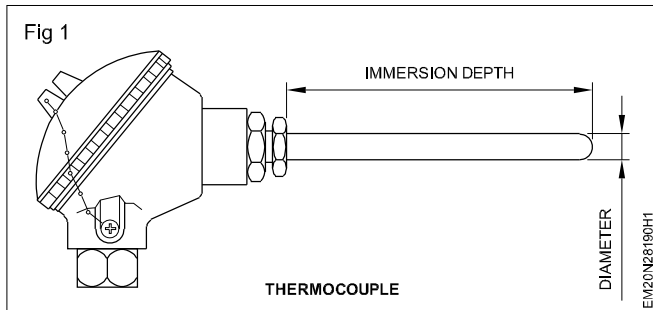

- 4 Select the millivolt range in DMM and connect the probes across the thermocouple leads.
- 5 Observe the DC millivolt reading at room temperature and record in Table 2.
- 6 Refer to the specification data sheet and verify the reading with above recorded observation for correctness of thermocouple.
- 7 Get the work checked by the Instructor.

Table 2

Specification of the thermocouple

Sl. No.	Description of Item	Details
1	Type of sensor	
2	Sensor element material	
3	Number of wires	
4	Lead colours	
5	Sensor output (if available)	
6	Sensor calibrated range (if available)	
7	Thermowell length (in mm)	
8	Thermowell dia (in mm)	
9	Thermowell material	
10	Thermowell thickness	
11	DC mV measured at room temperature	
12	DC mV recorded from thermocouple temperature data table at room temperature	

## TASK 3: Measuring the output DC millivolt of thermocouple at different temperatures

- 1 Collect the tested thermocouple from the instructor and fix it on the stand as shown in Fig 1.
- 2 Keep the steel rule by the side of stand and mark 5 divisions of 10 mm height from the bottom upto 50mm height.
- 3 Connect the millivoltmeter across thermocouple leads as shown in Fig 2, observe and record the reading as measurement at room temperature in Table 3.

**Note: Refer to the data sheet of the thermocouple and record the value in Table 2.**

- 4 Light the candle and keep the flame under the bulb of thermocouple at Level-1 (10 mm height).
- 5 Note down the millivoltmeter readings and record in Table-3.

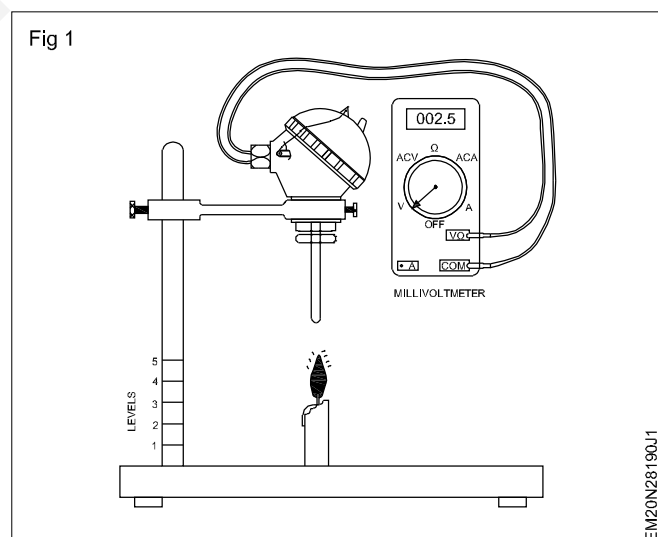

**Table 3**

<b>Sl. No.</b>	<b>Description</b>	<b>Millivoltmeter reading</b>	<b>Remarks</b>
1	Room temperature		
2	Level - 1 (10 mm)		
3	Level - 2 (20 mm)		
4	Level - 3 (30 mm)		
5	Level - 4 (40 mm)		
6	Level - 5 (50 mm)		

- 6 Increase the height of the candle to Level-2 (20mm height), note down the readings and record it.
- 7 Repeat the steps next Levels upto 50mm height and record readings in Table-3.
- 8 Get the readings checked by the Instructor and put out the candle fire.

-----

© NIMI  
NOT TO BE REPUBLISHED

**Measure temperature of a lit fire using RTD and record the readings referring to data**

**Objectives :** At the end of this exercise you shall be able to

- identify and check the RTD at room temperature
- measure the output DC millivolt of RTD at different temperature.

Requirements	
<p><b>Tools/Equipments/Instruments</b></p> <ul style="list-style-type: none"> <li>• Trainees tool kit - 1 Set</li> <li>• Digital Multimeter with probes - 1 No.</li> <li>• Steel rule 300 mm - 1 No.</li> <li>• RTD Leads colour chart - 1 Set</li> <li>• RTD temperature data sheet table - 1 No.</li> <li>• RTD specifications data sheet - 1 No.</li> <li>• <b>Aids:</b> Wall chart showing the types of temperature sensors. - 1 No.</li> </ul>	<p><b>Materials / Components</b></p> <ul style="list-style-type: none"> <li>• Temperature sensors assorted - as reqd.</li> <li>• RTD PT - 100 sensor - as reqd</li> <li>• Candle with match box - 1 No.</li> </ul>

**PROCEDURE**

**TASK 1: Identification of RTD from the assorted temperature sensors by quick test**

**Note: The instructor has to demonstrate the procedure to identify and test the RTD used for this exercise.**

- 1 Identify the RTD by physical appearance along with lead colours from the chart 1.
- 2 Use the DMM, select low resistance range and connect the ohm meter across the temperature sensor leads, observe the resistance value and record the readings in Table -1.
- 3 Lit the candle using match box.
- 4 Heat the end of the thermo well bulb by using the flame from candle.
- 5 Observe the variation of resistance value on Ohm meter and confirm the device under test is RTD.
- 6 Get the work checked by the Instructor.

**Note: The sensors not responded for temperature change may be defective or thermocouple.**

- 7 Use the RTD specification data sheet and note down the available name plate data like type of sensor, material of the sensor, resistance of sensor, calibrated, output of sensor and thermowell material in Table - 1.

- 8 Note down and record the physically observed, length, thickness, (dia), number of lead wires and their colours in Table - 1.

**Table 1**

Resistance value of RTD at room temperature = ....  
Ohms (as per data sheet)

Sl. No.	Description of Item	Details
1	Type of sensor	
2	Sensor element material	
3	Number of wires	
4	Lead colours	
5	Sensor output (if available)	
6	Sensor calibrated range (if available)	
7	Thermowell length (in mm)	
8	Thermowell dia (in mm)	
9	Thermowell material	
10	Resistance measured at room temperature	

- 9 Use the DMM select low resistance range, connect the ohm meter across the RTD leads, measure the resistance value at room temperature and record the reading in Table - 1.
- 10 Verify the resistance reading at room temperature from the RTD specification data sheet table and record in Table-1.

**Note: Compare the DMM reading with above observation for correctness of RTD.**

- 11 Get the work checked by the Instructor.

-----

**TASK 2 : Measuring the output DC millivolt of RTD at different temperature**

- 1 Collect the tested RTD from the Instructor and fix it on the stand as shown in Fig 1.

**Table 2**

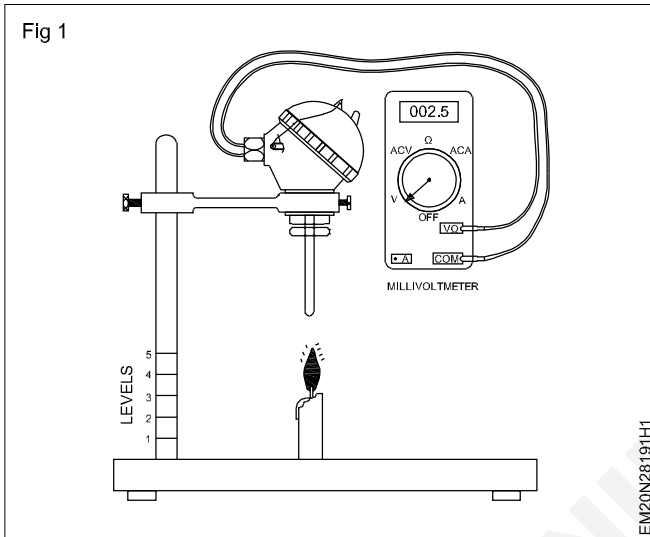

Sl. No.	Description	Millivoltmeter reading	Remarks
1	Room temperature		
2	Level - 1 (10 mm)		
3	Level - 2 (20 mm)		
4	Level - 3 (30 mm)		
5	Level - 4 (40 mm)		
6	Level - 5 (50 mm)		

- 2 Keep the steel rule by the side of stand and mark 5 divisions of 10 mm height from the bottom upto 50 mm height.
- 3 Connect the millivoltmeter across RTD Leads as shown in Fig 1, observe and record the reading as measurement at room temperature in Table - 2.

**Note: Refer to the data sheet of the RTD and record the value in Table - 2.**

- 4 Light the candle and keep the flame under the bulb of RTD at Level - 1 (10mm height).
- 5 Note down the millivoltmeter reading and record in Table - 2,
- 6 Increase the height of the candle to Level -2 (20mm height), note down the readings and record it.
- 7 Repeat the steps next levels upto 50mm height and record readings in Table - 2.
- 8 Get the readings checked by the Instructor and put out the candle fire.

-----

Measure the DC voltage of a LVDT

Objectives : At the end of this exercise you shall be able to

- test LVDT coils using multimeter
- measure the output voltages using CRO
- measure displacement using LVDT with indicator.

Requirements	
<b>Tools/Equipments/Instruments</b> <ul style="list-style-type: none"> <li>• Digital Multimeter with probes - 1 No.</li> <li>• Dual trace CRO (20 MHz) - 1 No.</li> <li>• Function generator - 1 No.</li> <li>• BNC cord for CRO - 1 No.</li> <li>• LVDT trainer kit with manual - 1 No.</li> </ul>	<b>Materials / Components</b> <ul style="list-style-type: none"> <li>• Connecting wires - 1 Set</li> </ul>

PROCEDURE

TASK 1: Testing of LVDT coils using multimeter (Ohm meter)

- 1 Collect the required tools and equipments
- 2 Take the LVDT and identify the primary and secondary coils by using its markings and positions. as shown in Fig 1.
- 3 Take multimeter and select low resistance range.
- 4 Measure the resistance across primary and secondary coils using ohms range. Note the readings in Table 1.
- 5 Get the work checked by instructor.

Table 1 : Strain gauge resistances

Coil	Resistance in ohms
Primary coil	
Secondary coil 1	
Secondary coil 2	

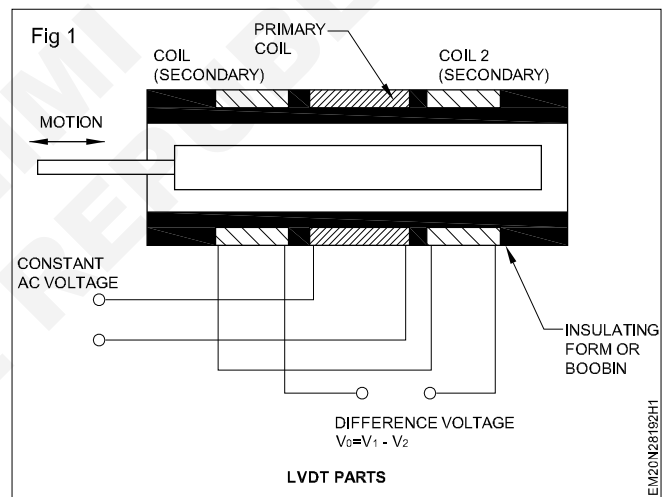

TASK 2: Measurement of output voltages using CRO

- Connect the primary coil of LVDT to the trainer kit / function generator refer Fig 1 for all connection.

**Note: primary coil can also be tested using function generator by selecting 1 KHz sign wave frequency.**

- Connect the Channel 1 of CRO across to the primary coil of LVDT.
- Connect the secondary of LVDT to the channel 2 of CRO.

- Switch on the trainer power supply.
- Place the core in centre of LVDT and observe the wave forms. Plot wave form in observations.
- Move the core forward direction and observe the wave form phase and magnitude. Draw the wave forms at maximum displacement.
- Bring back the core in centre and move the core in reverse direction. Observe the wave form phase changing and magnitude variation. Draw the wave form at maximum displacement as shown in Fig 2

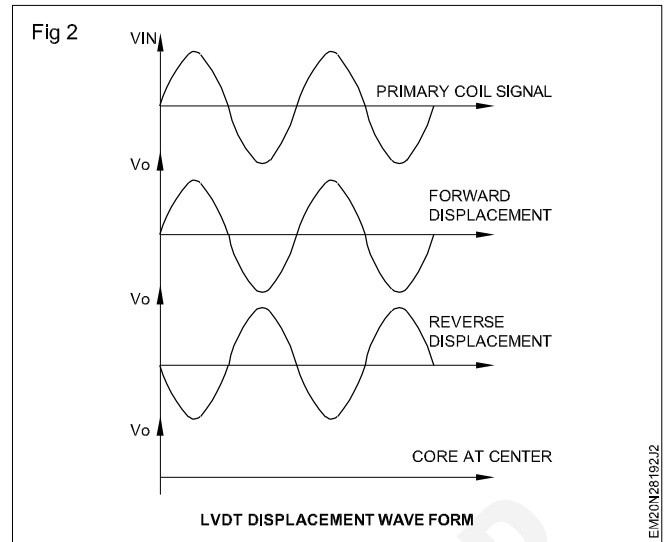
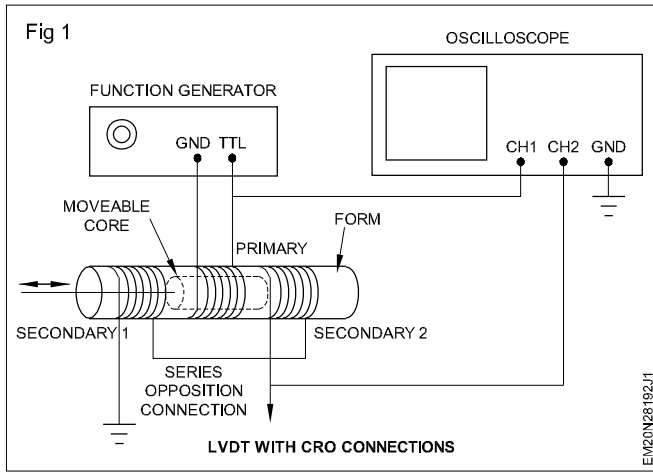

**TASK 3: Displacement measurement using LVDT with indicator**

- 1 Connect the LVDT coils to LVDT signal conditioner (indicator) or trainer kit.
- 2 Place the Core in middle of the LVDT or zero position in indicated scale.
- 3 Adjust the zero knob and make display zero.
- 4 Move the LVDT in forward movement at maximum i.e. 20 mm.
- 5 Adjust the span knob and make display 20 mm read out.
- 6 Repeat steps 1 to 5 up to system gets stable readings.
- 7 Move the LVDT core in steps of 5 mm upto 20 mm in forward and reverse movement.
- 8 Note down the reading in Table 2, for each 5 mm change.
- 9 Compare the readings and confirm.
- 10 Get the work checked by the instructor.

**Table 2 : Displacement vs Voltage**

S.No	Core displacement in (mm)	Output voltage with polarity
1		
2		
3		
4		
5		
6		

**Detect different objectives using capacitive, inductive and photoelectric proximity sensors**

**Objectives :** At the end of this exercise you shall be able to

- construct inductive proximity sensor circuit and test it
- construct capacitive proximity sensor circuit and test it
- construct photo electric proximity sensor circuit and test it.

Requirements			
<b>Tools/Equipments/Instruments</b>			
• Trainees tool kit	- 1 Set	• Resistor CR 25-2k2, 3k9, 4k7	- 1 No.each
• Soldering iron 25 watts/240 V	- 1 No.	• Resistor 150 Ohm/ W/CR25	- 2 Nos.
• Regulated power supply 0-30V/2A	- 1 No.	• PC 817 Optocoupler	- 1 No.
• DMM with probes	- 1 No.	• Bread board	- 1 No.
		• Proximity sensor PNP type	- 1 No.
		• Photo electric sensor	- 1 No.
		• Microswitch	- 2 Nos.
		• LM 7805	- 1 No.
		• PSA - 6B inductive sensor	- 1 No.
		• Hook up wire	- 2m
		• Rosin cored solder	- as reqd.
<b>Materials / Components</b>			
• IC CD 4026	- 2 Nos.		
• 7 Segment display common cathode	- 2 Nos.		

**PROCEDURE**

**TASK 1: Construction and testing the inductive type proximity sensors**

**Note: The instructor has to guide the trainees to fix the proximity sensor (inductive/photo electric sensors) and adjust the distance detection sensitivity to detect the objects**

- 1 Collect all the components, plan the layout of the display device, counter IC and all other components on the bread board / PCB
- 2 Check all the components and assemble the counter circuit as per the schematic diagram shown in Fig 1 except the proximity sensor
- 3 Switch on the 12V DC power supply, press the reset switch 1 and observe the seven segment display shows zero
- 4 Pick and identify the terminals of the inductive proximity sensor, connect it on the circuit as input.
- 5 Bring a piece of iron object and move it in front of the sensor such that it detect the object and the display changed to show the number '1'.

- 6 Repeat the object number of times and observe the display shows incremental numbers confirming the detection of the object.
- 7 Record the number observed in Table - 1

**Table - 1**

S. No.	No. of attempts	Number displayed	Remarks
1	First		
2	Second		
3	Third		
	.....		
	.....		

- 8 Get the work checked by the Instructor and switch off the circuit



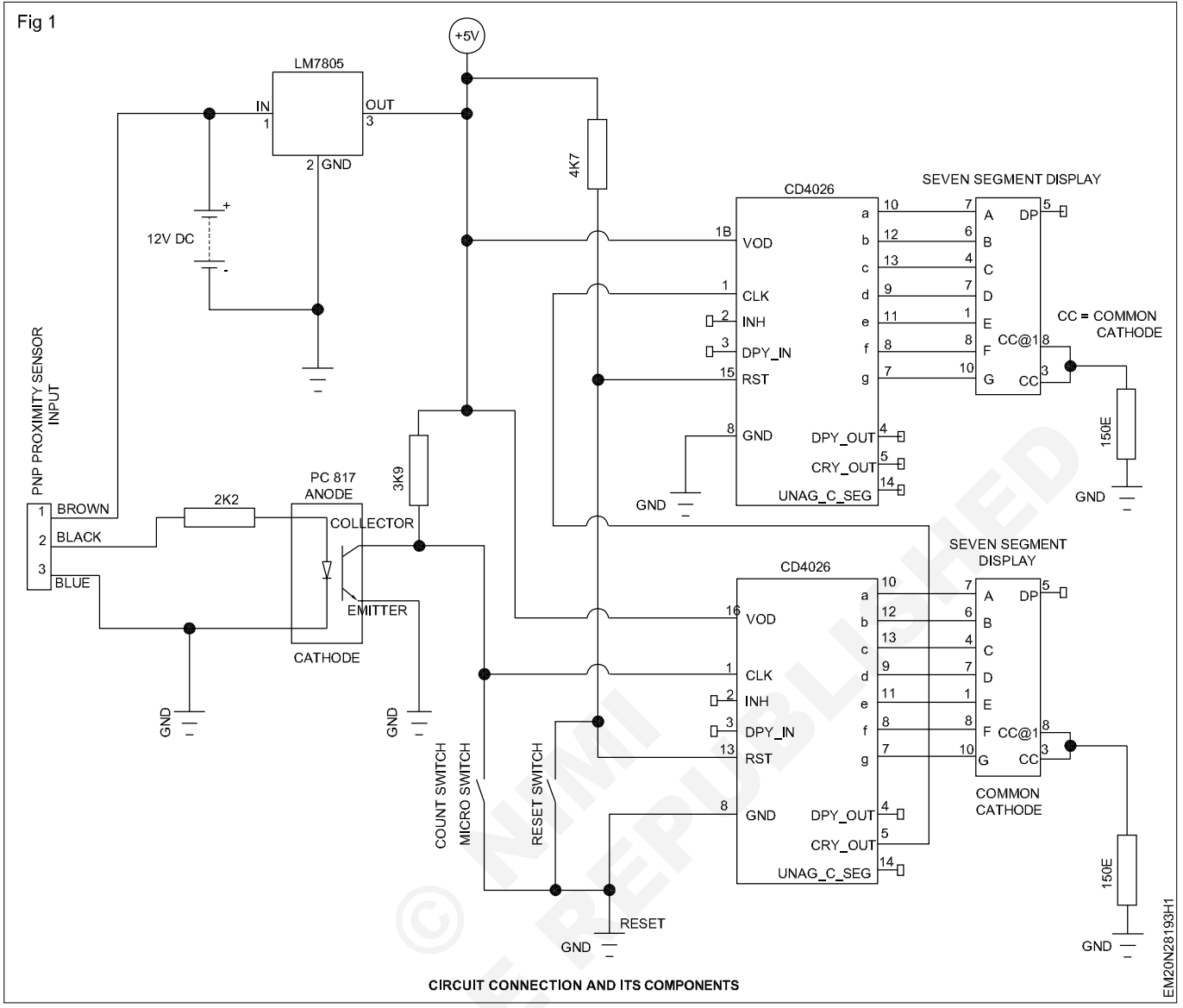

**TASK 2: Construction and testing of capacitive proximity sensor**

- 1 Use the counter circuit assembled as per the step 1 to 3 of Task - 1
- 2 Pick the three wire capacitive proximity sensor and identify the terminals, connect it to the input of counter circuit
- 3 Switch ON the 12V DC power supply and observe the display
- 4 Pick any object and bring it very closer to the proximity sensor input and observe the display for any change
- 5 Repeat the above step number of times and observe the increment of number in the display to confirm the detection of the object
- 6 Record the number observed in Table 3.
- 7 Get the work checked by the instructor and switch off the circuit

**Table 2**

S. No.	No. of attempts	Number displayed	Remarks
1	First		
2	Second		
3	Third		
	.....		
	.....		

**Note: The circuit will display upto the number 99. Exceeding this limit another set of IC CD 4026 and seven segment display may be added.**

**TASK 3: Construction and testing of photo electric type of proximity sensor**

- 1 Use the assembled counter circuit as per the step 1 to 3 of Task -1
- 2 Pick the photoelectric proximity sensor, identify the terminals and connect it to the counter circuit input.
- 3 Switch ON the 12 V DC power supply and observe the display.
- 4 Pick any item/object, bring it closer to the proximity sensor and observe for any changes in the display
- 5 Repeat the above step with any ferrous or non-ferrous objects and observe the change in display to confirm the detection of the object.
- 6 Record the number observed in Table - 2
- 7 Get the work checked by the instructor and switch OFF the circuit

**Table - 3**

S. No.	No. of attempts	Number displayed	Remarks
1	First		
2	Second		
3	Third		
	.....		

© NIMI  
NOT TO BE REPUBLISHED

## Connect and test microcontroller based arduino board to computer and execute sample programs

**Objectives:** At the end of this exercise you shall be able to

- to connect microcontroller based arduino board to computer and execute sample programs
- to execute simple programs.

### Requirements

#### Tools/Instruments

- Arduino uno board
- PC with Arduino IDE installed.

### PROCEDURE

#### TASK 1 : Connect microcontroller based arduino board to computer and execute simple programs

- 1 Take an microcontroller arduino board. Connect it with the PC using USB cable as given in Fig 1 and also before that install the arduino app software in PC or laptop

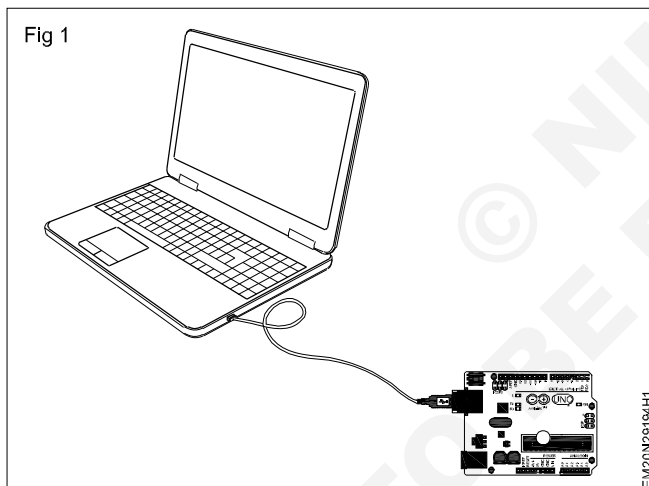

- 2 Open the arduino application icon as given in Fig 2
- 3 Select the arduino board. Go to Tools ? Board and select your board as shown in Fig 3
- 4 Select the serial port. Go to Tools ? Serial Port menu as show in Fig 4
- 5 To open existing project example select File ? Example ? Basics ? Blink as shown in Fig 5
- 6 Code will be displayed in the screen as in Fig 6 and code as shown in below.
- 7 Click the upload button as shown in Fig 7
- 8 Observe the Arduino board where light will be blinking(yellow color) as shown in Fig 8

Fig 2

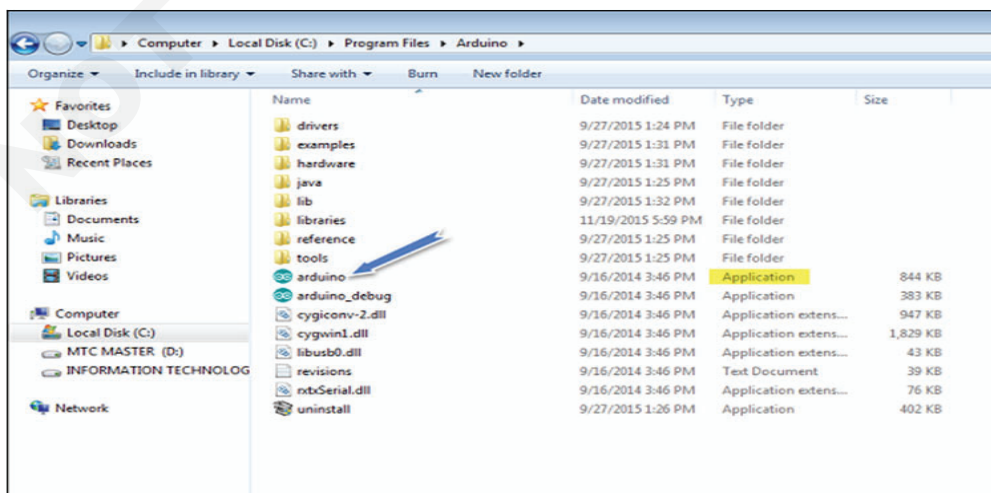

Fig 3

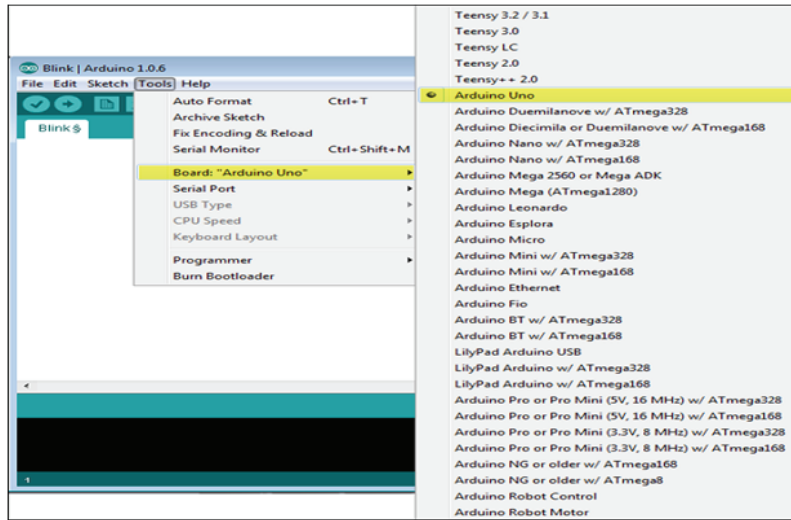

Fig 4

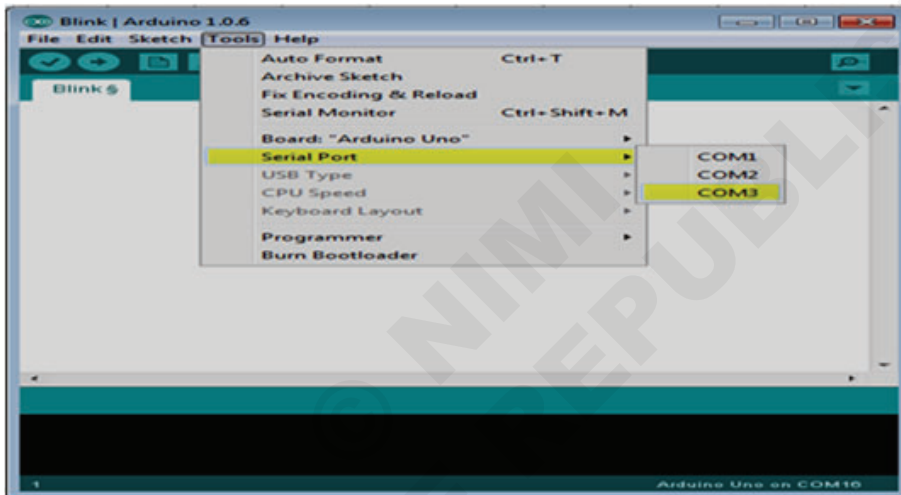

Fig 5

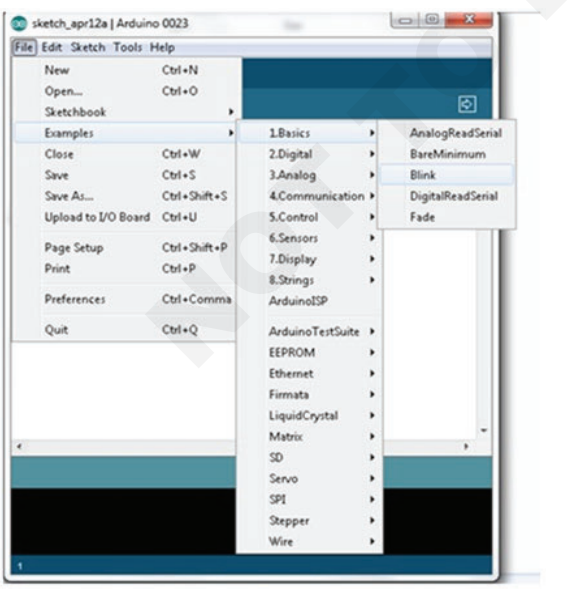

Fig 6

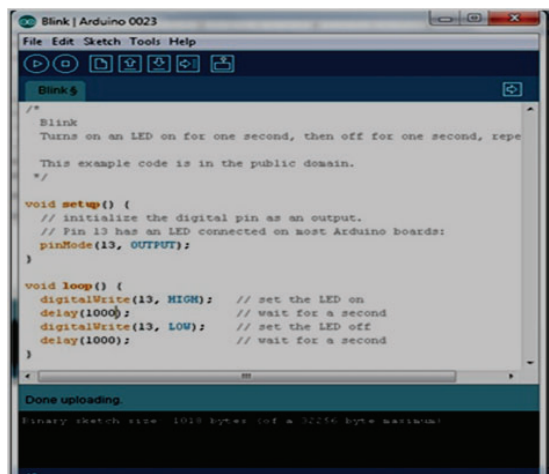

Fig 7

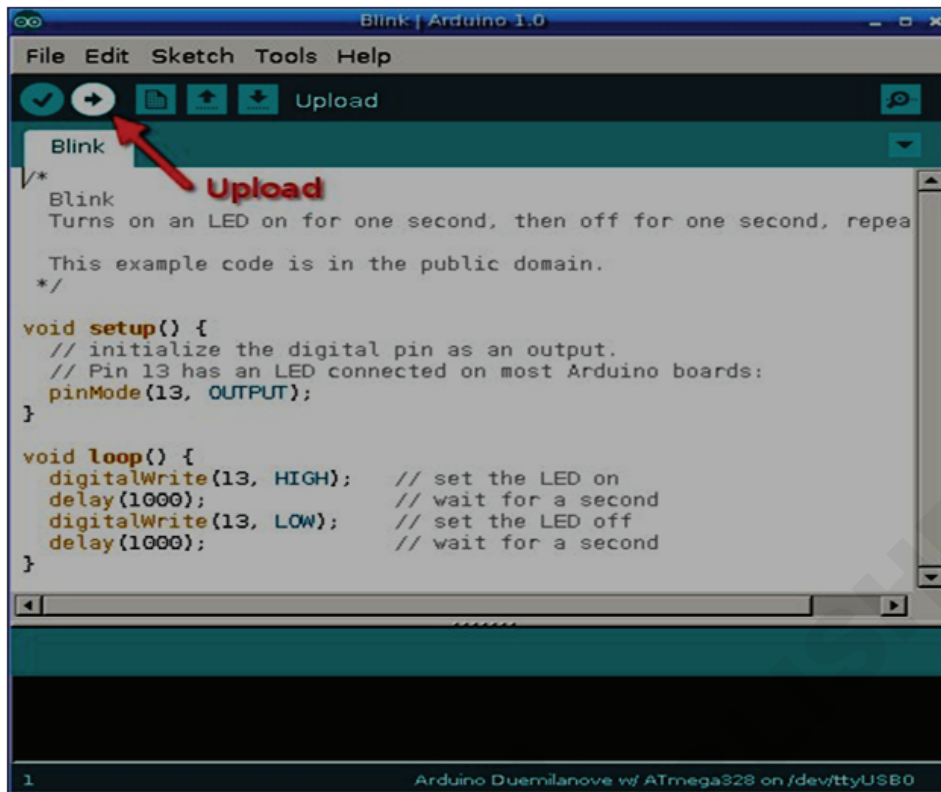

Fig 8



**Note : Students can try other example sketches in the Arduino IDE**

- Observe the output.

## Upload computer code to the physical board (microcontroller) to blink a simple LED

**Objectives:** At the end of this exercise you shall be able to

- to execute simple programs.

### Requirements

#### Tools/Instruments/Equipments

- Microcontroller Arduino uno board
- LED bulb
- Resistor
- PC with Arduino IDE installed
- Jumper Wires
- Breadboard

### PROCEDURE

#### TASK 1 : To execute simple programs

- 1 Follow the steps in Exercise 2.9.194 till steps 4.
- 2 Create a new project File ? click “New” option as shown in Fig 1, Enter the code as shown in below.

Fig 1

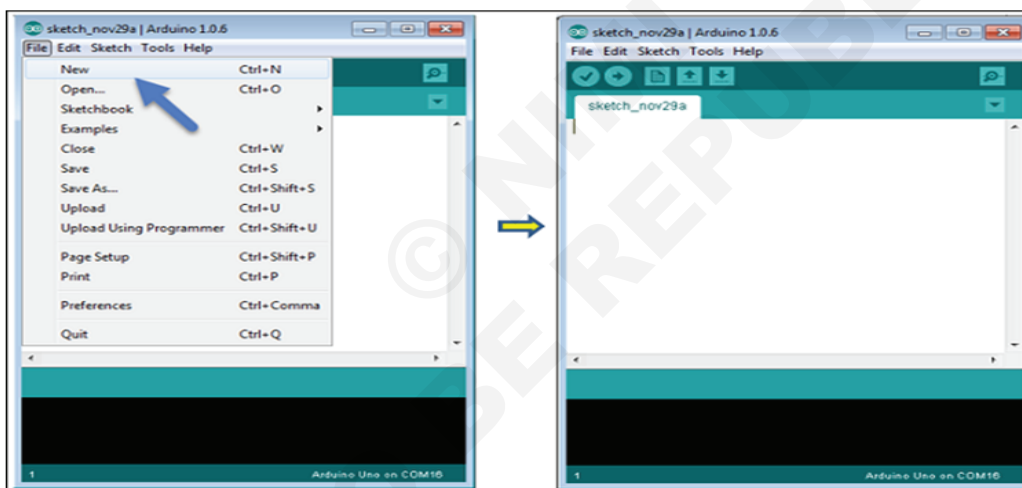

- 3 Enter the code

```
/*  
Blink  
Turns on an LED on for one second, then off for one  
second, repeatedly.  
This example code is in the public domain.  
*/  
// Pin 13 has an LED connected on most Arduino  
boards.  
// give it a name:  
int led = 13;  
// the setup routine runs once when you press reset:  
void setup(){  
// initialize the digital pin as an output.
```

```
pinMode(led, OUTPUT);  
}  
// the loop routine runs over and over again forever:  
void loop(){  
digitalWrite(led, HIGH);  
// turn the LED on (HIGH is the voltage level)  
delay(1000);  
// wait for a second  
digitalWrite(led, LOW);  
// turn the LED off by making the voltage LOW  
delay(1000);  
// wait for a second  
}
```

- 4 Get ready with the below components (Fig 2)
- 5 Connect the LED with Arduino using breadboard as shown in Fig 3
- 6 Repeat as in Exercise 2.9.194
- 7 Observe the LED glowing which is fixed in breadboard. Do the Exercise.

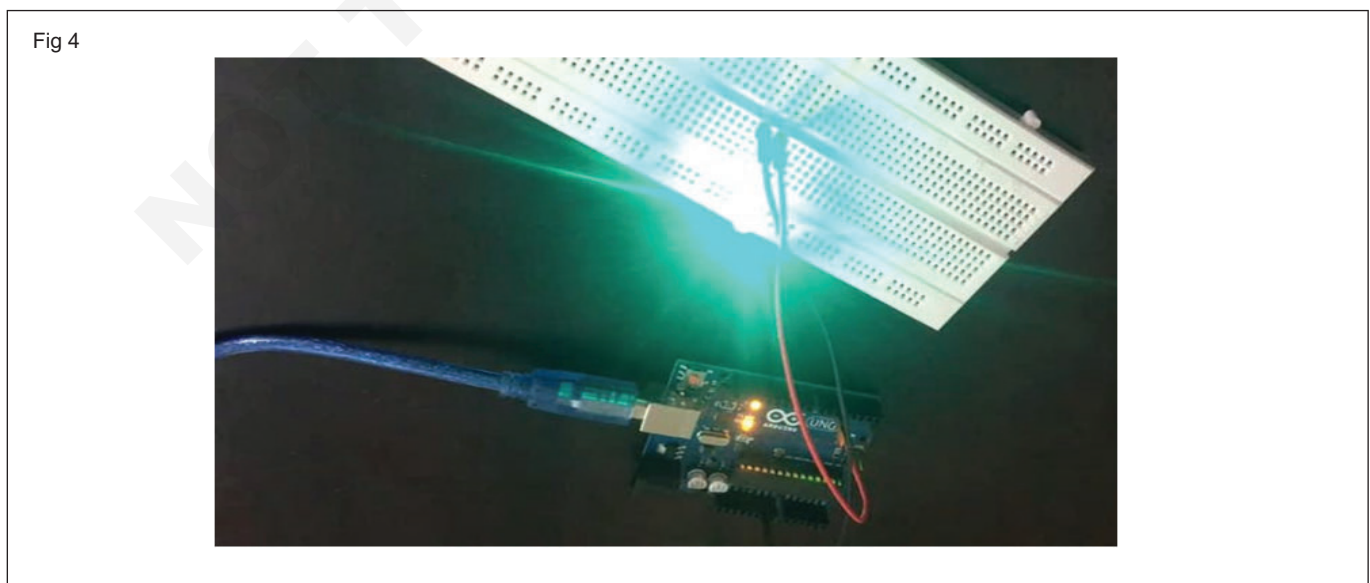
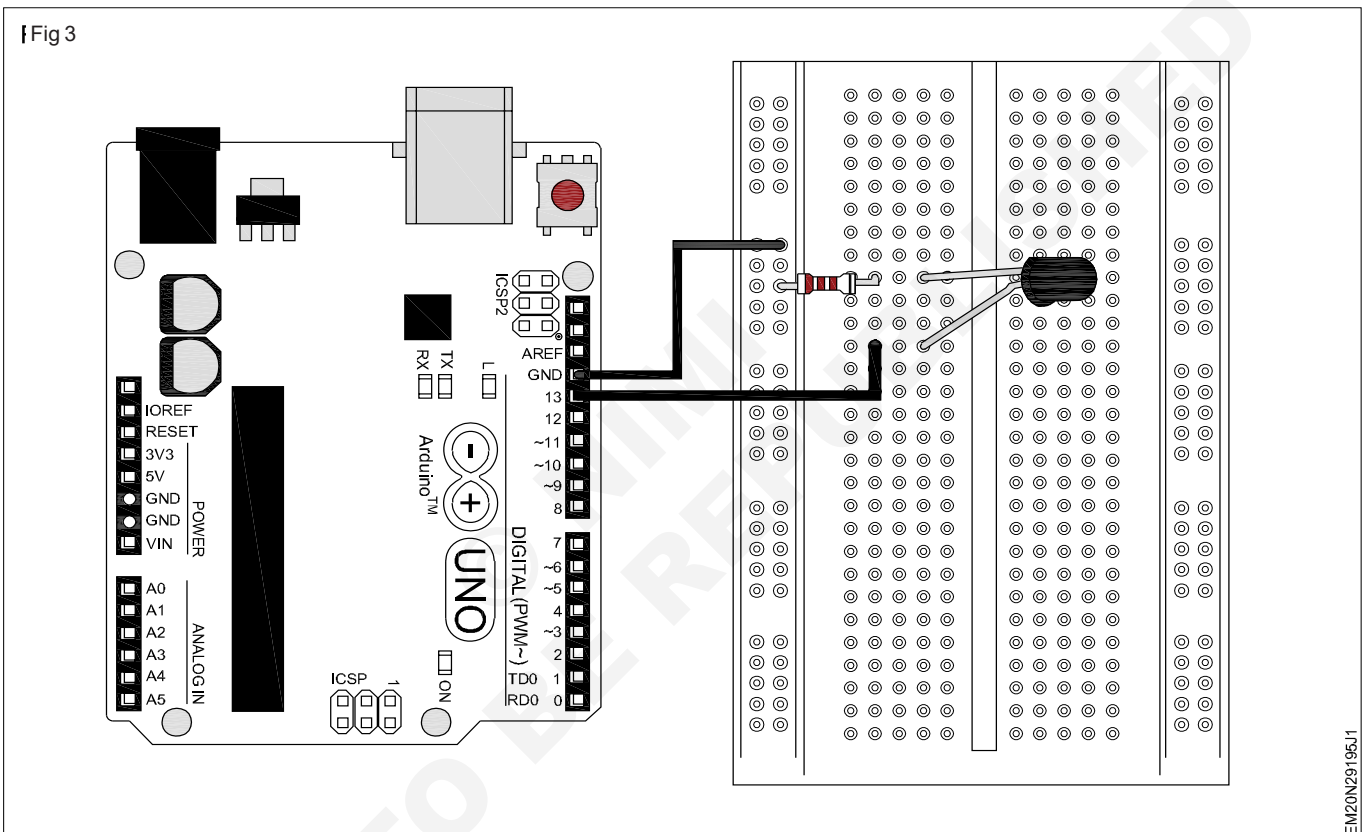
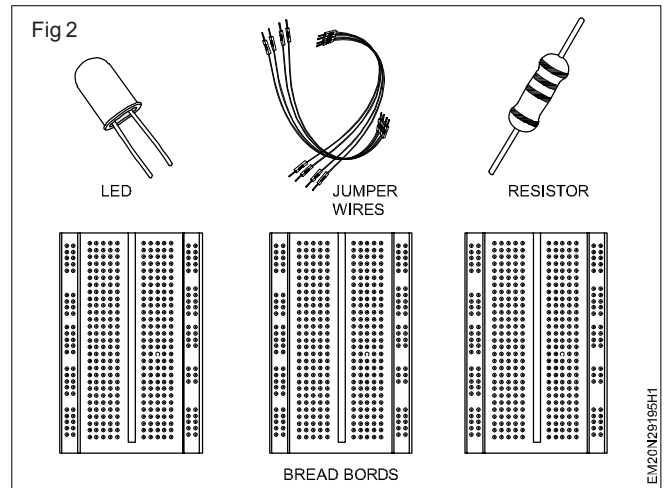

**Write and upload computer code to the physical Micro controller to sound buzzer**

**Objectives:** At the end of this exercise you shall be able to

- to connect buzzer and give power supply
- to observe the performance of sketch and actuation.

Requirements	
<b>Tools/Instruments/Equipments</b>	
<ul style="list-style-type: none"> <li>• Microcontroller Arduino uno board</li> <li>• Buzzer</li> <li>• Resistor</li> </ul>	<ul style="list-style-type: none"> <li>• PC with Arduino IDE installed</li> <li>• Jumper Wires</li> <li>• Breadboard</li> </ul>

**PROCEDURE**

**TASK 1 : Connect buzzer and give power supply and observe the performance**

- 1 Based on previous exercises 2.9.194 and 2.9.195, the additional component introduced here is buzzer as shown in Fig 1

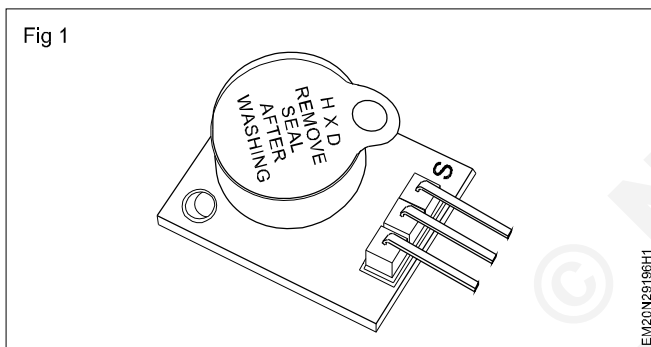

- 2 Interface buzzer with Arduino as shown in the Fig 2.

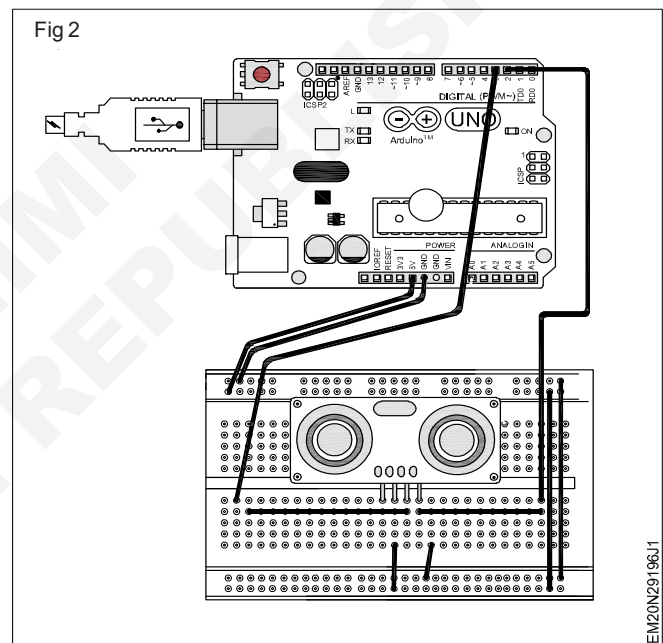

**TASK 2 : Observe the performance with code**

- 1 Type the code given below

```
intbuzzerPin=11;.....// initializing the buzzer
pin at pin 11 of Arduino
voidsetup(){.....// Code written in it
will only run once
pinMode(buzzerPin,OUTPUT);.....// This
will set the pin 11 as output
beep(50);.....// This will make a
beep sound Beep

beep(50);
delay(1000);.....//Adding a delay of 1
sec.
}
voidloop(){.....// Code written in it will
run continuously
```

```
beep(50);.....// This will make a beep
sound after every 500 milliseconds
delay(1000);.....// Adding a delay of one
second.
}
voidbeep(unsignedchar delays){.....// Created
a function for beep
analogWrite(buzzerPin,20);.....// This will
set pin 11 to high
.delay(delays);.....// Giving a
delay
analogWrite(buzzerPin,0);.....// This will
set pin 11 to LOW
delay(delays);.....// Giving a
delay
}
```

- 2 Upload the code and observe the actuation



## Circuit and program to Interface light sensor – LDR with Microcontroller to switch ON/OFF LED based on light intensity

**Objectives:** At the end of this exercise you shall be able to

- to connect LDR and to give power supply also type code.

### Requirements

#### Tools/Instruments/Equipments

- Microcontroller Arduino uno board
- LED
- 10k and 220 Ohm Resistor
- PC with Arduino IDE installed
- Jumper Wires

### PROCEDURE

**TASK 1 : Connect LDR and LED and also type code as shown below (Fig 1 & 2)**

- 1 LDR sensor to A1 pin of Arduino and connecting the second pin of LDR sensor to 5V pin of arduino

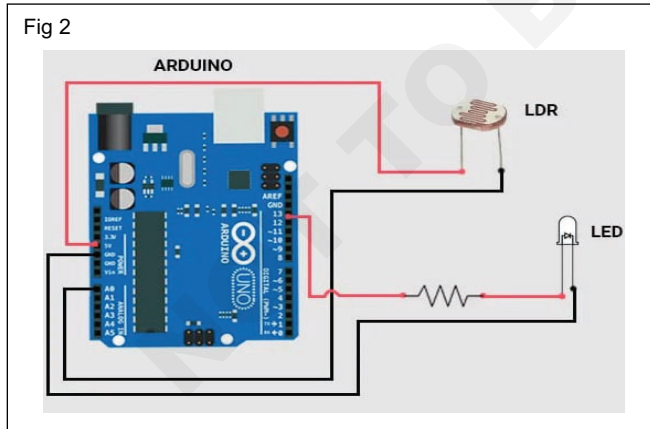
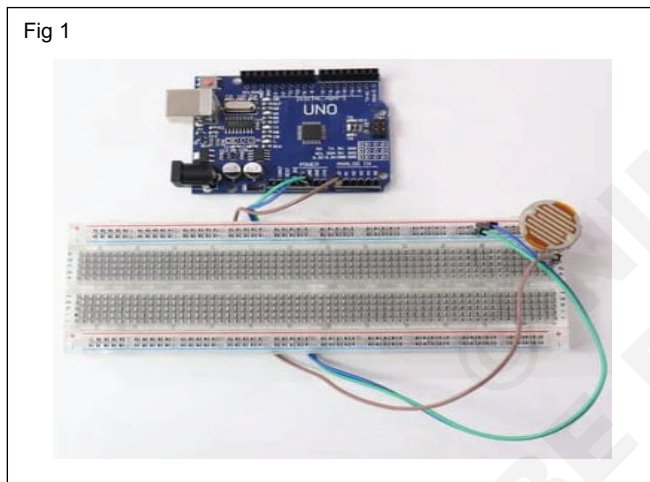

- 2 Type the code as shown below

Code :

```
const int ledPin = 13;
const int ldrPin = A0;
void setup(){
  Serial.begin(9600);
  pinMode(ledPin, OUTPUT);
  pinMode(ldrPin, INPUT);
}
void loop(){
  int ldrStatus = analogRead(ldrPin);
  if (ldrStatus <= 200) {
    digitalWrite(ledPin, HIGH);
    Serial.print("Its DARK, Turn on the LED : ");
    Serial.println(ldrStatus);
  } else {
    digitalWrite(ledPin, LOW);
    Serial.print("Its BRIGHT, Turn off the LED : ");
    Serial.println(ldrStatus);
  }
}
```

- 3 Observe the Output.

**Set up & test circuit to interface potentiometer with microcontroller and map to digital values for e.g. 0-1023**

**Objectives:** At the end of this exercise you shall be able to

- to connect potentiometer and to give power supply
- to observe the performance of circuit.

**Requirements**

**Tools/Instruments/Equipments**

- Arduino uno board
- Buzzer
- Breadboard
- PC with Arduino IDE installed
- Jumper Wires
- Breadboard

**PROCEDURE**

**TASK 1 : Connect potentiometer and give power supply**

- 1 Take a Potentiometer as show in Fig 1
- 2 Observer the circuit given in Fig 2

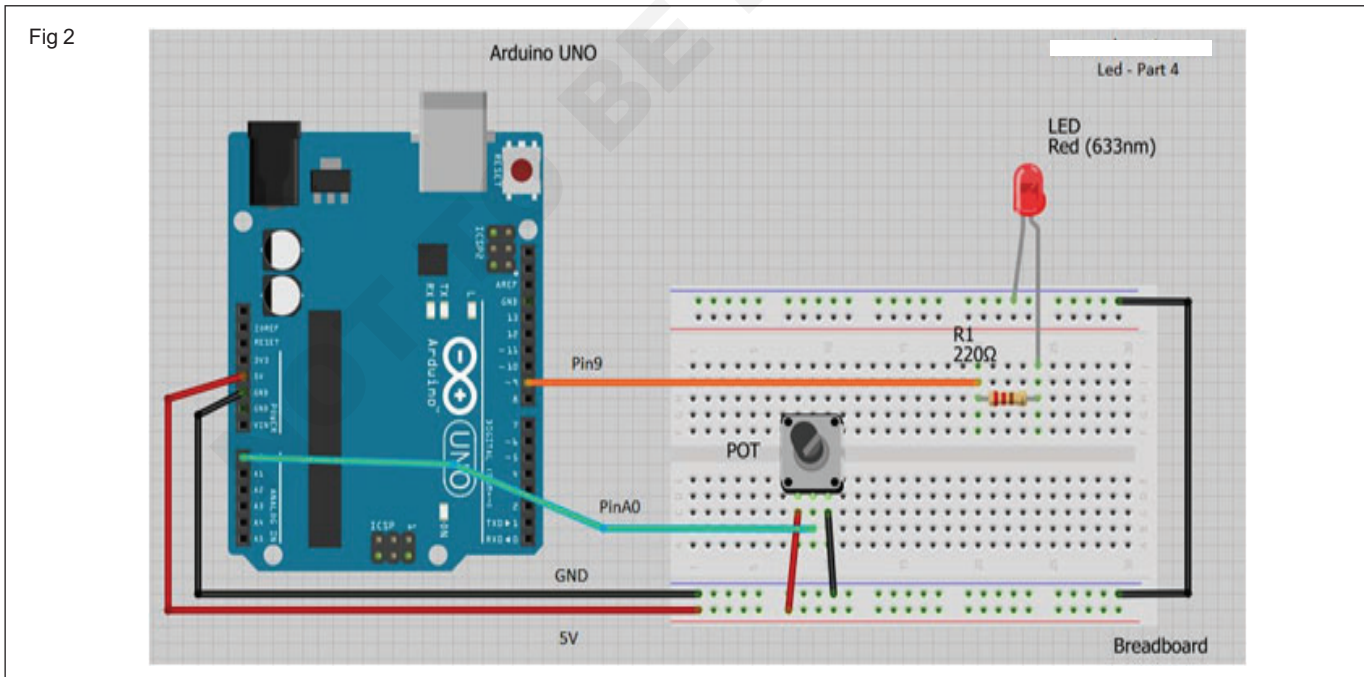
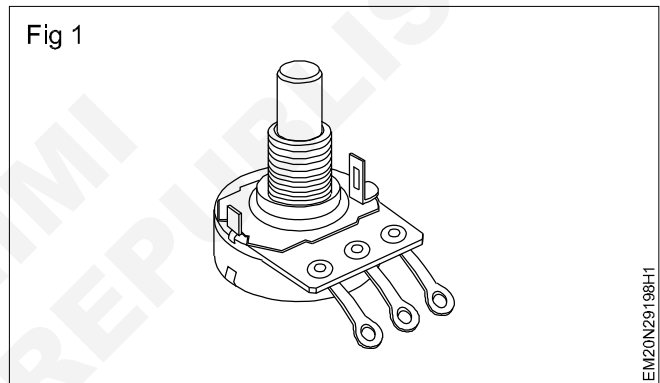

**TASK 2 : Observe the performance of circuit with code**

1 Connect setup, type the below code

```
//Constants:
const int ledPin = 9; //pin 9 has PWM funtion
const int potPin = A0; //pin A0 to read analog input
//Variables:
int value; //save analog value
void setup(){
  //Input or output?
  pinMode(ledPin, OUTPUT);
  pinMode(potPin, INPUT); //Optional
```

```
}
void loop(){
  value = analogRead(potPin); //Read and save
  analog value from potentiometer
  value = map(value, 0, 1023, 0, 255); //Map value 0-1023
  to 0-255 (PWM)
  analogWrite(ledPin, value); //Send PWM value to
  led
  delay(100); //Small delay
}
2 Observe the Output.
```

© NIMI  
NOT TO BE REPUBLISHED

**Identify the resources and their need on the given fiber optic trainer kit**

**Objectives:** At the end of the exercise you shall be able to

- identify different cables used in OFC
- identify different connectors used in OFC
- identify various sections in the OFC trainer kit.

Requirements	
<b>Tools/ Equipments/ Instruments</b> <ul style="list-style-type: none"> <li>• Optical fiber trainer kit with Instruction manual - 1 Set.</li> </ul>	<b>Materials/ Components</b> <ul style="list-style-type: none"> <li>• Assorted OFC cables - as reqd.</li> <li>• Assorted OFC connectors - as reqd.</li> <li>• OFC data manual - as reqd.</li> </ul>

**Note :** The instructor has to label the OFC cables used for this task and also for the OFC connectors.

**PROCEDURE**

**TASK 1 : Identify different cables used in OFC**

- 1 Pick any one of the labelled optical fiber cable from the given assorted cables.
- 2 Identify the name/type of cables used by referring to the data manual.
- 3 Record the name and its application in the TABLE 1.
- 4 Repeat above steps for all other labelled cables.

**Table 1**

Sl. No.	Name/Type of the cable	Application

**TASK 2 : Identify different connectors used in OFC**

- 1 Pick any one of the connector from the given assorted OFC connectors.
- 2 Identify the name / type of connectors by referring the data manual used in OFC.
- 3 Record the name and its application in the TABLE 2.
- 4 Repeat above steps for all other connectors.

**Table 2**

Sl. No.	Name/Type of the cable	Application



**Make optical fiber set up to transmit and receive analog and digital data**

**Objectives:** At the end of the exercise you shall be able to

- prepare the set-up of optical fiber trainer kit to transmit and receive analog signal
- prepare the set-up of optical fiber trainer kit to transmit and receive digital signal
- input and output (I/P and O/P) waveform viewing.

Requirements			
Tools/Equipments/Instruments		Materials/ Components	
• Optical fiber trainer kit with Instruction manual	- 1 Set.	• OFC cables	- as reqd.
• CRO 20 MHz (Dual trace) with probe kit	- 1 No.	• Patch cords	- as reqd.
• Trainees tool kit	- 1 Set.	• OFC data manual	- as reqd.
• Digital multimeter with probes	- 1 No.		

**PROCEDURE**

**TASK 1 : Setting up of optical fiber trainer kit to transmit and analog receive signal**

- 1 Check and confirm the given trainer kit is in working condition. (Fig 1)
- 2 Use patch cord and connect the function generator 1kHz/1V<sub>p-p</sub> sine wave output to input of photo emitter circuit input as shown in Fig 1 (Emitter circuit converts electrical input into light/ optical output).
- 3 Use the optical fiber cable and connect between photo emitter circuit output and input of photo detector circuit. (Photo detector circuit converts the light input into electrical output Fig.2)
- 4 Connect the output of photo detector circuit to AC amplifier input using patch cord.
- 5 Connect the function generator output to CH1 and amplifier output to CH2 of CRO.
- 6 Turn the mode selector switch SW1 in the photo emitter circuit to analog mode.
- 7 Switch ON the trainer kit and prepare CRO for measurement.
- 8 Observe and trace the analog signal at CH1 and transmitted output signal at CH2 of CRO.
9. Modify the connection of CH1 of CRO to photo detector output, and observe the output signal of photo detector circuit.
- 10 Record the observed waveforms in the TABLE 1 and compare with the amplifier output signal.

**If the input and output waveforms are same, optical link has been established between the transmitter and the receiver.**

Table 1

Photo emitter input Signal waveform	Photo detector output signal waveform	AC amplifier output - V <sub>p-p</sub>

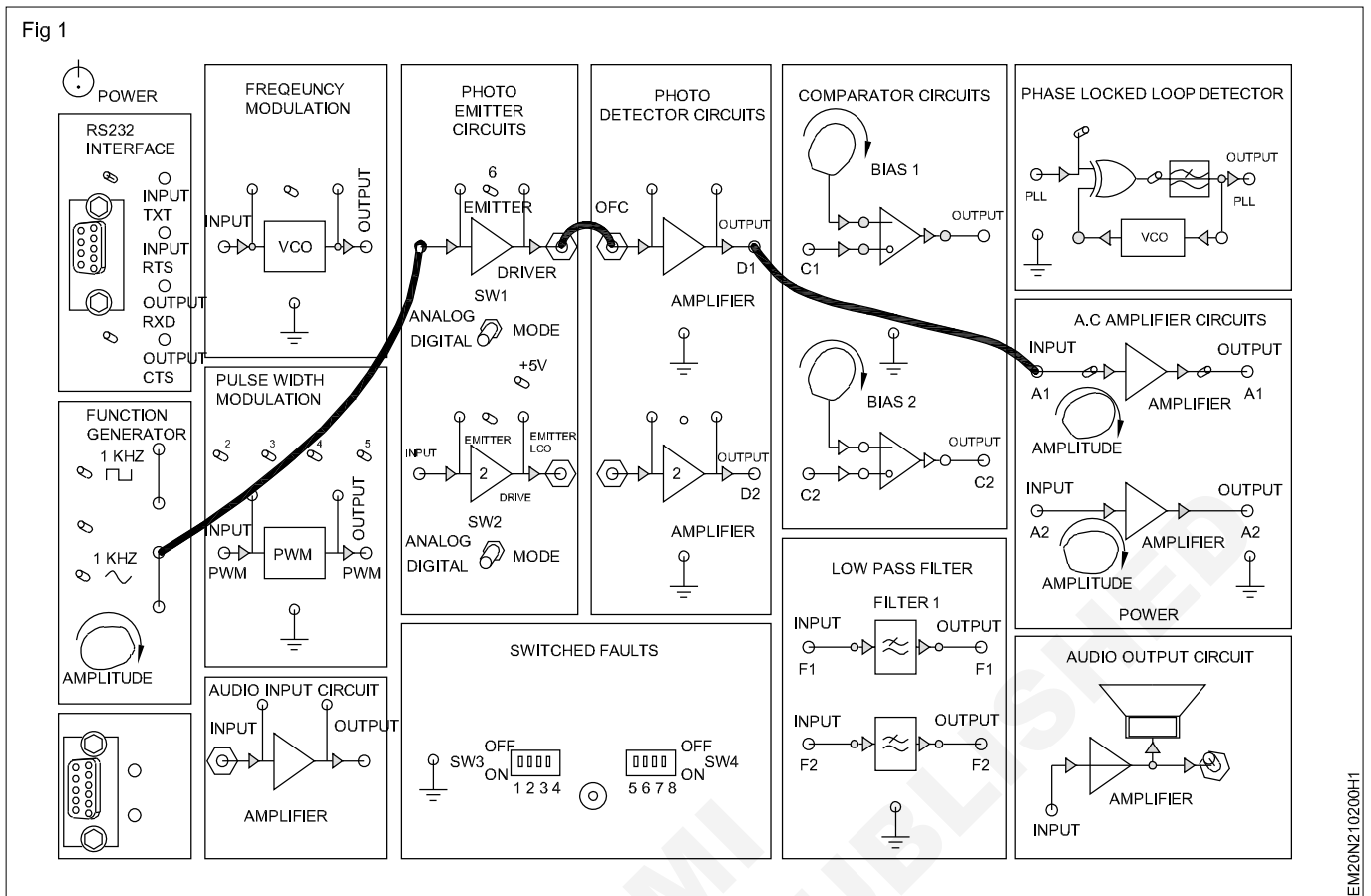

EM20N210200H1

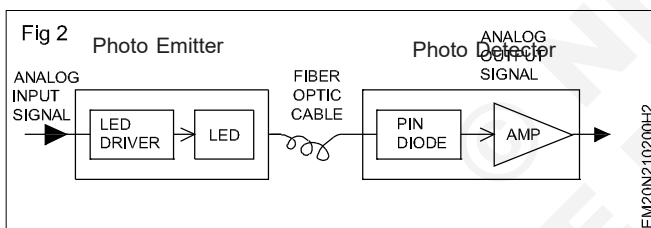

EM20N210200H2

11 Get the work checked by the instructor.

## TASK 2 : Setting up of optical fiber trainer kit to transmit and receive and digital signal

- 1 Check and confirm the given trainer kit is in working condition. (Fig 1) & (Fig 2)
- 2 Use patch cord and connect the function generator 1kHz/1V<sub>p-p</sub> square wave output to the input of photo emitter input as shown in Fig 1.
- 3 Use the optical fiber cable (OFC) and connect output of photo emitter circuit to the input of photo detector circuits as shown in Fig1.
- 4 Use patch cord and connect the detector circuit's output to the input of comparator circuits; connect the comparator circuits output to AC amplifier input using patch cord
- 5 Connect the function generator output to CH1 and amplifier output to CH2 of CRO.
- 6 Get the circuit connections checked by the instructor.
- 7 Turn the mode selector switch SW1 in the photo emitter circuit to digital.
- 8 Switch ON the trainer kit and prepare the CRO for measurement. Modify the connection of CH1 of CRO to photo detector output and observe the signal waveform.
- 9 Now connect CH1 of CRO to comparator output and observe the (received digital) output signal of comparator.
- 10 Observe and trace the digital square wave Input at CH1 and output signal at CH2 on CRO.
- 11 Record the observed waveforms in TABLE 2 and compare with the amplifier output signal.

**If the input and output waveforms are same, optical link has been established between the transmitter and the receiver.**

Table 2

Photo Emitter input signal waveform	Photo detector Output signal waveform	AC amplifier Output waveform

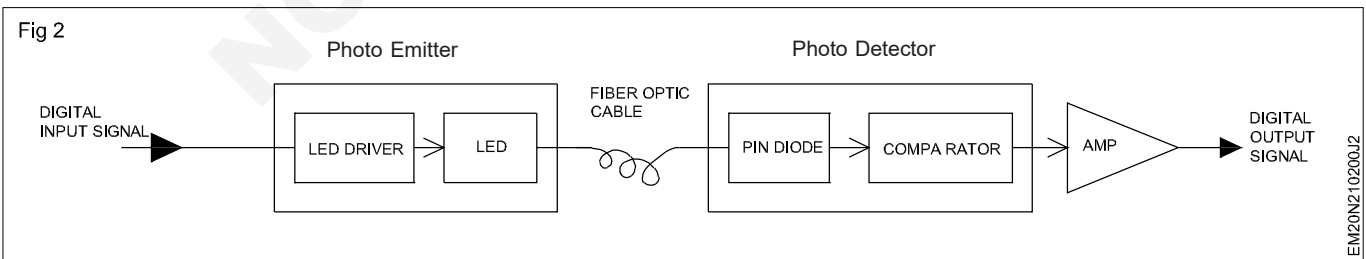
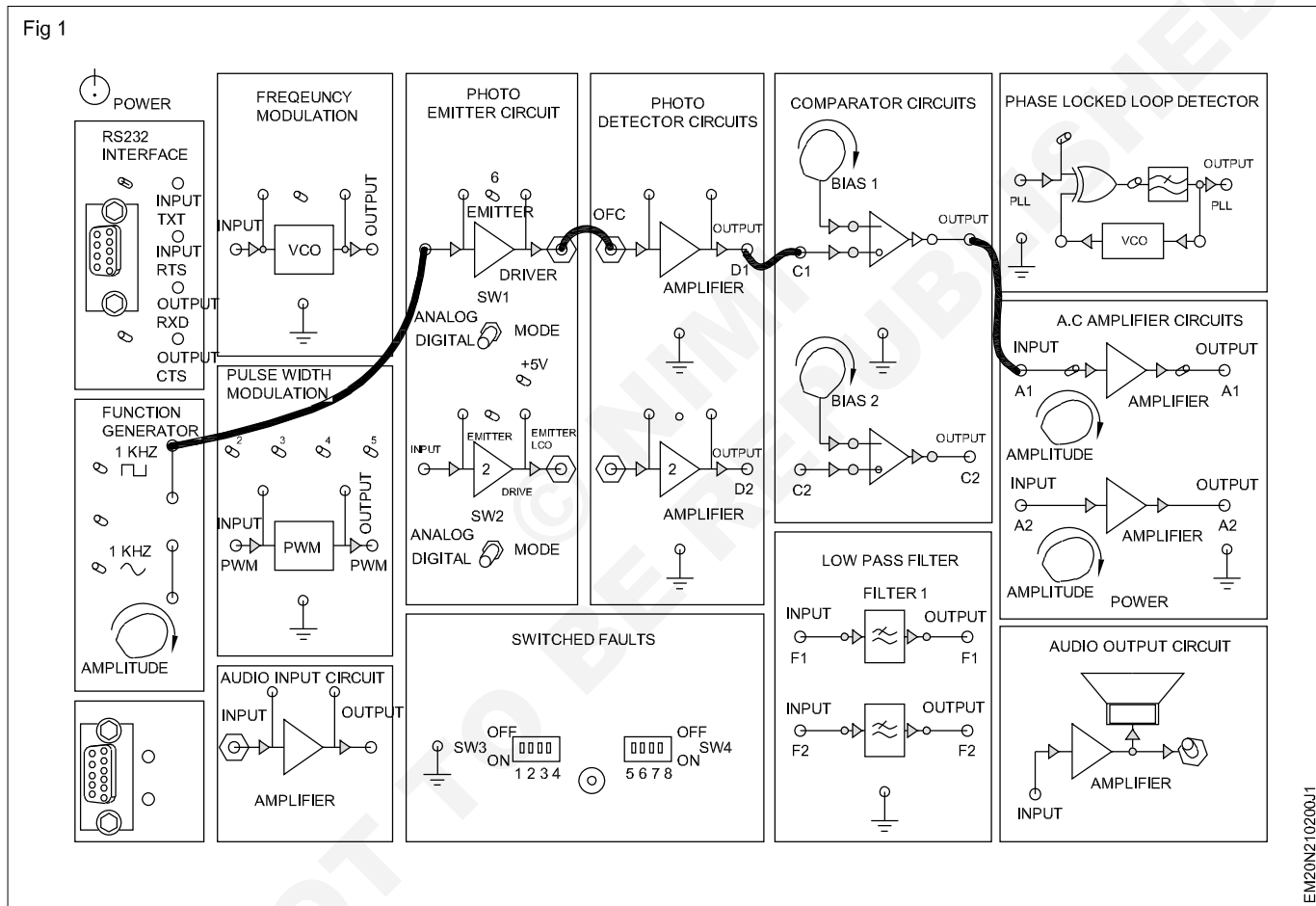

13 Get the work checked by the Instructor.



**Set up the OFC trainer kit to study AM, FM, PWM modulation and demodulation**

**Objectives:** At the end of the exercise you shall be able to

- demonstrate amplitude modulation and demodulation using OFC trainer kit
- demonstrate frequency modulation and demodulation using OFC trainer kit
- demonstrate pulse width modulation and demodulation using OFC trainer kit.

Requirements			
<b>Tools/Equipments/Instruments</b>			
• Optical fiber trainer kit with instruction manual	- 1 Set.	• Loud speaker/ Head phone	- 1 No.
• CRO 20 MHz (Dual trace) with probe kit	- 1 No.	• AM/FM signal generator	- 1 No.
• Trainees tool kit	- 1 Set.	<b>Materials/ Components</b>	
• Digital multimeter with probes	- 1 No.	• OFC cable	- 1 No.
• Microphone(Dynamic)	- 1 No.	• Patch cords	- as reqd.
		• OFC data manual	- as reqd.

**PROCEDURE**

**TASK 1 : Setting up of amplitude modulation and demodulation using OFC trainer kit**

- 1 Check and confirm the OFC trainer kit is in working condition.
- 2 Make the connections as shown in figure 1.

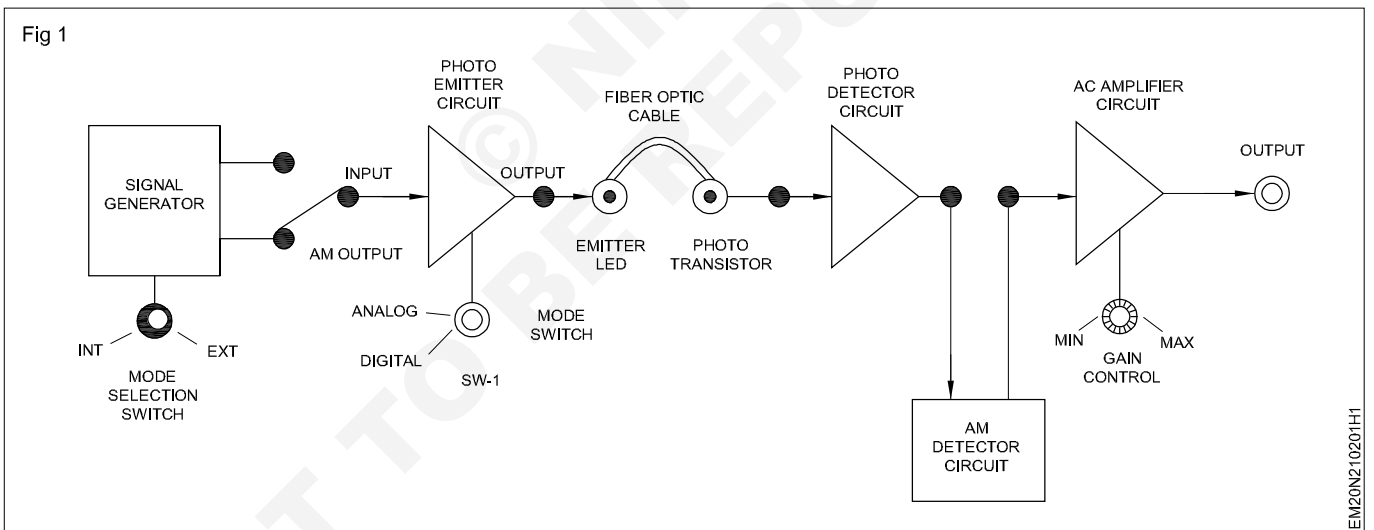

- (a) Use patch cord, connect the signal generator AM wave output to the photo emitter input.
  - (b) Use and connect the fiber optic cable between photo emitter output and photo detector input.
  - (c) Connect the photo detector output to AM detector circuit. Connect the AM detector output to AC amplifier input.
- 3 Turn the mode selector switch SW1 of photo emitter to the analog mode.
  - 4 Get the connections made for AM modulation set up checked by the instructor.
  - 5 Switch ON the power supply of the trainer kit and prepare Oscilloscope for measurements.

- 6 Set the AM mode selection of the signal generator to internal mode.
- 7 Observe the input and output signal waveform on oscilloscope record them in Table - 1.

**Table 1**

Sl. No.	Name of the section	Input/output Waveform	Remarks

8 Get the work checked by the instructor.

**TASK 2 : Setting up of frequency modulation and demodulation using OFC trainer kit**

- 1 Check and confirm the OFC trainer kit is in working condition. (Fig 1)
- 2 Note down the sections of the OFC trainer kit in the Table 1.

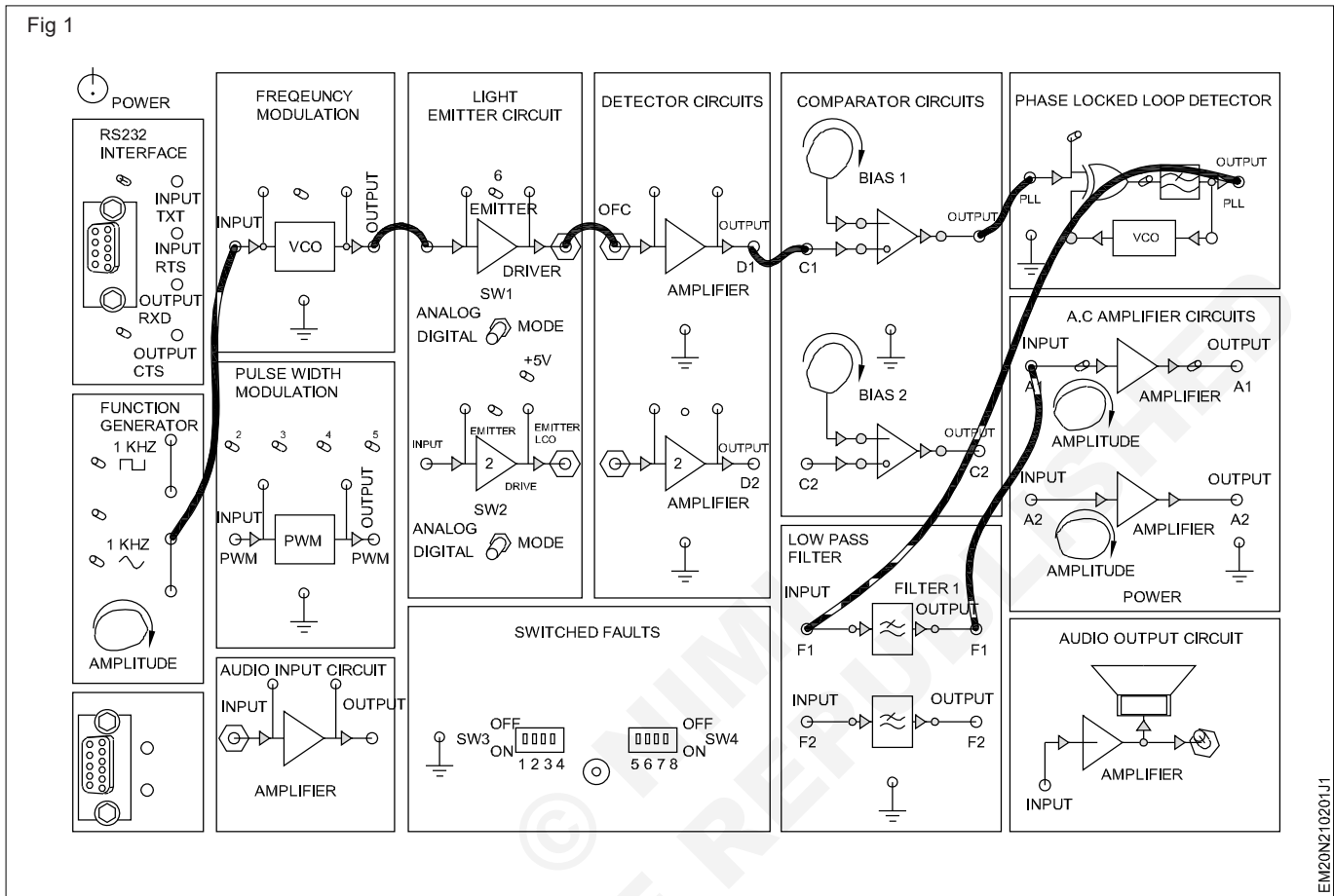

- 3 Use OFC cable, connect the input of function generator to the input of FM modulator section.
- 4 Use OFC cable, connect the output of light emitter circuit to FM detector input terminal.

**Note: The instructor may follow the step as per the trainer kit available in the section.**

- 5 Use patch cords, connect the detector output to the input of comparator.
- 6 Connect the comparator output to PLL detector input. and connect PLL detector output to low pass filter input.
- 7 Connect low pass filter output to AC amplifier input as shown Fig 1 and Fig 2.
- 8 Prepare the CRO for measurement and connect the function generator output to channel - 1 and amplifier output to the channel -2 of CRO.
- 9 Switch ON power and set the function generator for 1 kHz/1  $V_{p-p}$  Sine wave signal output.

- 10 Set the mode selector switch SW1 in the emitter circuit to analog mode and observe the input and output signals on CRO; record the observation in Table 2.
- 11 Repeat the step 11 & 12 with mode switch set at digital position.

**Table 2**

Mode switch position	i/p signal $V_{p-p}$	Wave form	Output signal $V_{p-p}$	Wave form
Analog				
Digital				

Fig 2

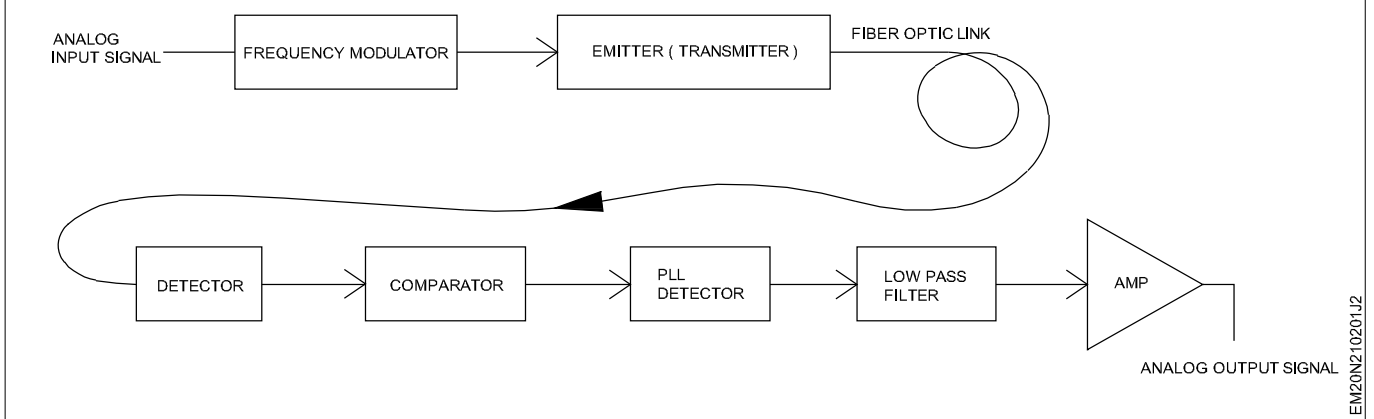

EM20N210201J2

12 Get the work checked by the Instructor.

-----

**TASK 3 : Setting up of pulse width modulation and demodulation using OFC trainer kit**

- 1 Check and confirm the OFC trainer kit is in working condition. (Fig 1)
- 2 Set the function generator to 1 kHz/1V<sub>p-p</sub> sine wave signal output.
- 3 Use patch cords and connect
  - the function generator to the input of pulse width modulator;
  - pulse width modulator output to the light emitter circuits input.
  - Use the OFC cable between emitter circuits output and detector circuits input.
- 4 Connect the function generator output & amplifier output to the CH-1 and CH-2 of CRO.
- 5 Turn the mode selector switch in the emitter circuits to digital mode.
- 6 Switch ON the trainer kit and CRO.
- 7 Observe and trace the input and output signal on CRO; record the observations in Table 3

**Table 3**

Mode switch position	Emitter circuit Input signal V <sub>p-p</sub>	Waveform	A/C amplifier output signal V <sub>p-p</sub>	Waveform	Remark
Digital mode					

Fig 1

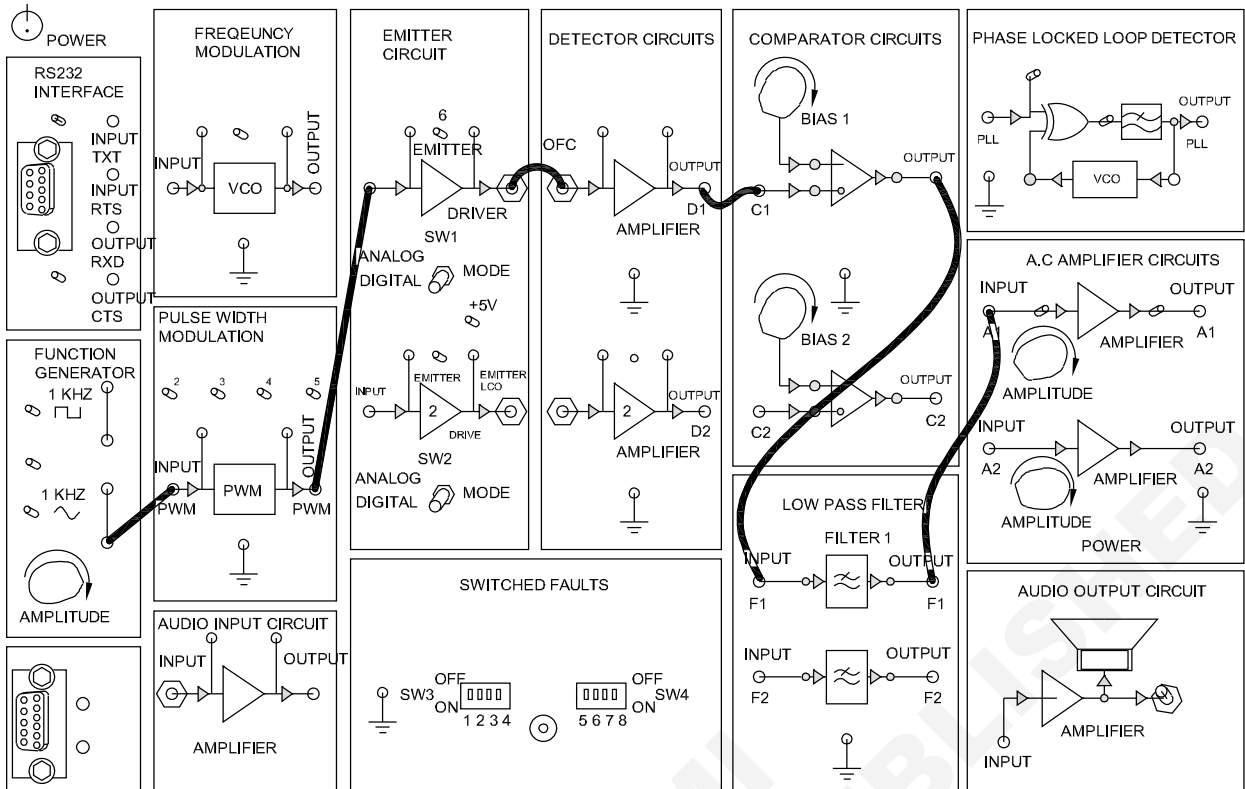

EM20N210201X1

8 Get the work checked by the Instructor.

**Perform FM modulation and demodulation using OFC trainer kit using audio signal and voice link**

**Objectives:** At the end of the exercise you shall be able to

- demonstrate frequency modulation and demodulation using OFC trainer kit by audio signal
- demonstrate frequency modulation and demodulation using OFC trainer kit by voice link signal.

Requirements	
Tools/Equipments/Instruments	Materials/ Components
<ul style="list-style-type: none"> <li>• Optical fiber trainer kit with instruction manual - 1 Set.</li> <li>• CRO 20 MHz (Dual trace) with probe kit - 1 No.</li> <li>• Trainees tool kit - 1 Set.</li> <li>• Digital multimeter with probes - 1 No.</li> <li>• Microphone(Dynamic) - 1 No.</li> <li>• Loud speaker/ Head phone - 1 No.</li> <li>• Audio signal source - 1 No.</li> </ul>	<ul style="list-style-type: none"> <li>• OFC cables - 1 No.</li> <li>• Patch cards - as reqd.</li> <li>• OFC data manual</li> <li>3.5 mm stereo EP to EP cable - 1 No.</li> <li>6 mm to 3.5 mm phono adapter - 1 No.</li> </ul>

**PROCEDURE:**

**TASK 1 : Frequency modulation and demodulation of audio signal using OFC trainer kit**

- 1 Check and confirm the OFC trainer kit is in working condition. (Fig 1) & (Fig 2)
- 2 Use patch cords and connect the audio amplifier output to the input of frequency modulator; frequency modulator output to the emitter input.
- 3 Use OFC cable connect it between photo emitter output and photo detector's input; connect photo detector output to comparator input using patch cord.
- 4 Use patch cord and connect the comparator output to PLL detector input; PLL detector output to low pass filter input and low pass filter output to AC amplifier input. (Fig 2)
- 5 Connect the audio signal output to the input of audio input amplifier.
- 6 Put the mode switch SW1 in the emitter circuit to digital mode.
- 7 Prepare the CRO for measurements and switch ON the trainer kit.
- 8 Observe the input output signals on CRO and record them in Table 1.
- 9 Get the work checked by the instructor.

**Note: The instructor has to provide audio signal from any available signal sources like/CD player/mobile phone - connect audio signal source to the input amplifier.**

**Table 1**

Mode switch position	Frequency modulator input signal $V_{p-p}$	Waveform	AC amplifier output signal $V_{p-p}$	Waveform

Fig 1

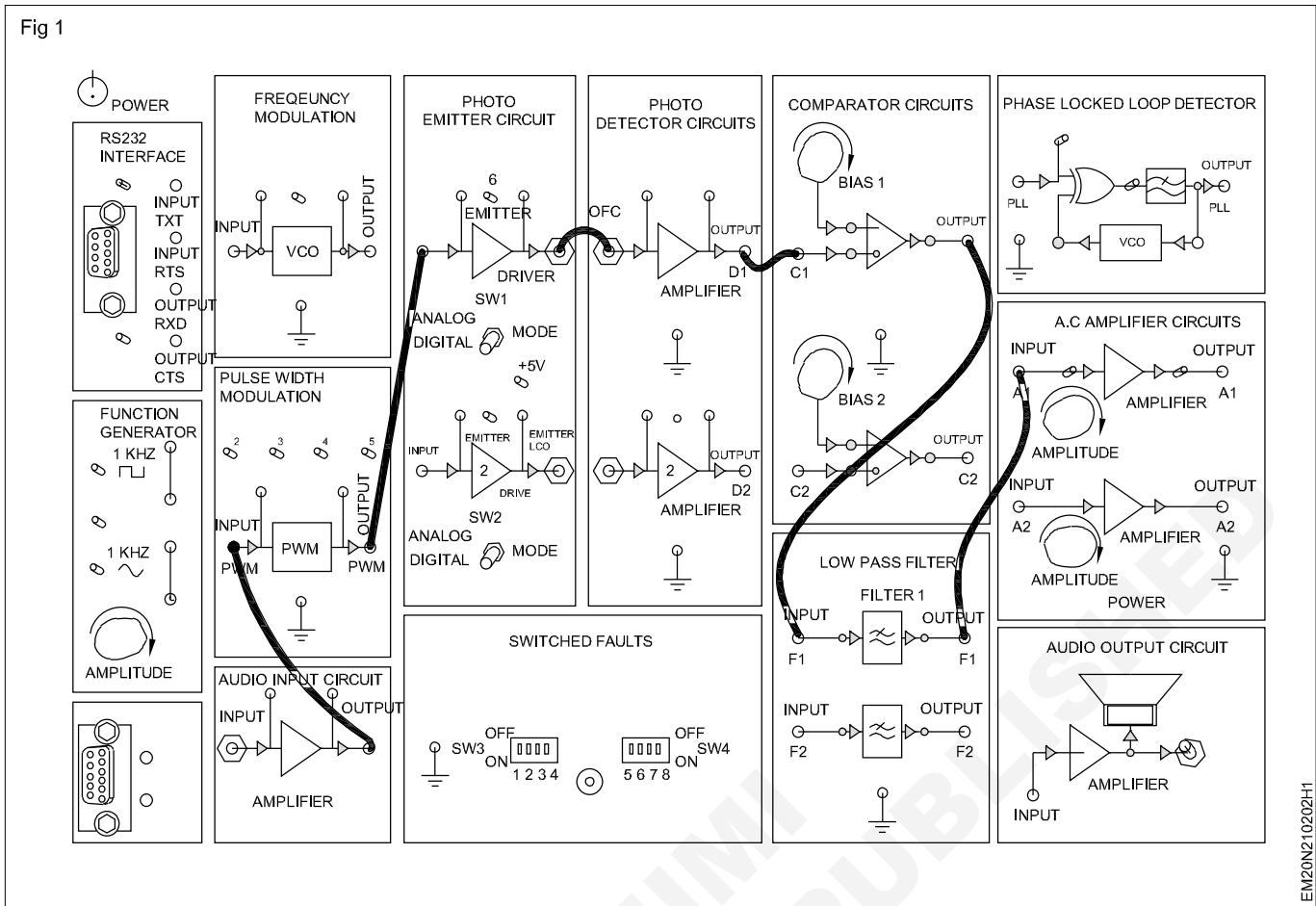

EM20N2:10202H1

Fig 2

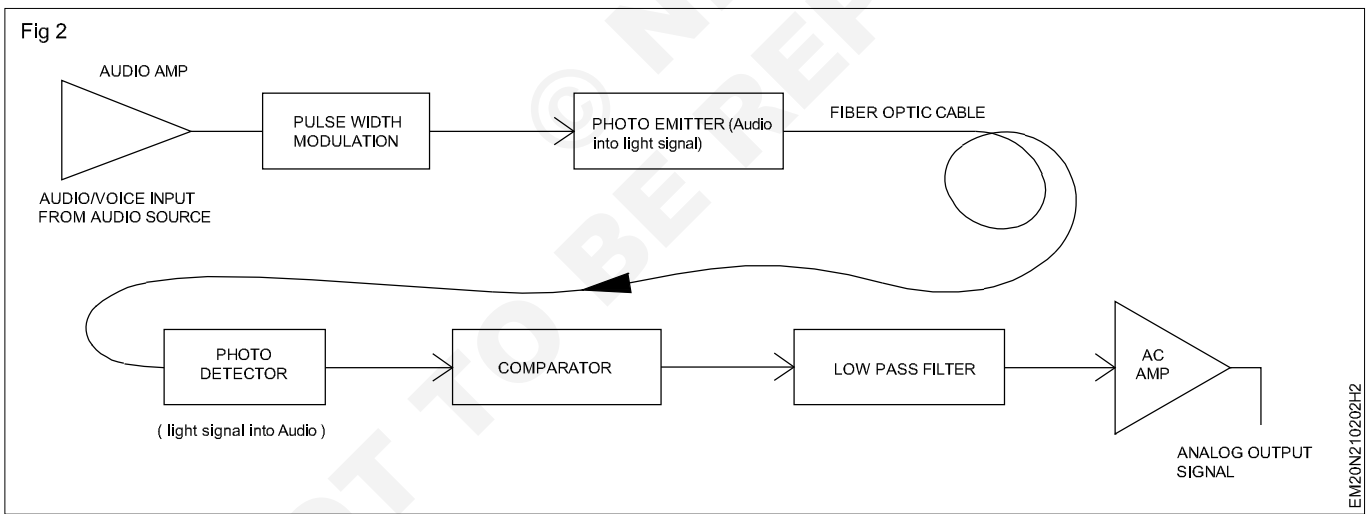

EM20N2:10202H2

**TASK 2 : Frequency modulation and demodulation of voice link signal using OFC trainer kit**

- 1 Keep the settings/ connections as per steps 1 to 4 of TASK 1.
- 2 Disconnect the audio signal and CRO from the circuit.
- 3 Using the phone adapter connect the external microphone into the input of audio input circuit.
- 4 Use patch cord and connect the output of audio input circuit to input of frequency modulator; use OFC cable, connect between emitter circuit and input of detector circuit, upto AC amplifier as shown in Fig 1 and 2.
- 5 Connect the Ac amplifier output to the input of the audio output circuit (Louds speaker).

**If built-in speaker is not available connect speaker or headphone externally to audio output block.**

- 6 Switch ON the trainer kit, speak in the microphone and listen to the speech sound through the loudspeaker/ headphone.
- 7 Get the work checked by the Instructor.

**Perform PWM modulation and demodulation using OFC trainer kit using audio signal and voice link**

**Objectives :** At the end of this exercise you shall be able to

- demonstrate pulse width modulation and demodulation using OFC trainer kit by using analog signal
- demonstrate pulse width modulation and demodulation using OFC trainer kit by using voice link signal.

Requirements	
<b>Tools/Equipments/Instruments</b>	<b>Materials/Components</b>
<ul style="list-style-type: none"> <li>• Optical fiber trainer kit with instruction manual - 1 Set.</li> <li>• CRO 20 MHz (Dual trace) with probe kit - 1 No.</li> <li>• Trainees tool kit - 1 Set.</li> <li>• Digital multimeter with probes - 1 No.</li> <li>• Microphone(Dynamic) - 1 No.</li> <li>• Loud Speaker/ Head phone - 1 No.</li> <li>• Audio signal source - 1 No.</li> </ul>	<ul style="list-style-type: none"> <li>• OFC cables - 1 No.</li> <li>• Patch cards - as reqd.</li> <li>• OFC data manual - 1 No.</li> <li>• 3.5mm stereo EP to EP cable - 1 No.</li> <li>• 6mm to 3.5mm phono adapter - 1 No.</li> </ul>

**PROCEDURE:**

**TASK 1 :Pulse Width Modulation of audio signal and demodulation using OFC trainer kit**

- 1 Check and confirm the OFC trainer kit is in working condition. (Fig 1)
- 2 Use patch cords and connect the audio signal source to the input amplifier; connect the audio input amplifier output to the input of pulse width modulator.
- 3 Connect the pulse width modulator output to the photo emitter circuits input using patch cord.
- 4 Use OFC cable between photo emitter circuits output and photo detector circuits input; connect the photo detector output to comparator circuits input, using patch cord.
- 5
- 6 Connect the input amplifier & output of AC amplifier to the CH 1 and CH 2 of CRO.
- 7 Turn the mode switch SW1 in the photo emitter circuits to digital mode.
- 8 Switch ON the trainer kit, prepare the CRO for measurements.
- 9 Observe the input and output signal on CRO and record them in Table - 1.

**Table 1**

Mode switch Position	PWM input Signal	Waveform	AC amplifier	Wavefrom

**Note: The instructor has to provide audio signal from any available signal source like CD/DVD player/Mobile phone.**

- 5 Use patch cords and connect comparator circuit and output to low pass filter input; low pass filter output to AC amplifier input as shown in Fig 2.

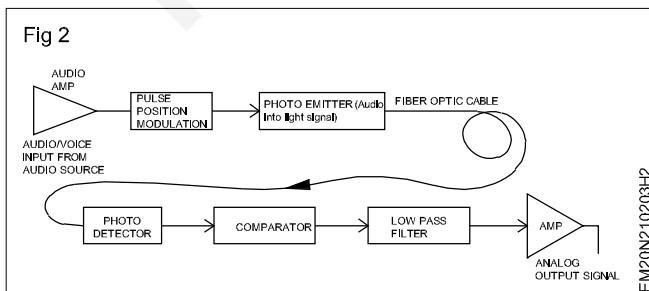

- 10 Get the work checked by the Instructor.

Fig 1

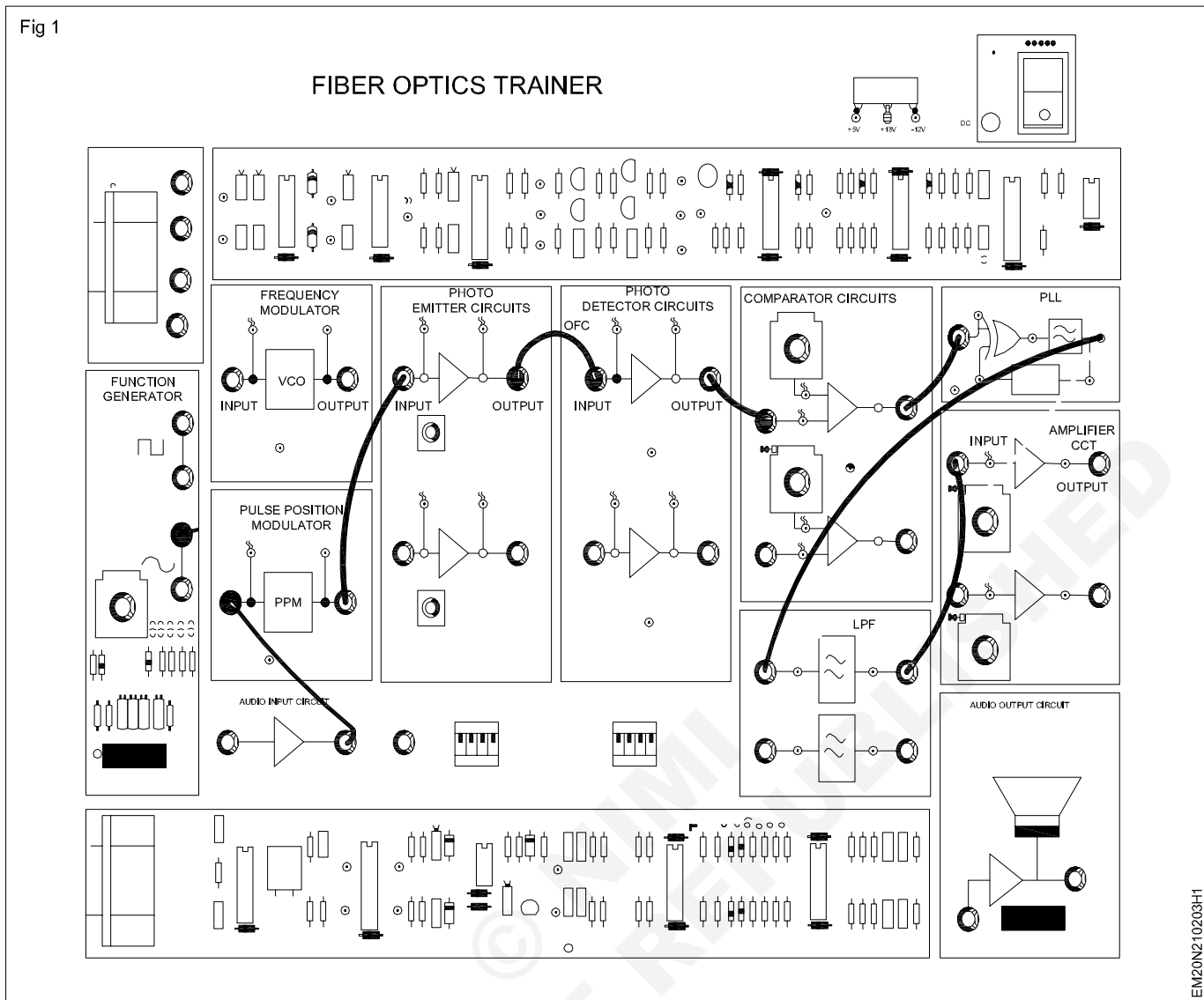

EM20N210203H1

**TASK 2 :Pulse width frequency Modulation of voice link signal and demodulation using OFC trainer kit.**

- 1 Keep the settings connections done in TASK 1.
- 2 Disconnect the audio signal source and CRO from the circuit.
- 3 Use the phono adapter and connect the external microphone into the input of audio input circuit.
- 4 Use patch cords, connect the output of audio input circuit to the input of pulse width modulator and photo emitter circuit.
- 5 Use OFC cable, connect between the photo emitter output to photo detector input.
- 6 Use patch cord connect the comparator, low pass filter and AC amplifier as shown in Fig 1 and 2.
- 7 Switch ON the trainer kit and speak in the microphone and listen the speech sound through the speaker / headphone.

**If built-in speaker is not available connect speaker or headphone externally to the audio output block.**

- 8 Get the work checked by the instructor.



**Perform PPM modulation and demodulation using fiber optic communication trainer kit using audio signal and voice link**

**Objectives:** At the end of the exercise you shall be able to

- Identify the different cables used in OFC demonstrate pulse position modulation and demodulation using audio signal
- Identify the different connectors used in OFC demonstrate pulse position modulation and demodulation using voice link signal.

<b>Requirements</b>			
<b>Tools/Equipments/Instruments</b>			
• Optical fiber trainer kit with instruction manual	- 1 Set.	• Audio signal source	- 1 No.
• CRO 20 MHz (Dual trace) with probe kit	- 1 No.	<b>Materials/ Components</b>	
• Trainees tool kit	- 1 Set.	• OFC cables	- 1 No.
• Digital multimeter with probes	- 1 No.	• Patch cards	- as reqd.
• Microphone(Dynamic)	- 1 No.	• OFC data manual	
• Loud Speaker/ Head phone	- 1 No.	• 3.5mm stereo EP to EP cable	- 1 No.
		• 6mm to 3.5mm phono adapter	- 1 No.

**PROCEDURE:**

**Note: The instructor has to provide audio signal from any available signal source like CD/DVD player mobile phone.**

**TASK 1 : Pulse Position Modulation and demodulation of audio signal using OFC trainer kit.**

- 1 Check and confirm the given OFC trainer kit is in working condition.
- 2 Use patch cords refer to Fig 1 and connect the audio signal source to the input amplifier; the function generator output to the input of Pulse Position Modulator and Pulse position modulator output to the photo emitter input as shown in Fig 1.
- 3 Use OFC cable, connect the photo emitter output to the input of photo detector; use patch cord and connect Photo detector output to comparator input.
- 4 Use patch cords, connect comparator output to PLL detector input; PLL detector output to low pass filter input and Low pass filter output to AC amplifier input as shown in Fig 1 & 2.
- 5 Connect the function generator output to Ch1 and amplifier output to Ch 2 of CRO inputs.
- 6 Set the mode selector switch to digital mode.
- 7 Prepare the CRO for measurements and switch ON the trainer kit.
- 8 Observe the input output signal on CRO and record in Table 1.

**Table 1**

Waveform at PPM input	Waveform at PPM Output	Waveform at Photo Detector output	Amplifier output

**Note: The instructor has to provide audio signal from any available signal source like CD/DVD player mobile phone etc.**

- 5 Connect the function generator output to Ch1 and amplifier output to Ch 2 of CRO inputs.

- 7 Get the work checked by the Instructor.

Fig 1

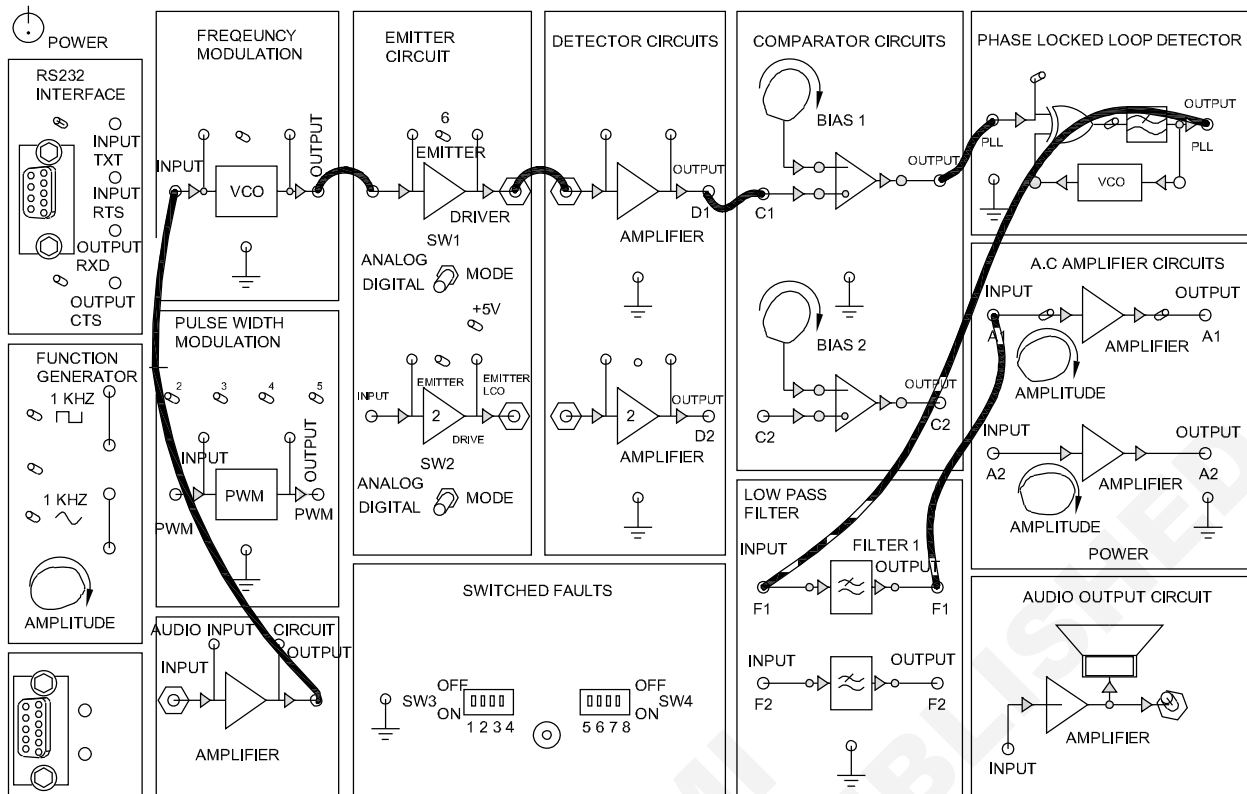

EM20N210204H1

Fig 2

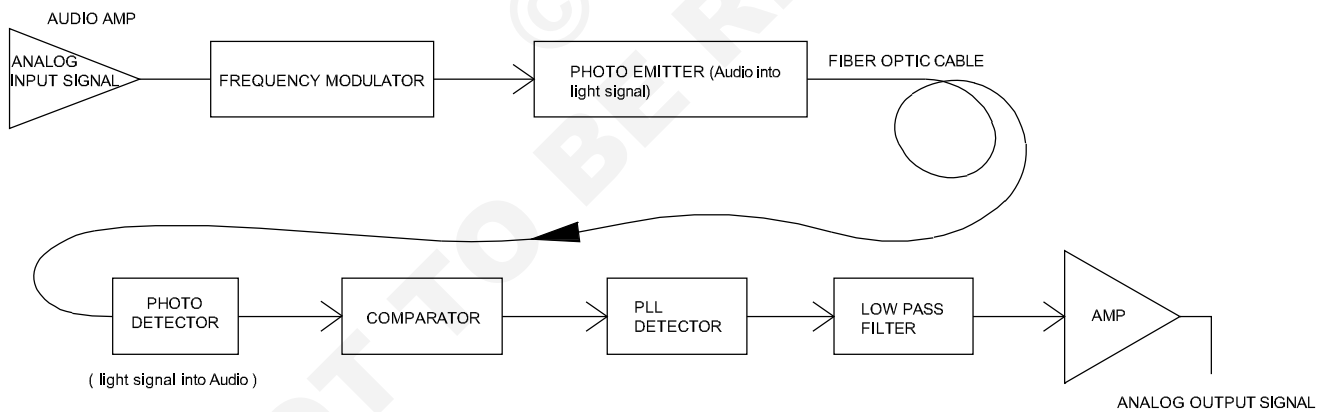

EM20N210204H2

**TASK 2 : Pulse Position Modulation and demodulation of voice link signal using OFC trainer kit.**

**If built-in speaker is not available connect speaker or headphone externally to the audio output block using patch cords.**

- 1 Keep the settings as same in TASK 1.
- 2 Disconnect the Audio signal source remove the Ch 1 & Ch 2 connections to the CRO.
- 3 Use the phono adapter and connect the microphone to the input of audio input circuit. Use patch cords,

connect the output of AC amplifier circuit to input of audio output circuit. (loudspeaker)

- 4 Get the circuit connections checked by the instructor.
- 5 Switch ON the trainer kit.
- 6 Speak in the microphone and listen to the speech sound through the speaker / Headphone.
- 7 Get the work checked by the Instructor.

Identify LED display module and its decoder/driver ICs

- Objectives:** At the end of the exercise you shall be able to
- identify the type of LED display used in the Digital Panel Meter
  - identify various decoder/driver IC in digital panel meter.

Requirements	
<b>Tools/Equipments/Instruments</b>	<b>Materials/ Components</b>
<ul style="list-style-type: none"><li>• Digital panel meter with different driver ICs - as reqd.</li><li>• Trainees tool kit - 1 Set.</li><li>• Digital Multimeter with probes - 1 No.</li></ul>	<ul style="list-style-type: none"><li>• Operating / Instruction manual</li></ul>

**Safety precaution**  
1 Keep the work area dry and clean.

2 Use proper tools for opening the Digital Panel Meter.

PROCEDURE

TASK 1 : Identification of the type of LED display

1. Pick any one of the labelled digital panel meter from the instructor
2. Note down the name plate details of the digital panel meter as shown in Fig 1.
3. Check the panel display type (LCD, LED, Dot matrix, etc.) and note down in Table-1.
4. Repeat the above steps for all other digital panel meter.

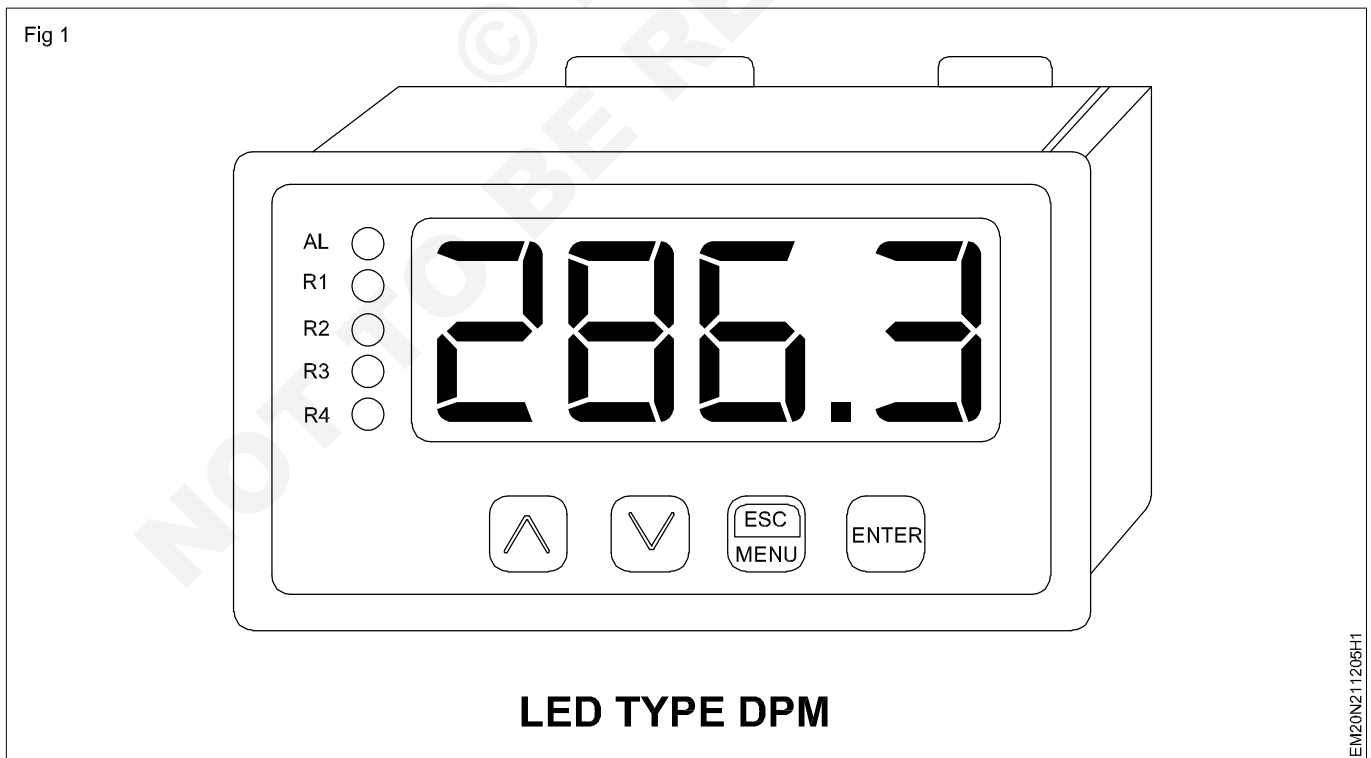

**TASK 2 : Identification of the Decoder/Driver IC in Digital Panel Meter**

1. Pick any one of the labelled digital panel meter from the instructor
2. Remove the back panel in the DPM.
3. Remove the circuit board in DPM cabinet.
4. Identify the type of circuit board & Decoder/Driver IC and record in Table by referring the block diagram Fig 1.
5. Repeat the above steps for all the panel meters and know the type of IC.

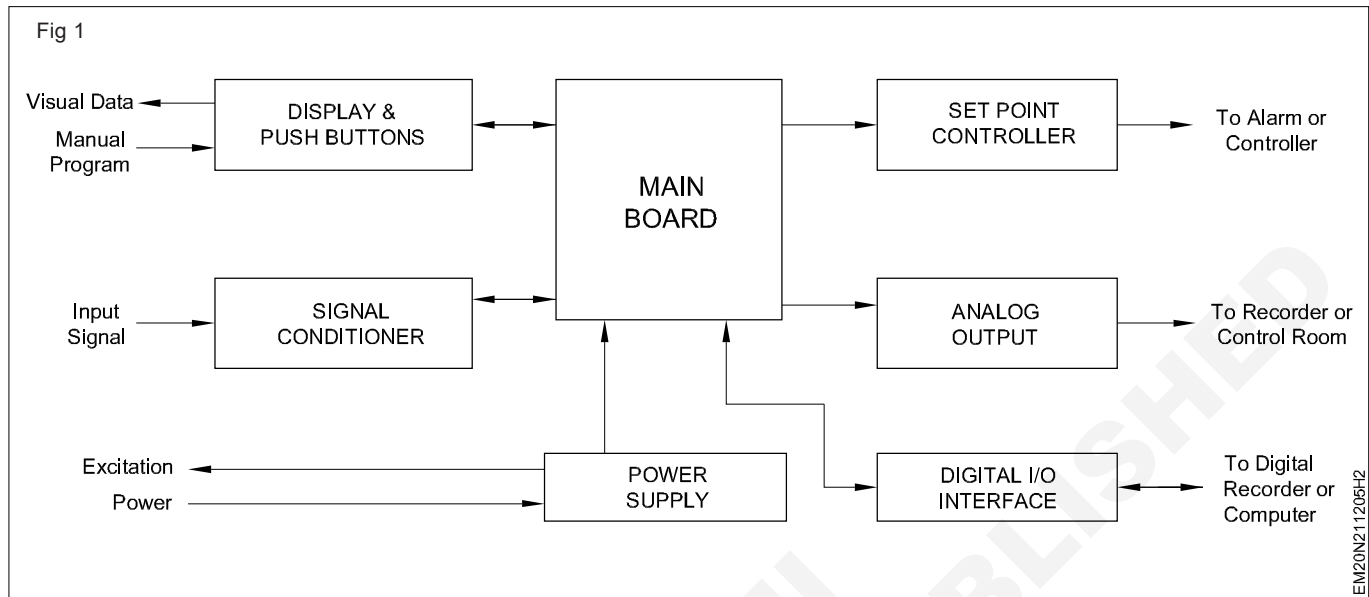

**Table -1**

Label No.	Name plate details of DPM	Display type	Display colour	Decoder/Driver IC

## Display a word on a two line LED

- Objectives:** At the end of the exercise you shall be able to
- construction of a two line LED circuit to display a word
  - Test the two line LED circuit.

### Requirements

#### Tools/Equipments/Instruments

- Trainees tool kit - 1 Set.
- Digital multimeter with probes - 1 Set.
- Regulator DC Power supply 0-30V/ 2A - 1 No.
- Soldering iron 25W/230V - 1 No.

#### Materials/ Components

- Breadboard/PCB-GP - 1 No.
- Decade counter IC CD4017 - 1 No.
- Timer IC 555 - 1 No.
- Positive regulator IC 7805 - 1 No.
- Diode, IN5402 - 2 Nos.
- Diode, IN4148 - 2 Nos.
- Transistor, SL100 - 2 Nos.
- Transistor, TIP 122 with heat sink - 1 No.

- Capacitor, 10WF, 16V - 1 No.
- Capacitor, 0.1WF - 1 No.
- Capacitor, 0.01WF - 1 No.
- Pre-set, 100KW (Horizontal type) - 1 No.
- Resistor, 10KW, 0.5W - 1 No.
- Resistor, 470W, 0.5W - 3 Nos.
- Resistor, 220W, 0.5W - 5 Nos.
- LED, 5mm, Red - 43 Nos.
- Connecting wires - as reqd.
- Hookup wire - as reqd.
- Rosin cored solder - as reqd.
- Microcontroller board (e.g Arduino Uno)
- Two-line LED display module (e.g 16x2 LCD)
- Breadboard (If necessary)
- Jumper wires

## PROCEDURE

### TASK 1 : Construction of a two line LED circuit to display a word

- 1 Collect all the components required and test them for good working condition.

**Use heat sink for the power transistor T3.**

- 2 Plan the layout and assemble the circuit as shown in Fig 1 on the breadboard/ general purpose PCB.

**The arrangement of LED1 through LED5 is used to display 'I' as shown in Fig.1. The anodes of LED1 through LED5 are connected to point-A and the cathodes of these LEDs are connected to point-B. Similarly, connect the other letters as shown in Fig 1.**

3. Get the assembled circuit checked by the Instructor.

### TASK 2: Testing the two line LED circuit

- 1 Apply 230V, 50Hz, single phase AC supply to the primary of the transformer.
- 2 Switch ON the 9V DC power supply and check the circuit operation.
- 3 Observe the output LED display cycle.

**The display board displays 'ITI,' and 'EM' one after another for one second each. After that, the message "ITIEM" is displayed for 4 seconds (because Q5 and Q6 are connected to resistor R4 via diodes D5 and D6).**

**At the next clock input output Q9 goes high, and IC3 is reset and the display is turned off for one second. Thereafter the cycle repeats.**

- 4 Adjust the pre-set VR of astable multivibrator to change the clock frequency of decade counter to vary the display time.
- 5 Observe the display output for the time/sequence of LED letters.

Fig 1

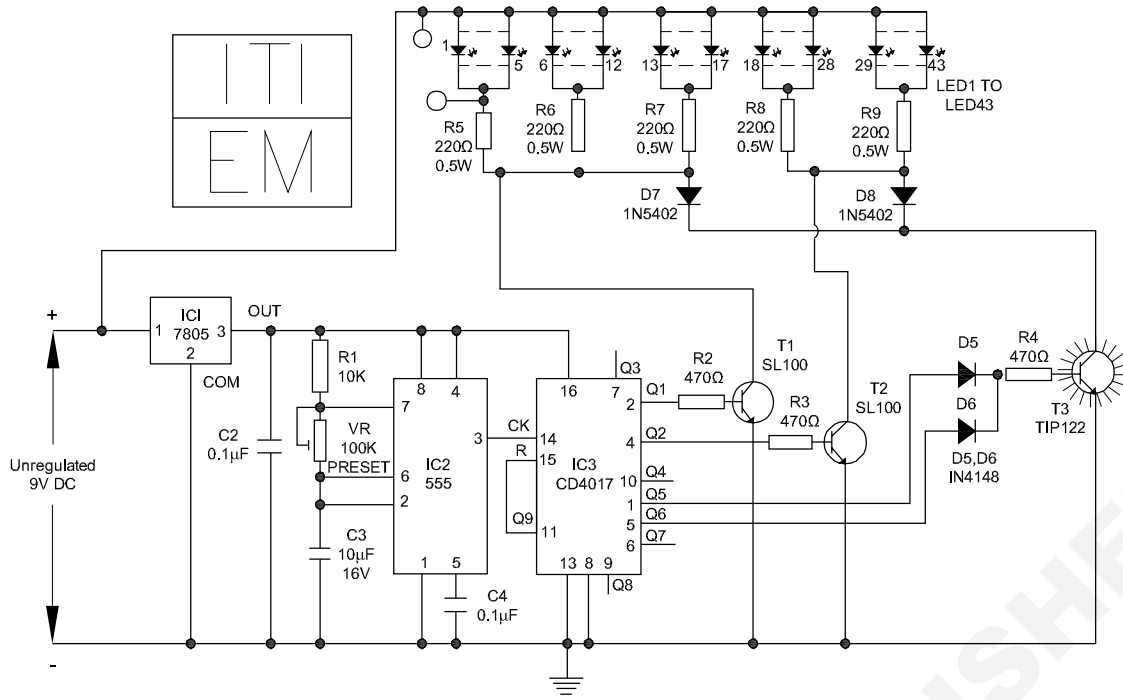

EM20N211206H1

6 Get the work checked by the instructor.

**Measure current flowing through a resistor and display it on LED module**

**Objectives:** At the end of the exercise you shall be able to

- measure the voltage in simple circuit using LED module of DPM
- measure the current in simple circuit using LED module of DPM.

Requirements			
Tools /Equipments/Instruments		Materials/ Components	
• DPM with LED display 0-250 mA	- 1 No.	• Breadboard	- 1 No.
• DPM with LED display 0-50V	- 1 No.	• Resistor 500 W/2W	- 1 No.
• Regulated DC power supply 0-30V/2A	- 1 No.	• Hook up wire	- as reqd.
• Digital multimeter with probes	- 1 No.		
• Trainees tool kit	- 1 Set.		

**Safety precaution**  
**1 Avoid loose connections**

**PROCEDURE**

- 1 Collect the components required and check them for good working condition.
- 2 Make the simple test set-up of the circuit as shown in Fig 1.
- 3 Switch ON the DC power supply, increase to 5VDC.
- 4 Measure the voltage of variable power supply output and current through the load.
- 5 Record the observations in Table-1.
- 6 Increase the supply voltage in steps of 5V upto 25VDC and repeat steps 4 and 5.

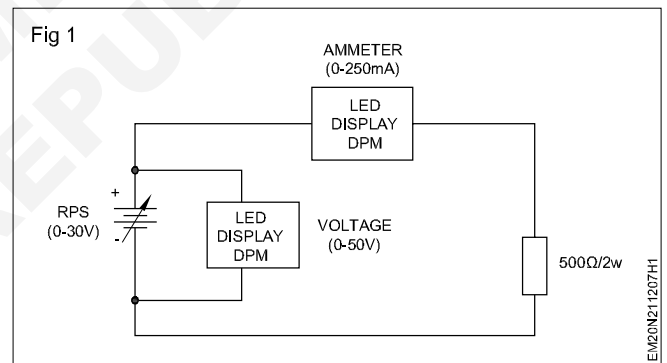

**Table 1**

SI No.	Value of load resistor	Voltage across load Resistor	Current through the load Resistor
1			
2			
3			
4			
5			

- 7 Get the work checked by the Instructor.

-----

Measure current flowing through sensor and display it on LED Module

**Objectives:** At the end of the exercise you shall be able to  
 • measure the current flowing through the digital panel meter.

Requirements	
<b>Tools / Equipments/ Instruments</b>	<b>Materials/ Components</b>
<ul style="list-style-type: none"> <li>• Trainees tool kit - 2 Nos.</li> <li>• Multimeter with probes - 1 No.</li> <li>• Regulator power supply 0-30V/2A - 1 No.</li> <li>• Rectangular battery 9V - 1 No.</li> </ul>	<ul style="list-style-type: none"> <li>• Shunt resistor 0.1 W - 1 No.</li> <li>• Shunt resistor 0.01 W - 1 No.</li> </ul>

**Safety precaution**

- 1 Keep the work area dry and clean.
- 2 Use proper tools for opening the digital panel meter.

PROCEDURE

1 Connect the shunt resistor to digital panel/meter as shown in the Fig.1

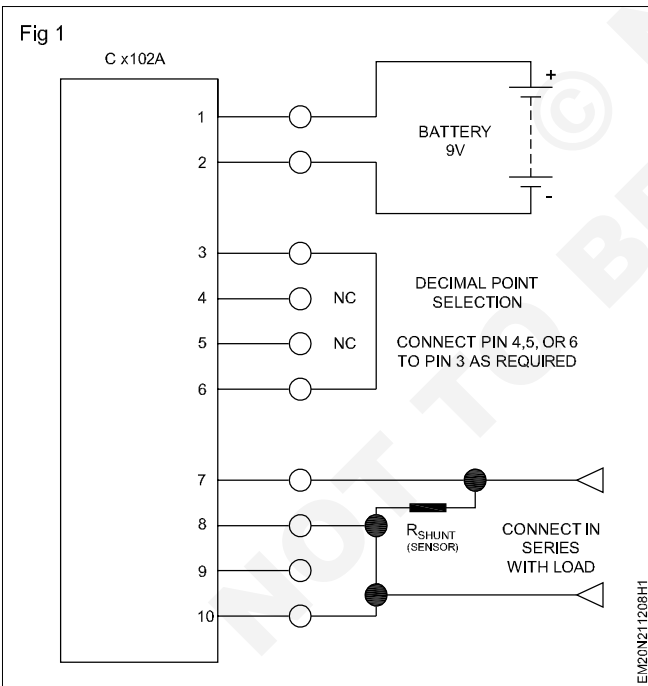

2 The shunt resistor is placed in series with the applied current which causes a voltage drop to occur across the shunt.

3 The shunt value depends on the maximum current flow that will be encountered. For relatively small current values (below 1 Amp) a 0.1 ohm shunt resistor is adequate. This value will minimise any loading in

the circuit but will procedure a reasonable reading on the DPM. If higher current levels will be encountered, 0.01 ohm or lower value should be used.

- 4 Connect the battery to circuit as shown in the diagram.
- 5 Connect the Pin No.3 to Pin No.6 of DPM for proper decimal point display.
- 6 Note that the current value displayed on the meter can be fine-tuned by adjusting the trimmer potentiometer on the back of the DPM.
- 7 Short Pin No.8 and pin No.10 together and connected to the negative end of the shunt resistor.
- 8 Connect  $R_{shunt}$  across Pin No.7 and Pin No.8 and will be connected in series with the load .
- 9 Note down the actual and indicated current readings and record in Table-1.

**Calculation**

- All digital panel meters, the full scale deflection are 200 mV full- scale.
- For the measurement of 1 Amps current through DPM, correct power rating of the shunt resistor can be determined by using the Ohm's Law power formula.

**P (Power) = V (Voltage) x I (Current)**

$P = V_{max} \times I_{max} = (0.200) \times (1.0) = 0.1 \text{ Watt}$

- So we should use a 1/2 watt 1% resistor to be safe.



Table - 1

Value of $R_{Shunt}$	Actual Current Reading	Indicated Reading on DPM	Voltage & cross $R_{shunt}$

-----

© NIMI  
NOT TO BE REPUBLISHED

**Identify LCD display module and its decoder/driver ICs**

- Objectives:** At the end of the exercise you shall be able to
- identify the type of LCD display used in digital panel meter
  - identify the various decoder/driver IC in digital panel meter.

Requirements	
<b>Tools / Equipments/ Instruments</b> <ul style="list-style-type: none"> <li>• Trainees tool kit - 1 Set.</li> <li>• Digital multimeter with probes - 1 No.</li> </ul>	<b>Materials/ Components</b> <ul style="list-style-type: none"> <li>• LCD digital panel meter with different driver ICs - 2 Nos.</li> </ul>

**Safety Precaution**

- 1 Keep use a soft cloth and spread it on a dry and clean area on the workbench Handle the glass panel of the LCD is easily dam on the workbench.
- 2 Use proper tools for opening the digital panel meter.

- 3 If pressure is applied to LCD, orientation may be distructed. The LCD can be broken by shock.
- 4 DC voltage or higher voltage than specified will reduce the life time of the LCD.

**PROCEDURE**

**TASK 1: Identification of the types of LCD display used in digital panel meter**

- 1 Pick any one of the labelled digital panel meter from the instructor as shown in Fig.1
- 2 Note down the name plate details of the digital panel meter in Table -1
- 3 Check the display type (LCD, LED, Dot Matrix, etc.) and note down in Table -1
- 4 Repeat the above steps for all other digital panel meters.

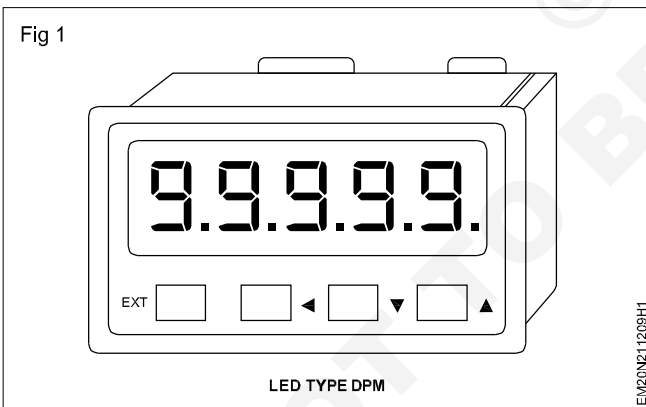

**Table 1**

Label No.	Name plate details of DPM	Display Type	Display colour	Decoder/Driver IC
1				
2				
3				

**TASK 2: Identification of the Decoder/Driver IC in digital panel meter**

- 1 Pick any one of the labelled digital panel meter.
- 2 Remove the back panel in the DPM.
- 3 Remove the circuit board in DPM cabinet.
- 4 Identify the Decoder/Driver IC and record in Table -2
- 5 Repeat the above steps for all other panel meters.

**Table 2**

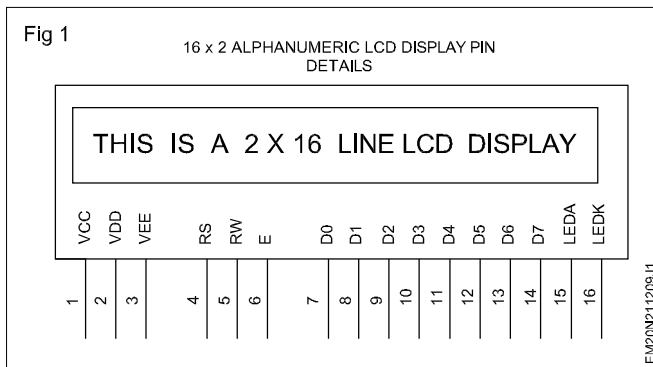

Pin No.	Short form	Description
1	V <sub>SS</sub>	Ground
2	V <sub>DD</sub>	+5V Supply
3	V <sub>EE</sub>	Set LCD Contrast
4	RS	LCD Controlling Pins
5	RW	
6	E	Data Pins
7	D <sub>0</sub>	
8	D <sub>1</sub>	
9	D <sub>2</sub>	
10	D <sub>3</sub>	
11	D <sub>4</sub>	
12	D <sub>5</sub>	
13	D <sub>6</sub>	Back light LED anode +5V
14	D <sub>7</sub>	
15	LEDA	Back light LED cathode ground
16	LEDK	

Terminal details of LCD DPM

**Measure current flowing through a resistor and display it on LCD module**

- Objectives:** At the end of the exercise you shall be able to
- measure the voltage in single circuit using LCD module
  - measure the current in simple circuit using LCD module.

Requirements			
Tools / Equipments/ Instruments		Materials/ Components	
• DPM with display	- 2 Nos.	• Breadboard	- 1 No.
• Regulated DC power supply 0-30V/2A	- 1 No.	• Resistor 500W/2W	- 1 No.
• Digital multimeter with probes	- 1 No.	• Hookup wires	- as reqd.
• Trainees tool kit	- 1 Set.		

**Safety precaution**

**1 Avoid loose connections**

**PROCEDURE**

- 1 Collect the components and check the items for its good working condition.
- 2 Make the simple test set-up on the Lug board/Bread board as shown in Fig.1
- 3 Switch ON the variable power supply.
- 4 Measure the voltage varying the voltage step by step and current
- 5 Record it on the table-1.
- 6 Repeat steps 5 & 6 with five different position of rheostat.
- 7 Switch OFF the Regulated DC Power supply and get the work checked by the instructor.

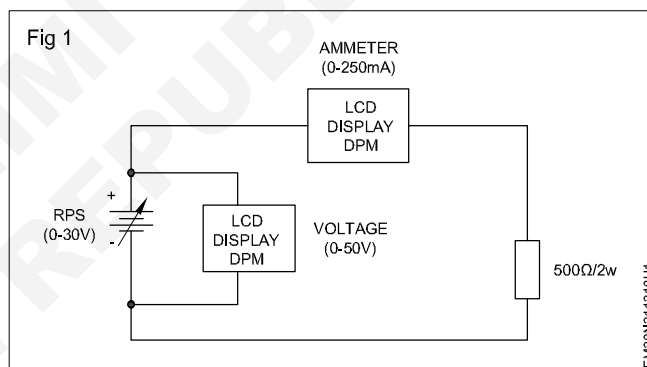

**Table 1**

SI. No.	Value of Load Resistor	Voltage across Load Resistor	Current through the circuit Resistor
1			
2			
3			
4			
5			

## Identify the components/devices of SMPS and draw their corresponding symbols

**Objectives:** At the end of the exercise you shall be able to

- dismantle the SMPS unit from CPU cabinet and identify major section/ components of SMPS unit
- draw the symbols of observed components of SMPS unit.

### Requirements

#### Tools / Equipments/ Instruments

- ESD wrist band - 1 No.
- Trainees tool kit - 1 Set.
- Digital multimeter with probes - 1 No.
- Aids: Block diagram of SMPS - 1 No.

- Chart showing all types of connectors used in SMPS of PC - 1 No.

#### Materials/ Components

- SMPS unit used in personal computer - 1 No.

### Safety precaution

- 1 Ensure the power cord is removed from the CPU.
- 2 Before opening CPU cabinet, touch the cabinet outer cover by wearing wrist band to discharge ESP.

## PROCEDURE

### TASK 1: Dismantling the SMPS unit from CPU cabinet and identification of sections

- 1 Open the computer cabinet cover, by removing the door screws as shown in Fig 1.

Fig 1

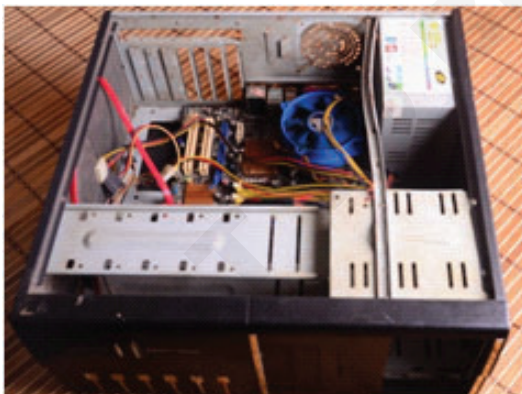

- 2 Identify the location of wires with colour codes coming out of SMPS unit as shown in Fig 2.
- 3 Note down the connections of SMPS going to various sections of mother board and other devices inside the CPU, put tags with label for each connector.
- 4 Draw the layout of mother board and mark the sections/ location of connectors with label number in it.

Fig 2



- 5 Record the name of the connector, type and number of pins in Table-1.
- 6 Remove/Unplug the connectors from HDD, DVD, FAN and mother board carefully.
- 7 Unscrew the fixing screws and remove the SMPS unit from the CPU cabinet and open it as shown in Fig 3.
- 8 Draw the layout of the assembly and mark the major sections/components/devices

Keep the fixing screws separately for assembling the SMPS after completion of this exercise.

Fig 3

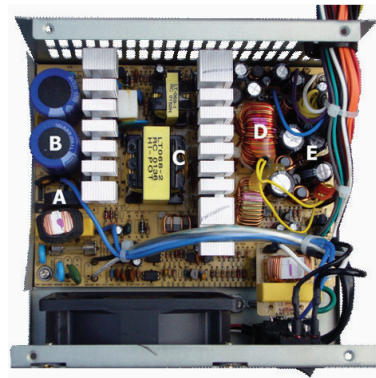

Table - 1

SI.No.	Name of the connector	No. of wires	Type of connector	Connected to which section/device	Remark

9 Get the work checked by the instructor.

**TASK 2: Identification of type of connectors in SMPS unit**

**Note : The instructor has to label the major components /devices in each section of the SMPS before issuing to trainees for this task**

- 1 Refer to the chart, identify the connector/sections and major components/devices in each section.
- 2 Record the name of the component/device in Table - 2.

- 3 Repeat the steps for all the labelled components/ devices.
- 4 Draw the symbol of each component in the respective places in Table-2.

Table- 2

SI. No.	Label No.	Name of the section	Name of the component	Circuit symbol	Remark

### Chart - 1

Chart showing types of connectors used in SMPS unit of personal computer system

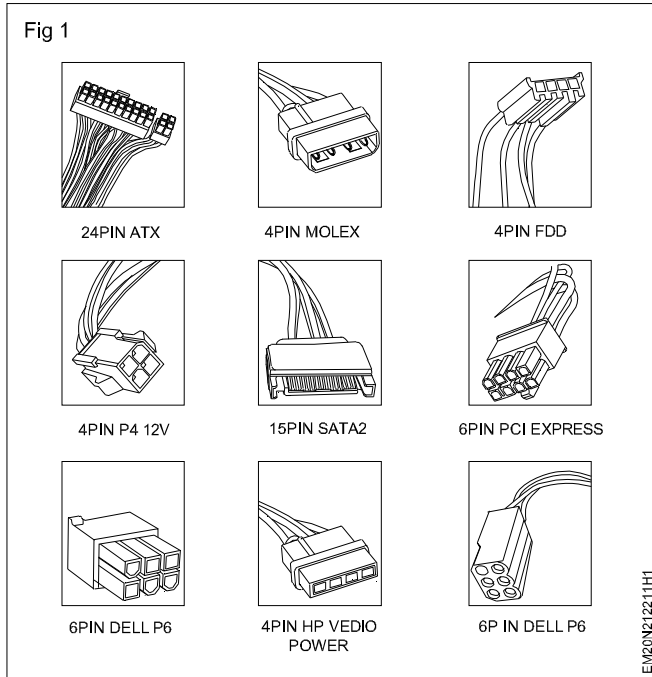

5 Get the work checked by the instructor.

**Dismantle the given voltage stabilizer and find the major sections/ICs/ Components**

**Objectives:** At the end of the exercise you shall be able to

- **dismantle the given voltage stabilizer**
- **identify sections of voltage stabilizer**
- **locate the major components of various sections.**

Requirements	
Tools/ Equipments/ Instruments	Materials/ Components
<ul style="list-style-type: none"> <li>• Trainees tool kit - 1 Set.</li> <li>• DMM with probes - 1 Set.</li> <li>• Voltage stabilizer (automatic type with instruction manual) 500VA to 1KVA - 1 No.</li> </ul>	<ul style="list-style-type: none"> <li>• Nil</li> </ul>

**Note: The instructor may guide the trainees to handle the bulky/weight of the voltage stabilizer. Alert them to avoid any accidental wound by the sharp edge/corner of the metal chassis/frame etc. Remove the power cord from the A/C mains supply.**

**PROCEDURE**

- |   |   |
|---|---|
| <ol style="list-style-type: none"> <li>1 Note down the name plate details of the voltage stabilizer and record them in Table-1</li> <li>2 Identify the fitting screws/fasteners used on the sides of the chassis /frame of the voltage stabilizer.</li> <li>3 Remove the cover fitting screws/nut bolt etc. and keep them safely in a box separately</li> <li>4 Observe various sections of the stabilizer unit &amp; identify the sections. Trace the layout of components and identify and important components.</li> </ol> | <ol style="list-style-type: none"> <li>5 Use pencil roughly sketch the layout of the assembly and the voltage stabilizer on your observation record.</li> <li>6 Note down the connections of major/important components/parts on each section.</li> <li>7 Record the observations on the Table-1.</li> <li>8 Get the work checked by the Instructor.</li> </ol> |
|---|---|

**Table-1**

SI.No.	Major/important component/parts	Name of section	Remarks
1	Auto transformer		
2	Relay switching contacts		
3	Driver transistors		
4	Integrated circuits voltage adj		
5	Presets diodes/zener status indicators		
6	Fuse		
7	Output terminal socket		



**List the defect and symptom in the faulty SMPS**

**Objectives:** At the end of the exercise you shall be able to

- list the physical defects identified in the faulty SMPS (in cold condition) without switching ON
- identify the probable symptoms of the given faulty SMPS.

<b>Requirements</b>			
<b>Tools / Equipments/ Instruments</b>		<b>Materials/ Components</b>	
• Trainees tool kit	- 1 Set.	• Spare components	- as reqd.
• Multimeter with probes	- 1 No.	• Rosin cored solder	- as reqd.
• Adjustable type table lamp	- 1 No.		
• Magnifying Lens	- 1 No.		
• A faulty SMPS kit	- 1 No.		
• Oscilloscope, 20 MHZ	- 1 No.		

**Safety precautions**

- 1 Disconnect the SMPS unit from the mains before removing from the PC.**
- 2 Do not touch the PCB with bare hand without discharging the DC storage electrolytic capacitor.**
- 3 Discharge the storage capacitor by using an incandescent-bulb connected with wires across the capacitor.**

- 4 Do not use screw drivers to short the capacitor terminals for discharging static charge.**
- 5 Measure the voltage and make sure it is zero before proceeding for test.**

**PROCEDURE**

**TASK 1: List the defect in the faulty SMPS in cold condition**

- |   |   |
|---|---|
| <ol style="list-style-type: none"> <li>1 Record the specifications on the cover of SMPS.</li> <li>2 Verify whether mains supply voltage is disconnected from the SMPS.</li> <li>3 Initially perform cold check by keeping SMPS in OFF condition (components on PCB of the defective)</li> </ol> <p>Observe the SMPS and list out the physical defects noticed as shown below:</p> <ul style="list-style-type: none"> <li>• Charred/smoke smell on PCB</li> <li>• Any component like resistor, diode, black (or) charred/ damage.</li> <li>• Capacitor top bulged (or) not.</li> <li>• PCB board darkened due to short</li> <li>• Wire broken</li> </ul> | <ul style="list-style-type: none"> <li>• PCB track cut</li> <li>• Connector broken</li> <li>• Dry soldering</li> <li>• Switching transistor blown</li> <li>• Fuse blown.</li> </ul> <ol style="list-style-type: none"> <li>4 Perform warm check of SMPS and measure output voltages                     <ul style="list-style-type: none"> <li>• Observe whether the SMPS fan is working or not.</li> <li>• Observe the voltages at the connectors and various test points and record the observations in Table 1 &amp; Table 2.</li> </ul> </li> </ol> |
|---|---|



## TASK 2: Find the probable symptoms of the given faulty SMPS

- 1 Observe the symptoms noticed on the defective SMPS in ON condition and determine which section or junction could be faulty.
- 2 Ref to the list of symptoms and remedy given in Table-1 and prepare a list symptoms noticed in your faulty SMPS units.

### Probable faults and remedy

Sl. No.	Faults	Cause	Remedy
1	SMPS dead, fuse blown	Shorted switching transistor or semiconductors, power cord defective, or switch, open fusible resistor, other bad parts. Actual cause of failure may be power surge/brownout/lightning strikes, random failure, or primary side electrolytic capacitor (s) with greatly reduced capacity or entirely open	Test the switching transistor or semiconductor switch. If it fails replace it. If the semiconductor switch is good, check and replace the primary diodes. Replace the fusible resistor.
2	Supply dead, fuse not blown	Bad startup circuit - open startup resistors or open fusible resistors due to shorted semiconductors, bad controller components.	Test the switching transistor or semiconductor switch. If it fails replace it. Replace the fusible resistor
3	Supply mostly dead or takes a long time to come alive	Bad electrolytic capacitors. Visually inspect for capacitors with bulging tops or that have leaked.	If any one bad capacitors are found replace all electrolytic capacitors.
4	More ripple at the line frequency (50/60 Hz) or twice the line frequency (100/120 Hz)	Dried up main filter capacitor(s) on rectified AC input	Check the filter capacitor and replace it
5	No output supply and 300V persists in the filter capacitor after switching OFF the supply	Switching transistor or semiconductor switch short and fusible resistor or starting resistor open.	Test the switching transistor or semiconductor switch. If it fails replace it.
6	SMPS output is low	If SMPS gives low voltage output then the fault is mostly in the error amplifier, and oscillator stage. Output loading may also affect the output voltage some time	Measure voltages and compare them with normal voltage given the circuit diagram. Probable parts may be faulty zener diode in the error amp, faulty control circuit parts, transistor, IC, opto-coupler faulty.
7	SMPS output is high	If SMPS output is high first shut down set. Fault in the error amplifier, IC, oscillator section of SMPS.	Check fault either in switch off condition or by giving input supply through a variac or low voltage transformer.

Sl. No.	Faults	Cause	Remedy
			<p>Disconnect TV/computer other sections by disconnecting base or output transistor. Never keep on in this fault it may damage other parts also.</p> <p>Check for - error amp circuit, zener diode, opto-coupler, filters on error amplifier line, transistor, IC, oscillator. Replace the faulty components.</p>
8	Combusted coil	A winding coil is present on the board which sometimes gets burnt due to excessive flow of current.	This problem can be identified easily by the smell or you can identify through the burnt marks located on the external section of the winding coil. It may be possible that internal loop is damaged.

**Note:** In all cases, bad solder connections are a possibility as well since there are usually large components in these supplies and soldering to their pins may not always be perfect. An excessive load can also result in most of these symptoms or may be the original cause of the failure.

3 Get the work checked by the instructor.

## Measure/ Monitor at major test points of computer SMPS unit

**Objectives:** At the end of the exercise you shall be able to

- prepare the computer SMPS unit for voltage measurements
- measure/monitor voltages at various test points of the SMPS unit.

### Requirements

#### Tools / Equipments/ Instruments

- Computer SMPS working - 1 No.
- Trainees tool kit - 1 Set.
- Digital multimeter with probes - 1 No.

#### Materials/ Components

- AIDS: Chart showing various voltages of connects in smps unit of PC
- Computer power cord - 1 No.
- Hook-up wire - as reqd.

### Safety precautions

Make sure you conduct this test on a table with yourself standing a rubber that any insulated material to avoid static electricity destroying the computer components.

## PROCEDURE

### TASK 1: Preparation of computer SMPS unit for voltage measurements

- 1 Remove the SMPS from the computer cabinet by follow the procedure given in the Exercise: 4.3.256
- 2 Identify the green colour wire (power good signal test point) from the bunch of wires on the 24 pin molex connector as shown in Fig 1.

Fig 1

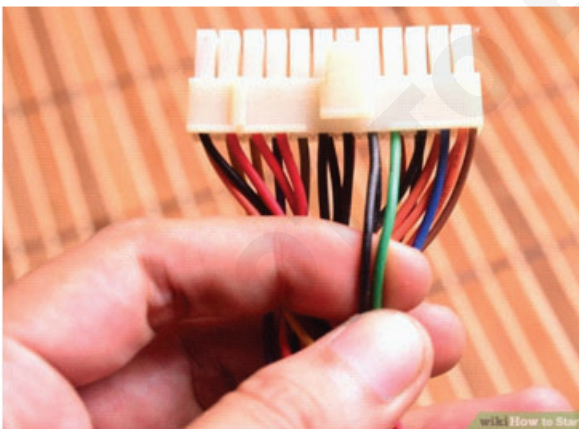

- 3 Use a piece of hookup wire, bend it as 'U' shape, connect it across the green and black wire terminals as shown in Fig 2.

Fig 2

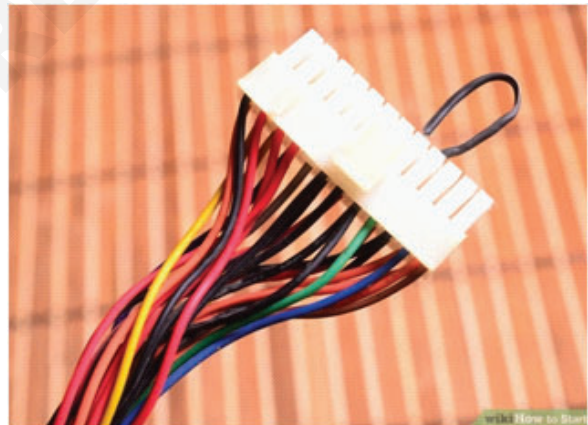

- 4 Connect the power cord to the SMPS unit and switch ON power.
- 5 Observe the fan is running to confirm the working of SMPS unit.
- 6 Remove the hook up wire and re-insert if the fan is not rotating.
- 7 Get the work checked by the instructor.

**TASK 2: Measurement/monitoring voltages at various test points.**

- 1 Start measurement of AC voltage across the three terminal mains cord and record the readings in Table-1.

**Table 1**

SI. No.	Parameter to measure	Voltage (AC)	Remarks
1	Phase to Neutral	-----	
2	Phase to Earth	-----	
3	Neutral to Earth	-----	

- 2 Switch OFF supply and plug the mains cord into SMPS unit, and select the P-4 power cable connector used for CPU cooler fan.
- 3 Switch ON SMPS supply and measure the DC voltage across the P-4 cable connector and record the readings in Table-2.

**Table 2**

SI. No.	Description	Wire colour	Measured voltage
1	Ground	Black	
2	Ground	Black	
3	+12 VDC	Yellow	
4	+12 VDC	Yellow	

- 4 Refer to the chart showing voltages at various test points on power cable connector and record the observations in Table-3.

**Table 3**

SI. No.	Wire colour	Description	Measured voltage	Remarks
1				
2				
3				
4				
5				
6				
7				
8				
9				
10				

- 5 Refer to the chart details and measure test point voltage at the 4 pin molex peripheral connector and record observation in Table-4.

-----

**Table 4**

SI. No.	Wire colour	Description	Measured voltage	Remarks
1	Yellow			
2	Black			
3	Black			
4	Red			

6 Get the work checked by the instructor.

**Note: The instructor has to guide the trainees to measure voltage at additional connectors for SATA, Aux power connector etc. with preparation of suitable tables to record measurements according to the SMPS model available in the section.**

**Chart showing voltages at various connectors of SMPS units of personal computer system**

**PIN DESCRIPTION OF THE 24-PIN POWER CABLE CONNECTOR**

Pin	Name	Colour	Description/voltage level	Measured voltage
1	3.3V	Orange	+3.3 VDC	
2	3.3V	Orange	+3.3 VDC	
3	COM	Black	Ground	
4	5V	Red	+5 VDC	
5	COM	Black	Ground	
6	5V	Red	+5 VDC	
7	COM	Black	Ground	
8	PWR_OK	Grey	Power Ok is a status signal generated by the power supply ON, disconnect from GND to switch OFF.	
9	5VSB	Purple	+5 VDC Standby voltage (max 10mA)	
10	12V	Yellow	+12 VDC	
11	12V	Yellow	+12 VDC	
12	3.3V	Orange	+3.3 VDC	
13	3.3V	Orange	+3.3 VDC	
14	-12V	Blue	-12 VDC	
15	COM	Black	Ground	
16	PS_ON	Green	Power supply on (active low), short this pin to GND to switch power supply ON, disconnect from GND to switch OFF.	

17	COM		Black	Ground	
18	COM		Black	Ground	
19	COM		Black	Ground	
20	-5 V		White	Ground	
21	+5V		Red	+5 VDC	
22	+5V		Red	+5 VDC	
23	+5V		Red	+5 VDC	
24	COM		Black	Ground	

**PIN description of the P-4 power cable connector**

Pin	Name		Colour	Description/Voltage Level	Measured Voltage	
1	GND		Black	Ground		
2	GND		Black	Ground		
3	12V DC		Yellow	+12 VDC		
4	12V DC		Yellow	+12 VDC		

**PIN description of the 4-PIN molex peripheral connector**

Pin	Name		Colour	Description/Voltage Level	Measured Voltage	
1	12V DC		Yellow	+12 VDC		
2	GND		Black	Ground		
3	GND		Black	Ground		
4	+5V		Red	+5 VDC		

**Ac input voltage measurement (at the mains socket)**

**Table - 5**

SI. No	Parameters to measure	Voltage (AC)	Remarks
1	Phase to neutral voltage		
2	Phase to earth		
3	Neutral to earth		

Pin Number	Pin Name	Description
1	+5V	
2	GND	
3	+5V	
4	GND	
5	PG	+5V When power good
6	+5V STB	Stand-by power
7	+12V	
8	-12V	
9	GND	
10	GND	
11	PWR_ON	Connect to ground to power on
12	GND	
13	GND	
14	GND	
15	-5V	
16	+5V	
17	+5V	
18	+5V	
19	TFSC	Thermal Fan speed control.
20	+5V	

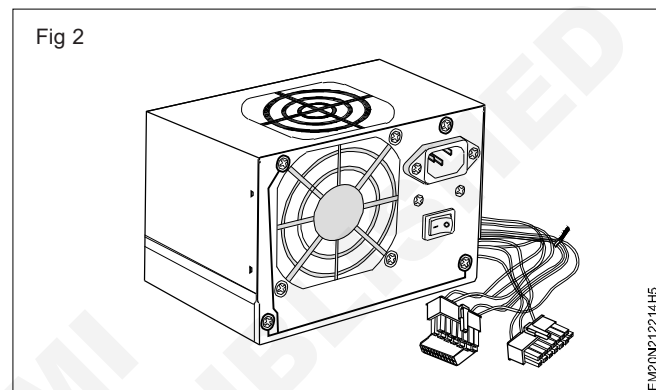
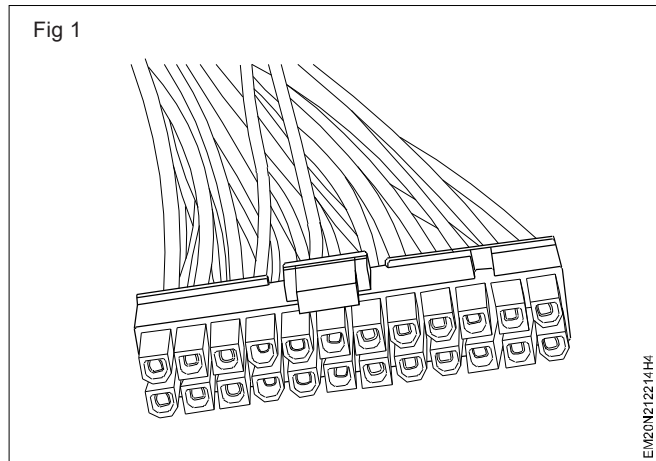

Another type of 20 Pin power connector used in new PCs.

Cable colors may differ between power supplies.

TFSC mainboard puts 0.7-1.4V there to control voltage supplied to power supply's fan

(Fan voltage increases when TFSC increases).



Troubleshoot the fault in the given SMPS unit, rectify the defect and verify the output with load (Record your procedure followed for troubleshooting the defects)

Objectives : At the end of this exercise you shall be able to

- discharge the filter capacitor of SMPS unit
- identify the physical faulty component and replace it and test the output with load
- identify the short circuit fault using bulb
- identify the short circuited components
- to connect SMPS performing load test.

### Requirements

#### Tools/Equipments/Instruments

- ESD work bench - 1 No.
- Safety gloves - 1 No.
- Trainees tool kit - 1 Set.
- Digital multimeter with probes - 1 Set.
- LCR Meter - 1 No.

#### Materials/ Components

- 100 watt/230V bulb with holder - 1 No.
- Wire wound resistor (1.8kΩ or 2.2kΩ/10W) - 1 No.

#### Safety precaution

- 1 Keep the place dry and clean
- 2 Make sure you conduct this test on a table with yourself standing on a rubber mat or any insulated material to avoid static electricity destroying the computer peripherals.

- 3 Please note that some connections of the SMPS connectors contain a clip attached to it. Make sure to remove the clips before removing the connection.

### PROCEDURE

#### TASK 1 : Discharging the filter capacitor

##### A Discharge using bulb method

**Make sure the power cord is removed from the SMPS to avoid Electrical shock.**

- 1 Dismantle the SMPS by referring to the procedure given in the previous exercises.

Fig 1

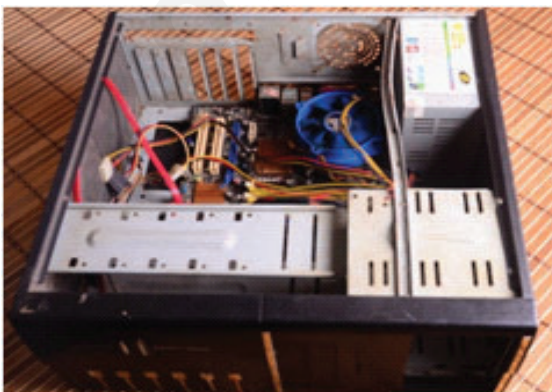

- 2 Connect 100 watt bulb wire across the leads of the capacitor as shown in Fig 1 & 2. Filter capacitors will be discharged.

Fig 2

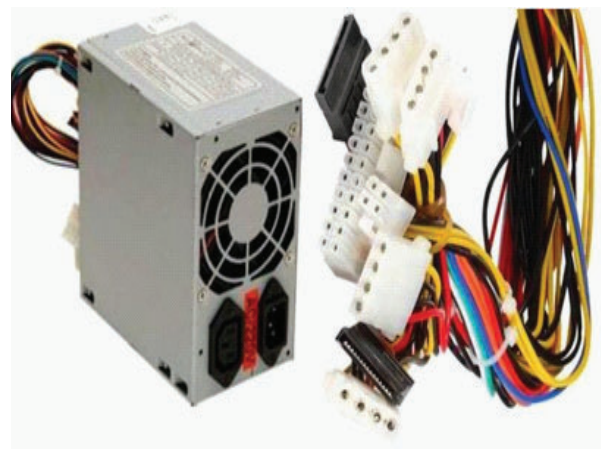

## B Discharge using resistor Method

- 1 Take a High wattage Low ohms wire wound resistor with proper insulated lead.
- 2 Use the resistor lead to short the capacitor to discharge as shown in Fig 3.
- 3 Use either a 1.8 K or a 2.2 K ohm 5 to 10 watt resistor to discharge the high voltage capacitor.
- 4 Get the work checked by the instructor.

Fig 3

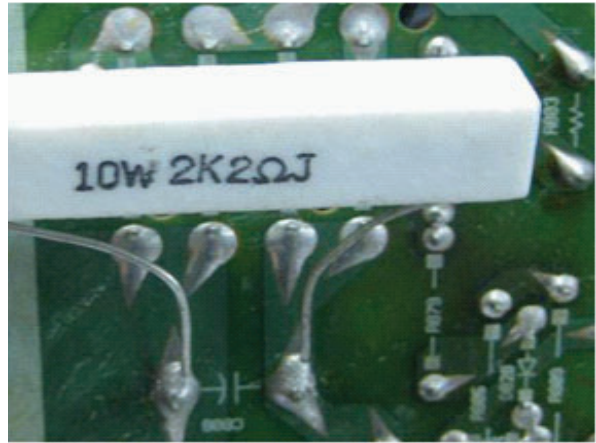

## TASK 2 : Identification of the physical fault (fuse blown) in SMPS

- 1 Take the dismantled SMPS as shown in Fig 1.

Fig 1



- 2 The board from the SMPS cabinet is similar to as shown in Fig 2.

Fig 2

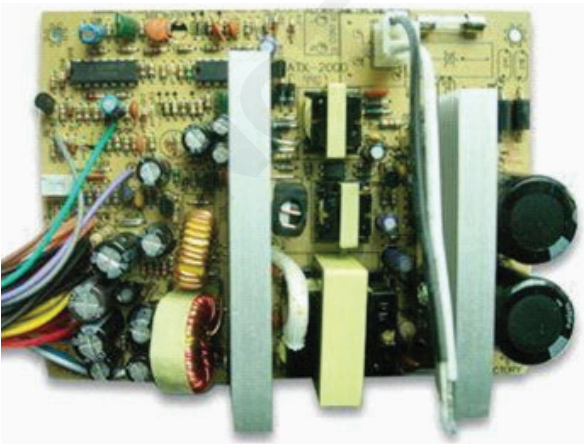

- 3 Disconnect the SMPS and make sure all electrolytic capacitors are discharged.

- 4 Remove the fuse from its holder as shown in Fig 3.

Fig 3

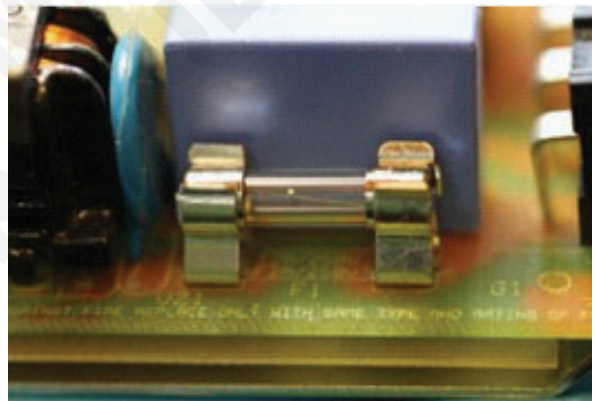

- 5 Look the fuse wire if there is a visible gap in the wire as shown in Fig 4.

Fig 4



- 6 Look the fuse carefully any dark or metallic smear inside the glass as shown in Fig 5.

- 7 If any above faults found in the fuse then the fuse is blown and needs to be replaced.

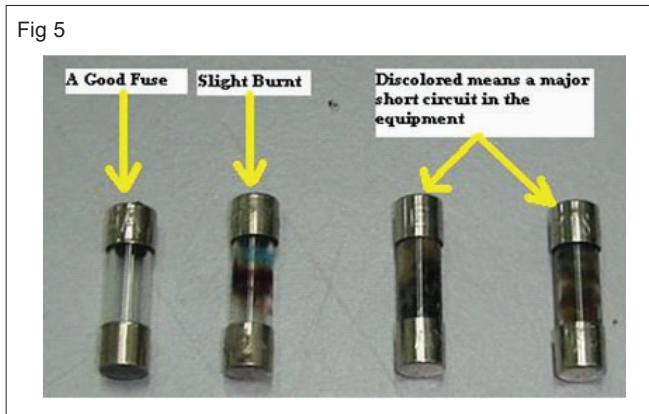

- 8 If there is no physical fault observed in fuse then use multimeter to check it.
- 9 Set a multimeter (Fig 6) to the continuity setting.
- 10 Place one of the multimeter leads on one end of the fuse. Place the other lead on the other end of the fuse as shown in the Fig 6.
- 11 If the meter shows continuity, as shown in Fig 6(a) then the fuse is good.
- 12 If the multimeter reading is OL(Over Limit) as shown in Fig 6(b), then the fuse is blown. If the fuse is blown, replace the fuse with one that is exactly having the same current rating.
- 13 Record the observations in TABLE 1.
- 14 Get the work checked by the instructor.

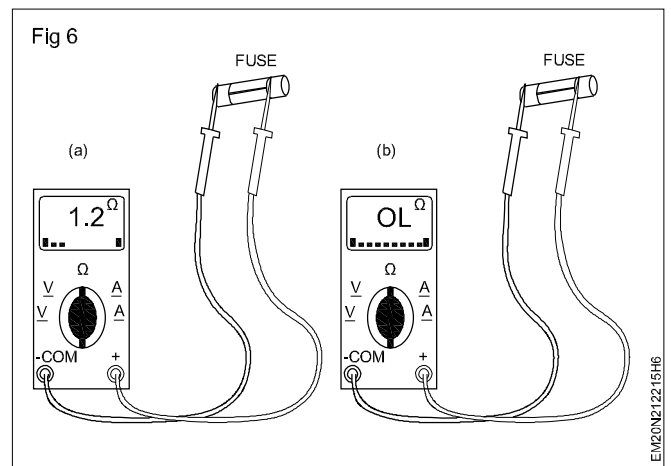
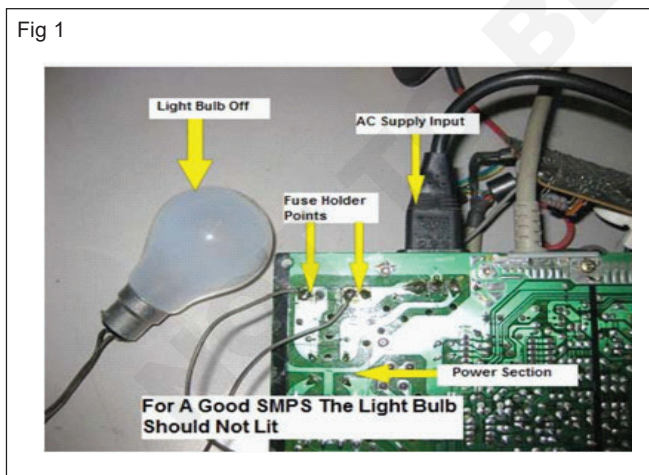

Table 1

Observed	Condition

### TASK 3 : Identification of the short circuit fault using bulb

- 1 Connect the 100W bulb across the fuse holder as shown in Fig 1.



- 2 Power ON the SMPS unit.
- 3 The bulb will be initially glowing bright then for a good SMPS bulb glowing turns off, SMPS is in good / working condition.
- 4 The light bulb will glow bright even after you have waited for couple of minutes as shown in Fig 2, then it indicates there is problem in the SMPS.

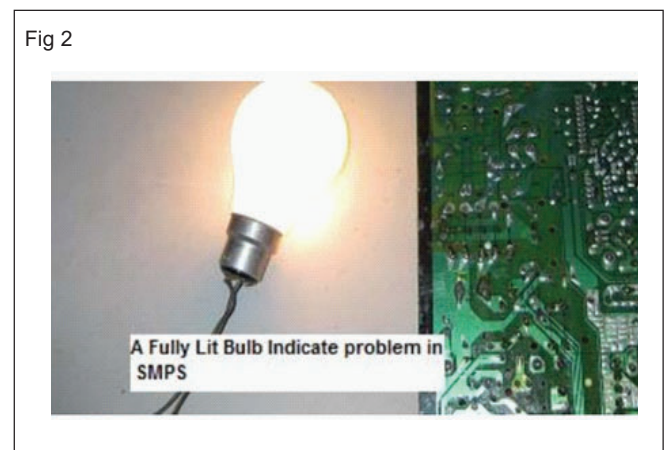

- a) Immediately switch off the AC main.
- b) Discharge the big filter capacitor as given in TASK 1.
- 5 Record the observation in the TABLE 2.
- 6 Get the work checked by the instructor.

Table 2

Observed bulb status	SMPS status

**B Identification the fault in short circuited components using Resistance method**

- 1 Set the DMM to resistance unit.
- 2 Keep the red probe to the cold ground and black probe to each of the secondary diode as shown in Fig 3.

Fig 3

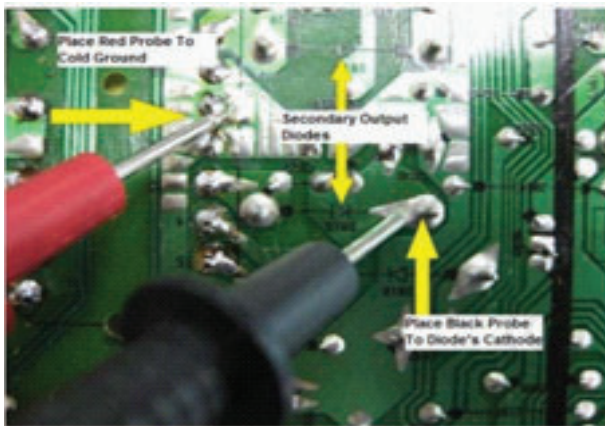

Fig 4



- i) If any one of the component shows same resistance reading (low readout) on both polarity, then suspect that there is a problem in that component.
  - ii) If the multimeter shows different values on both polarities then the component is good.
- 3 Get the work checked by the instructor.

**C Isolation method**

- 1 Identify the B+ line of the Back/Boost sections and break/disconnect the B+ line from the circuit as shown in Fig.5

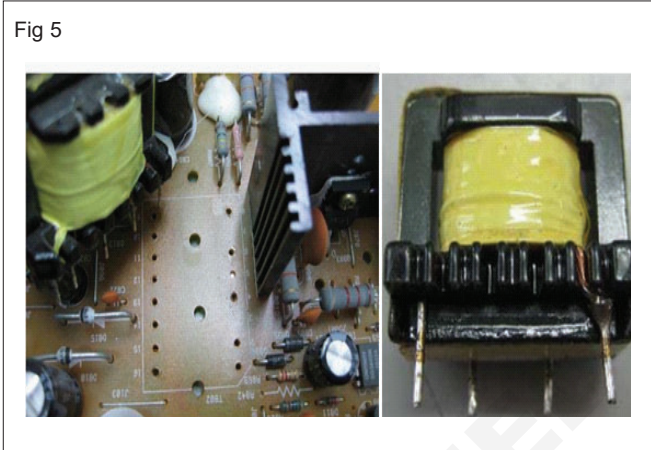

- 2 Connect the 100 W bulb between the B+ line to cold ground.
- 3 Power ON and verify the bulb glowing condition.
- 4 There are five possibilities that can be expected from the light bulb.
  - a) The light bulb lit with a constant brightness and all of the output voltage measured normal at the secondary side this indicates the SMPS is working fine and the cause of the power problem in the load side. It maybe fly back transformer, yoke coils etc.
  - b) No light from the light bulb and no voltage measured at the output of the power supply, this indicates the problem is in the SMPS.
  - c) The light bulb glows intermittently this could indicate components failure in the power supply like bad filter capacitor, current sense resistor higher ohm, etc. (value would have been increased)
  - d) The light bulb become extra bright and all the output voltages have increased. this indicates the problem is in the regulation circuit like an open resistor in feedback circuit, bad opto isolator IC faulty TLC431 IC, etc.
  - e) The light bulb keeps cycling (continuously ON and OFF). This could indicate problem in the SMPS area and it can also mean the OPTO IC is sending an Error signal to the primary circuit of power supply through opto isolator IC causing the power supply to cycle.
- 5 Record the observation in the TABLE 3.

**Table 3**

Sl. No.	Probable defect	Tick

Fig 6

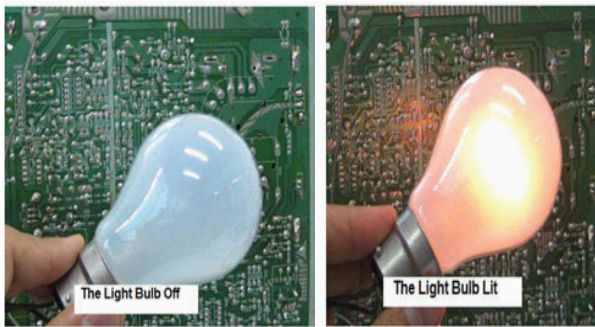
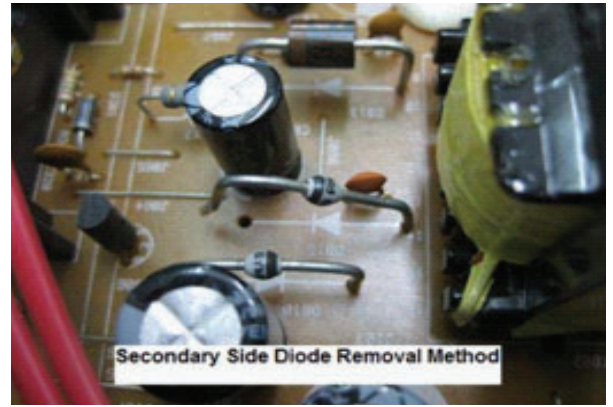

Fig 7



6 Get the work checked by the instructor.

**TASK 4 : Identification of the short circuited components**

**Capacitor checking**

- 1 Disconnect the power card.
- 2 Discharge the main(large) capacitor.

Fig 1



- 3 Test the healthiness of diodes and capacitors at secondary section using multimeter.
- 4 Open the lead of capacitor and measure capacitance using LCR meter.
- 5 Apply the supply to board and check the output voltage with out capacitor.
- 6 If the output voltage is less (or) no output measured, then fault may be in capacitor.

7 Switch OFF the supply and replace the capacitor.

Fig 2

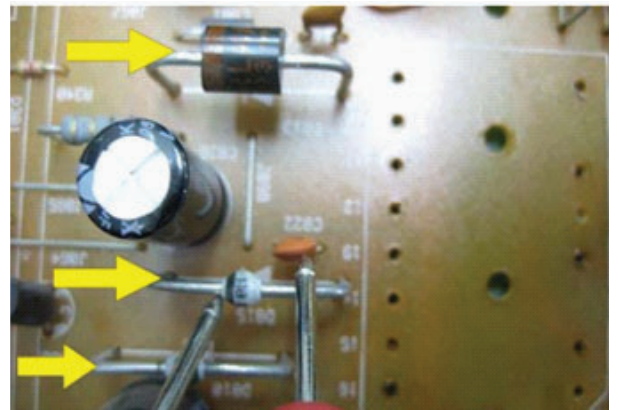

- 8 Switch ON the supply and check the output voltage.
- 9 Record the observation in TABLE 4.

**Table 4**

Measured output voltage	
Without capacitor	With capacitor

Fig 3

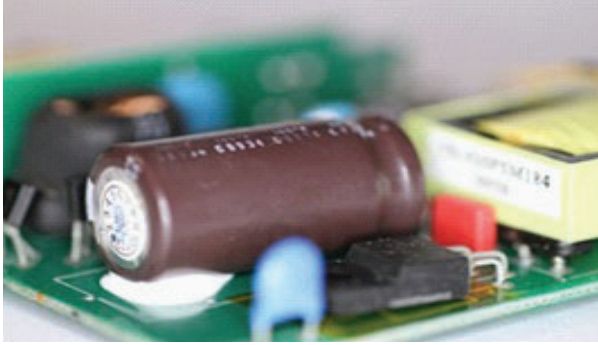

**Note: To confirm fault with switching transistor check the charge voltage across big filter capacitor in the input section. (after switching OFF the SMPS).**

- a) If the capacitor shows voltage considerably then the fault could be in the switching transistor.
- b) If the capacitor shows No voltage then the fault could be in some other components/ section.

10 Get the work checked by the instructor.

**TASK 5 : Connection of SMPS the circuit for performing load test**

1 Connect the circuit as shown in Fig 1 across 5V terminals.

5 Observe that even when the current is varied by the load, the output of SMPS remains constant at the rated voltage.

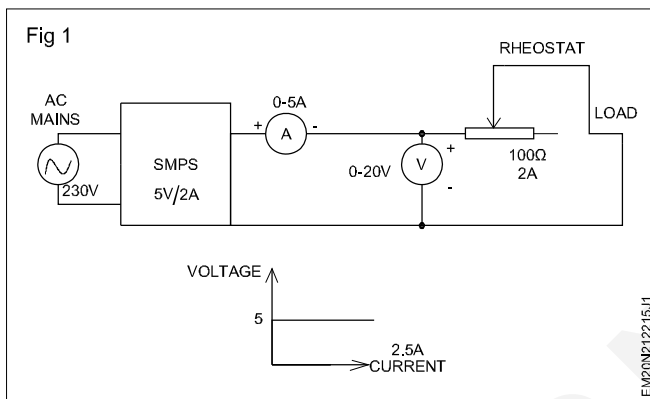

**Table 5**

SI.No.	Load current(mA)	Voltage(V)

6 Get the work checked by the instructor.

2 Keep the rheostat in max resistance position.

3 Power ON the circuit.

4 Increase the current in steps of 200mA, note down the corresponding voltage and tabulate the reading in the Table 5.

**Use SMPS used in TVs and PCs for practice**

**Objectives :** At the end of this exercise you shall be able to  
 • trace and test the different types of SMPS.

Requirements			
Tools / Equipments/ Instruments		Materials/ Components	
• Trainees tool kit	- 1 Set.	• Different type of SMPS (TV SMPS, PC SMPS, Laptop SMPS, Mobile charge (SMPS) etc)	- as reqd.
• Digital Multimeter with probe	- 1 No.	• Sketch per	- as reqd.

**PROCEDURE**

- 1 Pick any one of the SMPS from assorted SMPS units and label it,
- 2 Unscrew the case/cover of the SMPS unit.
- 3 Note down the specification of SMPS and record
- 4 Identify the sections of SMPS units and its corresponding major components/devices.
- 5 Trace the circuit and identify the type of SMPS unit by referring the components/devices available in the unit.
- 6 Mark the test points on the PCB using sketch pen.
- 7 Power ON the SMPS unit.
- 8 Measure and record the voltage at various test points/ connectors as shown in table - 1.
- 9 Repeat the above steps for all other SMPS units.
- 10 Different types of SMPS shown in below (Fig 1 - Fig 9)

**Table-1**

SI.No	Description	Voltage
1	Ac input voltage	
2	AC input voltage after fuse	
3	Rectified output voltage of input section.	
4	Switching transistor ( $V_{CE}$ )/ MOSFET voltages(VDs)	
5	Rectified DC output of output section	

**Note: For measurement of primary voltages use primary ground (Hot side-input section) and use secondary ground (cold side - output section) for secondary voltage.**

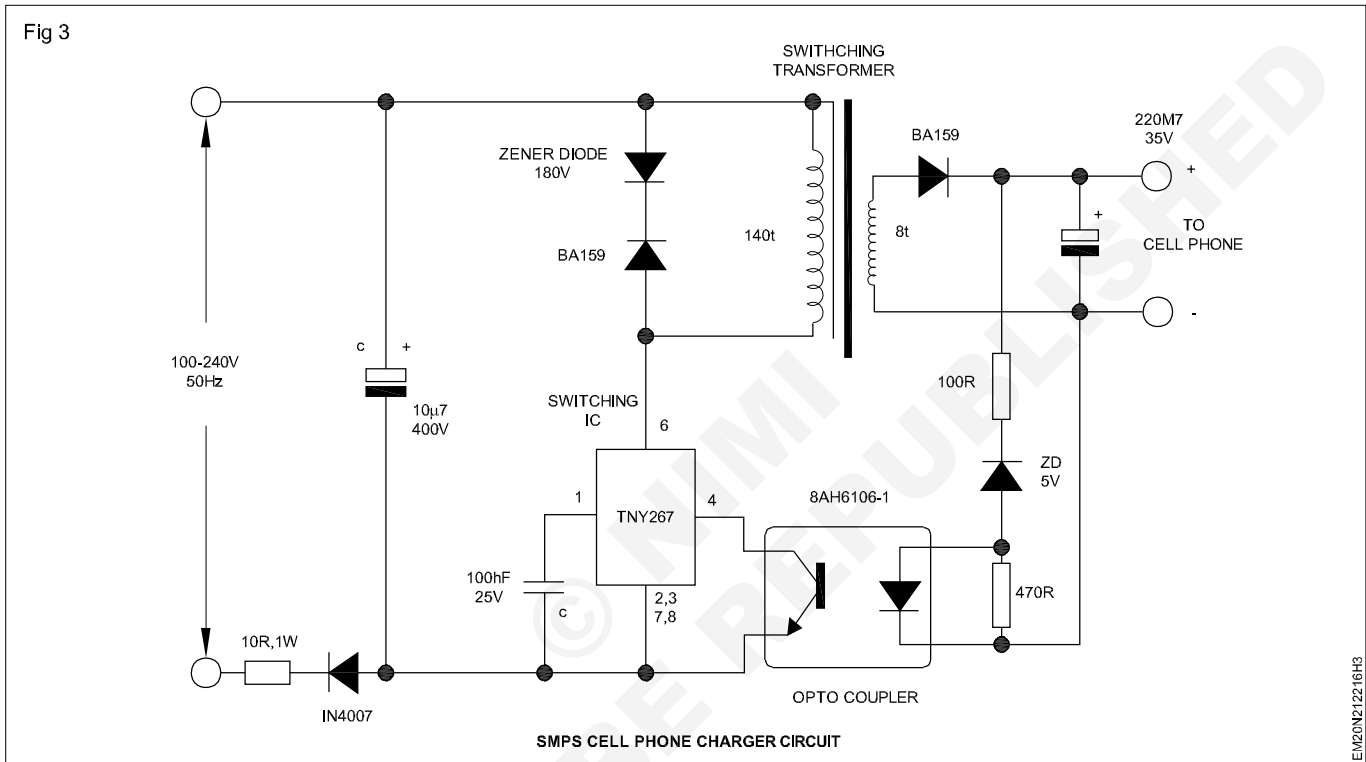
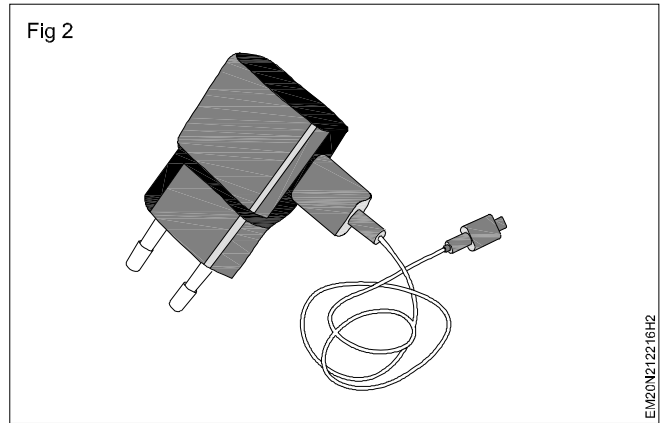
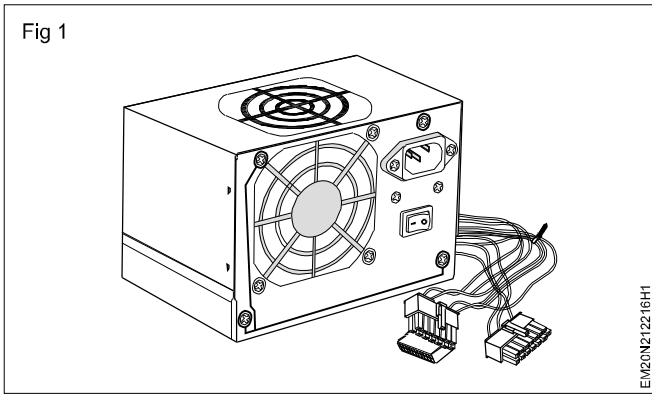

SMPS cell phone charger circuit

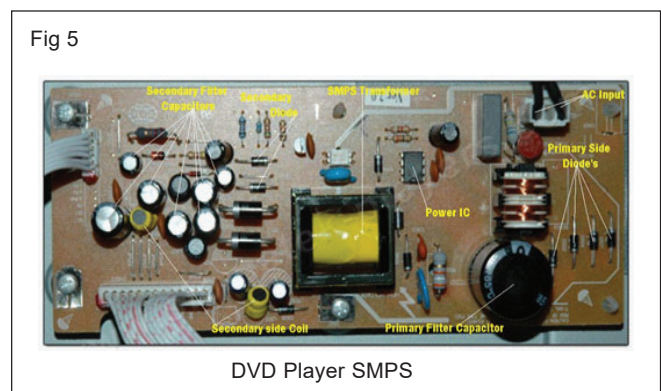
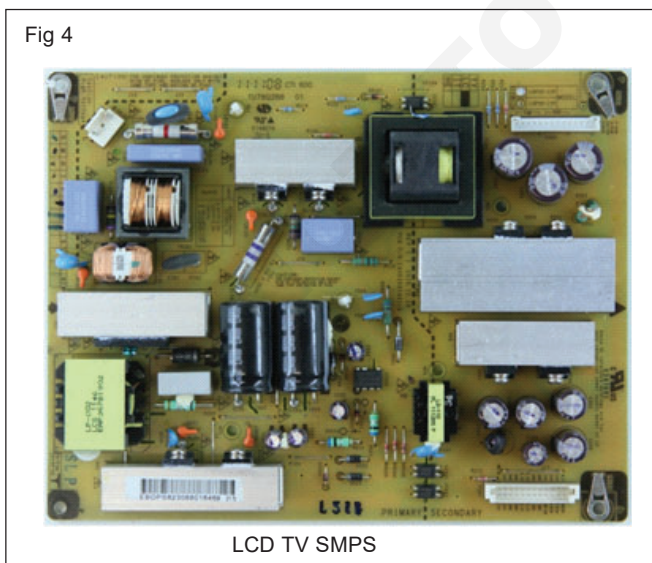
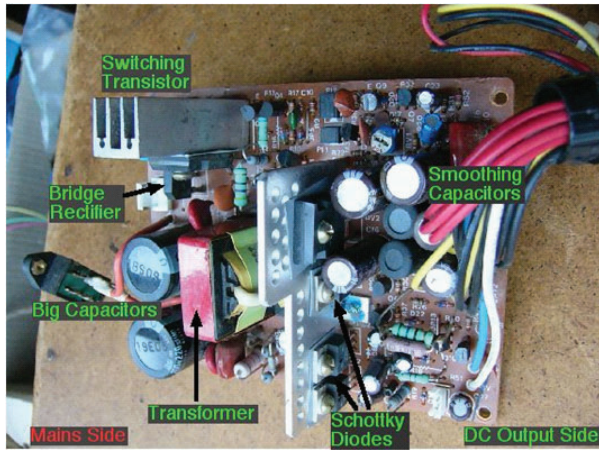

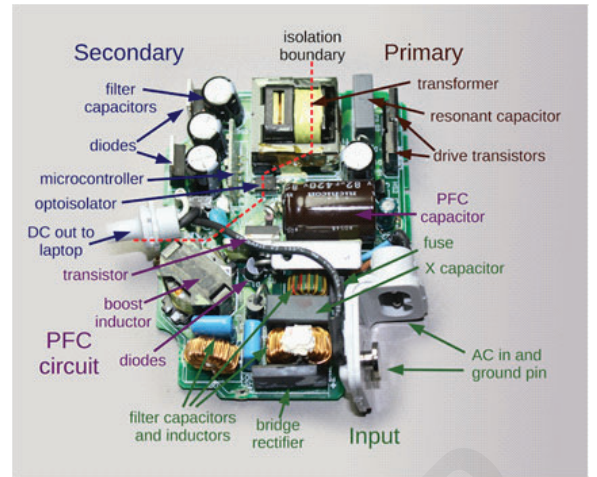

Fig 6



Computer SMPS

Fig 7



Laptop SMPS

11 Get the work checked by the Instructor.

© NIMI  
NOT TO BE REPUBLISHED

## Install and test the SMPS in PC

**Objectives :** At the end of this exercise you shall be able to

- install and test the SMPS unit in the given PC
- power ON the PC and check its working condition.

### Requirements

#### Tools / Equipments/ Instruments

- Trainees tool kit - 1 Set.
- Digital Multimeter - 1 No.

#### Materials/ Components

- Tested SMPS - 1 No.
- PC with all peripherals - 1 Set.

## PROCEDURE

### TASK 1 : Install the tested SMPS unit in the PC

- 1 Place the SMPS in the PC cabinet as shown in Fig.1 and screw it
- 2 By referring the layout diagram and with the help of tags & labels, place the connectors in appropriate locations.
- 3 Press firmly by holding the SMPS connectors to get proper contact with mother board and peripherals by referring Fig.2
- 4 Close the computer cabinet cover, by fixing door screws.
- 5 Get the work checked by the instructor.

### TASK 2 : Checking the working condition of PC with Power ON.

- 1 Connect the SMPS power cord to the mains and switch ON the supply
- 2 Switch ON the PC, wait few minutes for booting and check the display on the monitor.

Fig 1

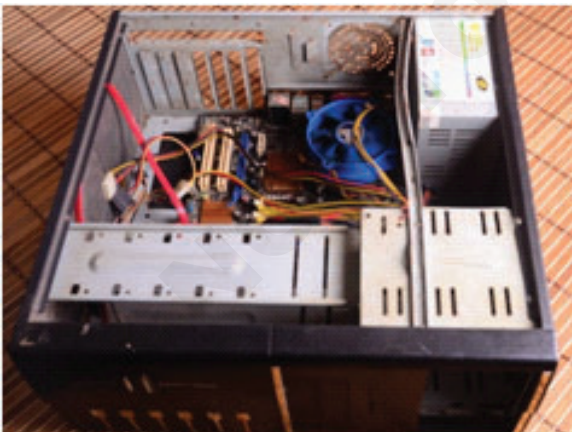
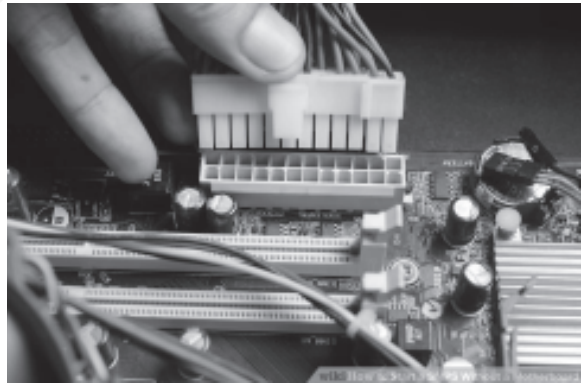

Fig 2



- 3 Get the work checked by the instructor.

**Install and test an inverter**

**Objectives :** At the end of this exercise you shall be able to

- connect the external battery to inverter unit
- test the inverter by connecting to mains power.

**Requirements**

**Tools / Equipments/ Instruments**

- Trainees tool kit - 1 Set
- Digital Multimeter with probes - 1 No.
- Line tester - 1 No.
- Hand gloves - 1 Set.
- Double ended spanner - as reqd.
- Inverter - 1 No.
- Battery, 12V, 150AH - 1 No.

**Materials/ Components**

- 240V/16A, SPST switch - 2 Nos.
- 240V/16A, 3Pin socket - 2 Nos.
- Connecting wires - as reqd.
- 100W/240V Test lamp - 1 No.

**Safety precaution**

- Do not make contact with both the battery terminals simultaneously with metal parts like screw driver, spanners and bare hand

- Sparking may occur during connection of battery cables to battery terminals.
- Use only the battery cables provided with the inverter unit to connect the external battery.

**PROCEDURE**

**TASK 1 : Connection of the external battery to the inverter unit**

- 1 Read the user manual of the given inverter unit and check the capacity of battery given for inverter.
- 2 Identify the colour code used for the battery cables and polarity marked on the terminals of the battery.
- 3 Select the red colour cable and terminals of the battery to the +Ve terminals of the UPS using bolt & nuts as shown in Fig 1.
- 4 Take the black colour cable from the UPS, connect it to the battery using bolt & nut as shown in Fig.

Fig 1

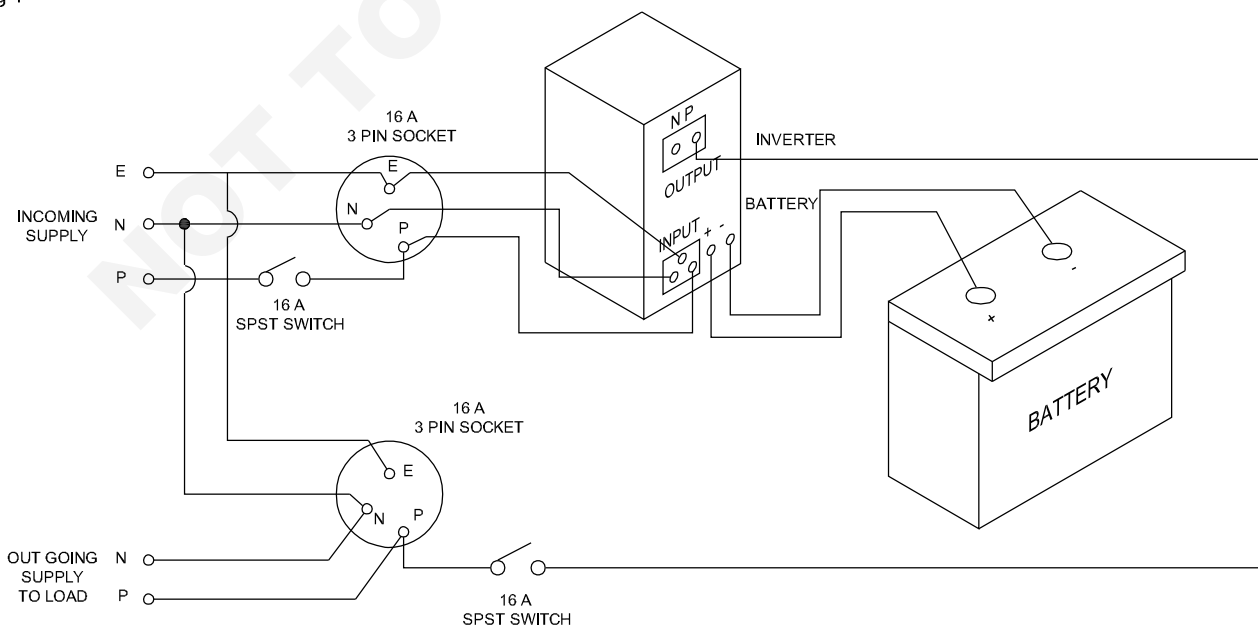

EM20N12218HT

- 5 Use double ended spanners, tighten the bolt & nuts with correct force.
- 6 Get the connections checked by the Instructor.

-----

**TASK 2: Testing the inverter by connecting to mains power and load**

- 1 Measure the voltage across the battery terminals, record the readings in Table-1.

**Note: Take care while handling 230V AC mains voltage.**  
**Ensure that the inverter start/Run switch is in OFF condition before doing output connection.**

- 4 Connect the test lamp across the output terminals, switch ON the UPS and observe the lamp is glowing.
- 5 Measure the AC voltage across the output of UPS, the DC voltage across the battery and record the readings in Table.
- 6 Switch OFF AC mains and measure output voltage battery voltage and record the readings in Table - 1

- 2 Connect the AC mains supply to the inverter unit through 16A, switch & socket by referring Fig.1
- 3 Connect the power cord of the inverter to the AC mains supply, switch ON and measure the DC voltage across battery terminals; record the readings in Table-1.

**Table-1**

AC input supply			AC output supply			Battery voltage			
P-N	P-E	N-E	P-N	P-E	N-E	UPS OFF AC OFF	UPS OFF AC ON	Load ON AC ON	Load ON AC OFF

- 7 Get the work checked by the Instructor and Switch OFF the UPS.

-----

**Troubleshoot the fault in the given inverter unit, rectify the defects and verify the output with load**

**Objectives :** At the end of this exercise you shall be able to

- identify the faulty components/section in the inverter
- rectify the defects in the inverter unit
- verify the output with load.

Requirements			
Tools / Equipments/ Instruments		Materials/ Components	
• Trainees tool kit	- 1 Set	• Defective inverter with battery	- 1 No.
• Digital multimeter with probes	- 1 No.	• Test lamp with 230V, 100W bulb	- 1 No.
• Line tester	- 1 No.	• Sketch pen	- 1 No.
• Magnifying glass	- 1 No.		
• Oscilloscope, 100MHz	- 1 No.		

**PROCEDURE**

**TASK 1 : Identification of the faulty components/section in the inverter**

- |  |  |
|--|--|
| <ol style="list-style-type: none"> <li>1 Open the inverter cover and carry out the visual inspection of the board and connectors with the help of magnifying glass.</li> <li>2 Identify if any damaged components or connectors are seen.</li> <li>3 Remove the damaged component and check the condition</li> <li>4 Trace the circuit by referring the circuit diagram (Fig.1) and identify the sections</li> </ol> | <ol style="list-style-type: none"> <li>5 Mark the different test points by using sketch pen.</li> <li>6 Apply supply to the inverter unit and measure voltage at marked test points.</li> <li>7 Observe the waveforms using CRO at switching device input/output</li> <li>8 Record the measured readings in the table-1</li> </ol> |
|--|--|

**Table - 1**

Section	Test point	Description	Voltage
Battery	TP1	Battery voltage	
Inverter	TP2 TP3	Inverter feedback voltage from inverter output transformer Rectified feedback DC voltage	
PWM section	TP3 TP5	Sensed DC Voltage to PWM section Trigger pulse from PWM IC to upper switching device (AC)	
Switching section	TP7 TP8	Output AC waveform of upper switching device (AC) Output AC waveform of lower switching device (AC)	
Inverter output	TP9	Inverter output voltage (also observe output waveform)	

9. Get the work checked by the Instructor

**TASK 2: Rectification of the defects in the inverter unit**

- 1 Based on the observed readings obtained from the marked test points and waveforms, identify the faulty section/component in the inverter.
- 2 Remove the suspected component from PCB and test it.
- 3 Replace the defective components.
- 4 Get the work checked by the Instructor.

— — — — —

**TASK 3: Verification of the output terminal with lamp load**

- 1 Connect a 240V, 100W lamp load at the output terminal
- 2 Switch ON the inverter, observe the lamp light
- 3 Measure the output AC voltage and confirm that it remains constant.
- 4 Get the work checked by the instructor

— — — — —

© NIMI  
NOT TO BE REPUBLISHED

**Construct and test IC based DC to DC converter for different voltages**

- Objectives :** At the end of this exercise you shall be able to
- construct and test IC based 5V to 12V step up converter
  - construct and test IC based 9V to 5V step-down converter.

<b>Requirements</b>			
<b>Tools / Equipments/ Instruments</b>			
• Trainees tool kit	- 1 Set.	• IC LT 1073-12	- 1 No.
• Regulated DC Power supply 0-30V/2A	- 1 No.	• IC LT 1073-5	- 1 No.
• Digital multimeter with probes	- 1 No.	• Schottky diode 1N5818	- 1 No.
<b>Materials/ Components</b>		• Resistor, 50Ω	- 1 No.
• Bread board/General purpose PCB	- 1 No.	• Resistor 220Ω	- 1 No.
		• Inductor, 150μH	- 1 No.
		• Capacitor, 100μF/25V	- 2 Nos.
		• Hook-up wires	- as reqd.

**PROCEDURE**

**TASK 1 : Construction and testing IC based 5V to 12V step up converter**

- 1 Collect the components and check them for its good working condition
- 2 Connect the components and construct a 5V to 12V step up convertor by referring the circuit diagram (Fig.1)
- 3 Set the power supply voltage to + 5V DC and apply to the circuit.
- 4 Measure and record the input and output voltage in table-1
- 5 Measure the pin voltages of IC and voltage across inductors, and diode in the circuit unit record in Table - 1

**Once the supply is switched ON check if any components or the IC LT1073 is getting heated - up; if yes, switch OFF DC supply and check the circuit.**

<b>Voltage across inductor</b>	<b>Voltage across diode</b>

**Table - 1**

<b>Input DC Voltage</b>	<b>Output DC voltage</b>	<b>IC pin voltages</b>					
		<b>I<sub>LIM</sub></b> (PIN-1)	<b>V<sub>IN</sub></b> (PIN-2)	<b>SW<sub>1</sub></b> (PIN-3)	<b>SW<sub>2</sub></b> (PIN-4)	<b>GND</b> (PIN-5)	<b>FB/SENCE</b> (PIN-8)

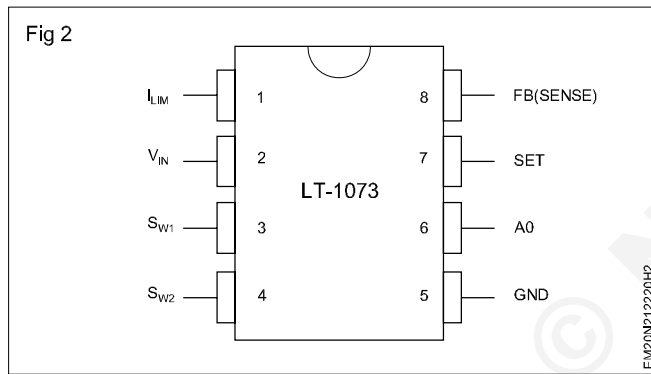
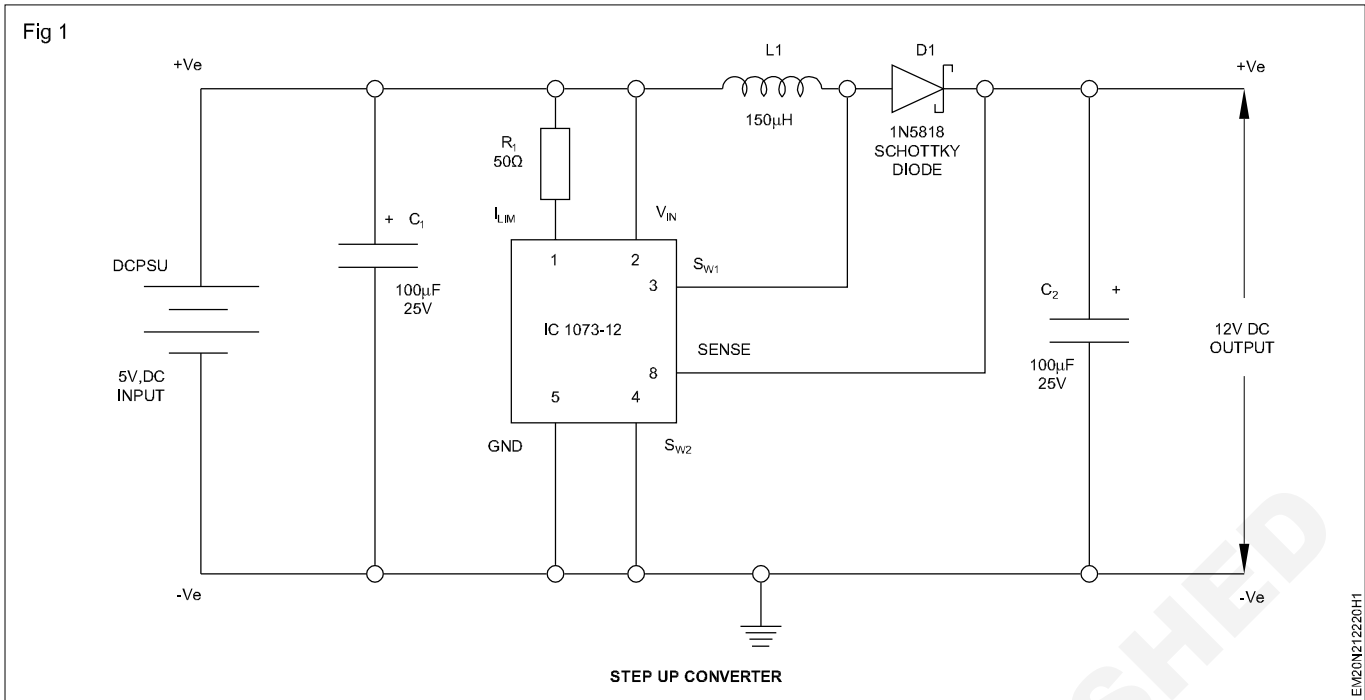

6 Get the work checked by the instructor.

### TASK 2 : Construction and testing IC based 9V to 5V step-down converter

- 1 Replace the Step-up converter IC with LT-1073-5
- 2 Modify the step-up converter circuit into step-down converter by referring the circuit diagram (Fig.1)
- 3 Set the power supply voltage to +9V DC and apply to the circuit.
- 4 Measure and record the input and output voltage of step-down converter in table-2.
- 5 Measure the pin voltages of IC and voltage across inductor, and diode in the circuit and record in table-2.

Table - 2

Input DC voltage	Output DC voltage	IC PIN voltage						Voltage across inductor	Voltage across diode
		$I_{LIM}$ (PIN-1)	$V_{IN}$ (PIN-2)	$SW_1$ (PIN-3)	$SW_2$ (PIN-4)	GND (PIN-5)	SENSE (PIN-8)		



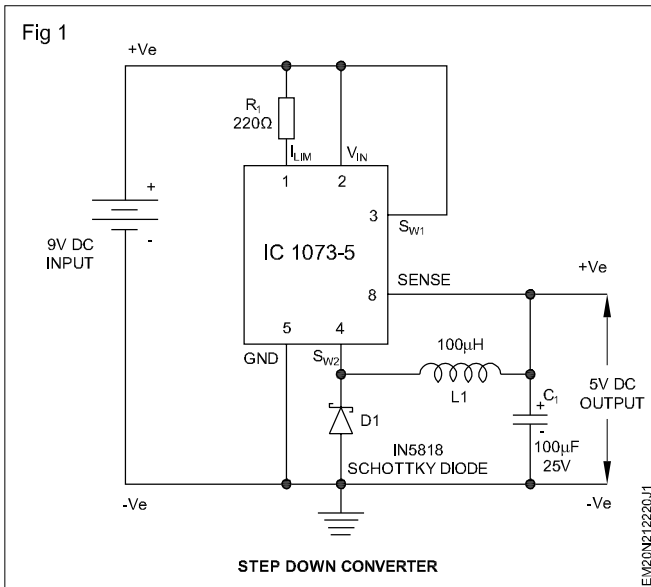

6 Get the work checked by the instructor.

-----

**Construct and test a switching step down regulator using LM 2576**

**Objectives :** At the end of this exercise you shall be able to  
 • **construct and test the regulated power supply using IC LM 2576.**

Requirements	
<b>Tools/Equipments/Instruments</b> <ul style="list-style-type: none"> <li>Regulated DC Power supply (0-30V/2A) - 1 No.</li> <li>Digital multimeter with probes - 1 No.</li> <li>Trainees tool kit - 1 Set.</li> <li>Soldering iron 25W/230V - 1 No.</li> <li>Semiconductor/IC LM 2576 data sheet - as reqd.</li> </ul>	<b>Materials/Components</b> <ul style="list-style-type: none"> <li>IC LM2576 (5V) - 1 No.</li> <li>Inductor 100µH 2 Amps - 1 No.</li> <li>Diode 1N5822 - 1 No.</li> <li>Capacitor 1000µF/16V, 100µF/63V - 1 No each.</li> <li>Breadboard/PCB-GP - 1 No.</li> <li>Hook up wire - as reqd.</li> <li>Rosin cored solder - as reqd.</li> </ul>

**PROCEDURE**

**TASK 1 : Construction and test the regulated power supply using LM 2576**

- 1 Collect all the components, required and check them.
- 2 Refer to the data sheet of the IC 2576, identify pins and test the condition.
- 3 Prepare the layout on the GPCB and assemble the circuit as per the diagram shown in Fig 1&2.
- 4 Get the assembled circuit checked by the Instructor.

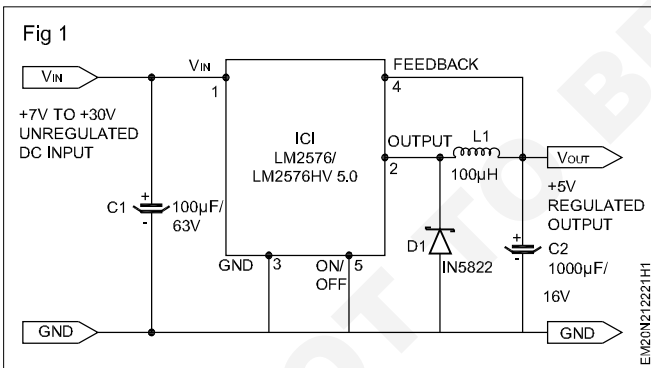

- 5 Switch ON the DC supply to the input DC voltmeter across the output.
- 6 Increase the input voltage from 7V upto 30V in steps of 5 Volts.
- 7 Note down the corresponding output voltage and record the readings in TABLE 1.

**Ensure that the output voltage remains constant.**

**Table 1**

Sl. No.	Input voltage	Output voltage
1	5V	
2	10V	
3	15V	
4	20V	
5	25V	
6	30V	

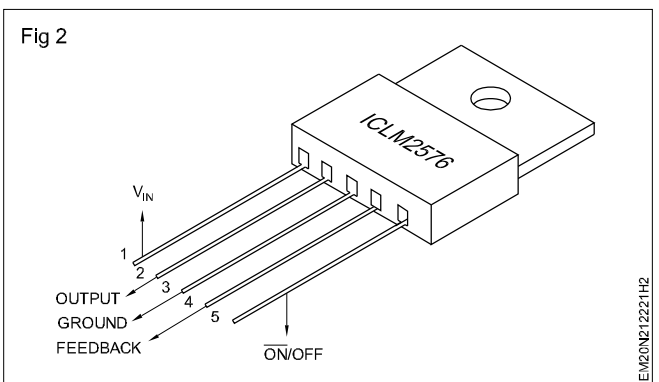

- 8 Get the work checked by the instructor.

**Construct and test a switching step up regulator using MC34063**

**Objective :** At the end of this exercise you shall be able to

- construct and test the step up regulated power supply using IC MC34063.

Requirements	
<b>Tools/Equipments/ Instruments</b> <ul style="list-style-type: none"> <li>• Regulated DC Power supply unit 0-30V/2A - 1 No.</li> <li>• Trainees toolkit - 1 set.</li> <li>• Digital multimeter with probes - 1 No.</li> <li>• Data sheet of the IC MC34063 - as reqd.</li> <li>• Soldering iron 25W/230V - 1 No.</li> </ul>	<b>Materials/ Components</b> <ul style="list-style-type: none"> <li>• IC MC34063 - 1 No.</li> <li>• Resistor CR25 (0.22Ω, 180Ω, 1.5k, 12kΩ) - 1 No each.</li> <li>• Inductor 100μH - 1 No each.</li> <li>• Diode MBR 340 - 1 No.</li> <li>• Capacitor (100μF/25V, 0.001μF, 2200μF/25V) - 2 Nos.</li> <li>• Trimmer pot 1KΩ - 1 No.</li> <li>• Bread board/PCB-GP - 1 No.</li> <li>• Hook up wire - as reqd.</li> <li>• Rosin core solder - as reqd.</li> </ul>

**PROCEDURE**

**TASK 1 : Construction and testing of regulated power supply**

- 1 Collect all components required and check them for good condition.
- 2 Refer to the data sheet of the IC MC34063, identify pin number, test them.
3. Prepare the layout on the GPCB and assemble the circuit as per the diagram shown in Fig 1 & 2.
- 4 Get the assembled circuit checked by the Instructor.

**Ensure that the output voltage remains constant.**

**Table 1**

Sl. No.	Input voltage	Output voltage
1	5V	
2	10V	
3	15V	
4	20V	
5	25V	
6	30V	

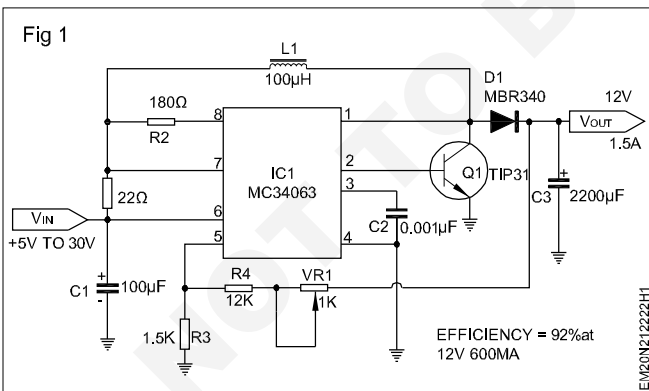

- 5 Switch ON the DC power supply to the input and connect DC voltmeter across the output.
- 6 Increase the input voltage from 5V upto 30V in steps of 5 volts.
- 7 Note down the corresponding output voltage and record the readings in TABLE 1.

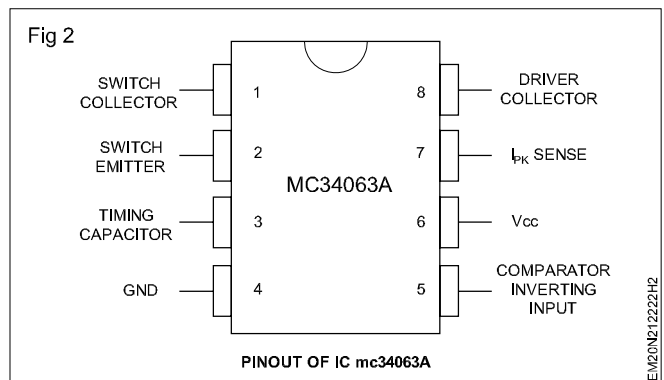

- 8 Get the work checked by the instructor.

**Connect battery stack to the UPS**

**Objectives:** At the end of the exercise you shall be able to  
 • **interconnect the batteries to prepare and test a battery stack for the UPS.**

Requirements	
<b>Tools /Equipments/ Instruments</b>	<b>Materials/ Components</b>
<ul style="list-style-type: none"> <li>• Trainees tool kit - 1 Set.</li> <li>• Safety gloves - 1 No.</li> <li>• Digital multimeter with probes - 1 No.</li> <li>• Single phase UPS, 6KVA - 1 No.</li> <li>• Double ended spanners - as reqd.</li> </ul>	<ul style="list-style-type: none"> <li>• 100W/ 230V/test lamp - 1 No.</li> <li>• Battery 12V, 40AH - 13 Nos.</li> <li>• Operating manual - 1 No.</li> <li>• Battery connecting wires - as reqd.</li> <li>• Bolt &amp; Nuts for battery - as reqd.</li> <li>• cable connection - as reqd.</li> <li>• Rack for battery - as reqd.</li> </ul>

**PROCEDURE**

**TASK 1 : Interconnection of batteries to prepare a battery stack for the UPS**

- 1 Read the operating manual of the UPS and find the required battery back up voltage & current rating.
- 2 Calculate to the required level of voltage/current, arrange the batteries on the battery rack.

**Electrical hazard: Do not make contact with both of the battery terminals simultaneously with metal parts like screw driver or spanners.**

- 3 Prepare and place the battery connecting cables
- 4 Check the battery voltage individually and confirm its good working condition.

- **For series connection of batteries -ve terminal of one battery should be connected with +ve terminal other battery by referring Fig 1.**
- **For parallel connection of series stack of batteries connect +ve and -ve terminals of one series battery stack to the +ve and -ve terminal of the another series battery stack by referring Fig 2.**
- **Sparking may occur during connection of battery cables to battery terminals.**
- **Use only the battery cables provided with the unit to connect the external battery. Do not exted the length of these cables.**

- 5 Connect the cable terminals of battery to the +ve and -ve terminal of the UPS carefully.

- **Do not interchange the polarity**
- **Do not connect the battery stack to the UPS directly. First charge the UPS filter capacitor through a incandescent lamp (Fig.3) and then connect the battery stack.**

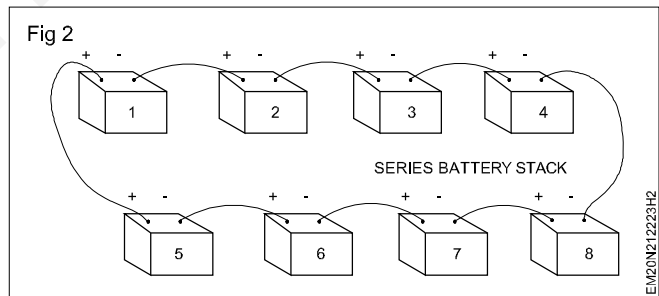
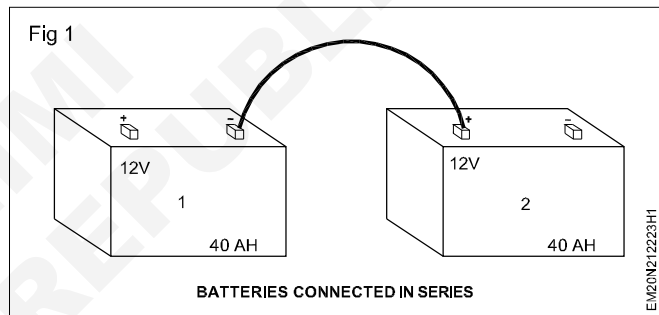

- 6 Check the battery voltage Fig.3 at the battery connector of the UPS.
- 7 Close the rear side cover and get the work checked by the instructor

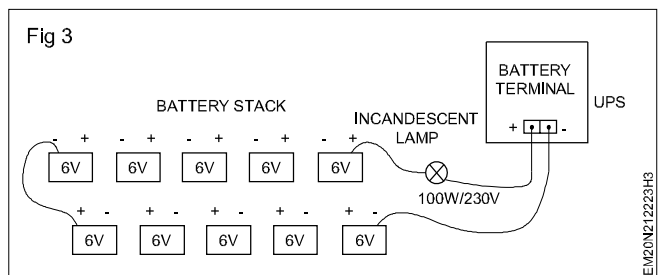

- 8 Get the work checked by the Instructor.

**Identify front panel controls & indicators of UPS**

**Objectives :** At the end of this exercise you shall be able to

- identify front panel indicators of UPS
- identify different sockets and connectors on the rear panel on the rear panel of UPS.

Requirements			
Tools / Equipments/ Instruments		Materials/ Components	
• Trainees tool kit	- 1 Set.	• Cotton waste	- as reqd.
• Single phase UPS, 6KVA with manual	- 1 No.		

**Safety precaution**  
**1 Keep the place dry and clean**

**PROCEDURE**

**TASK 1 : Identify front panel indicators of UPS**

- 1 Note down and record the specifications of the UPS.
- 2 Draw the sketch of front panel of the UPS with all indicators and switches
- 3 Identify each indicator and control on the front panel by referring to Fig.1/ Operating manual.
- 4 Record the observations in Table-1
- 5 Repeat the above steps for all indicators and controls on the front panel and record them.
- 6 Referring to the manual, record a brief function of the switches and the indicators.

**Table - 1**

Sl.No.	Name of the indicator/control	Purpose
1		
2		
3		
4		
5		

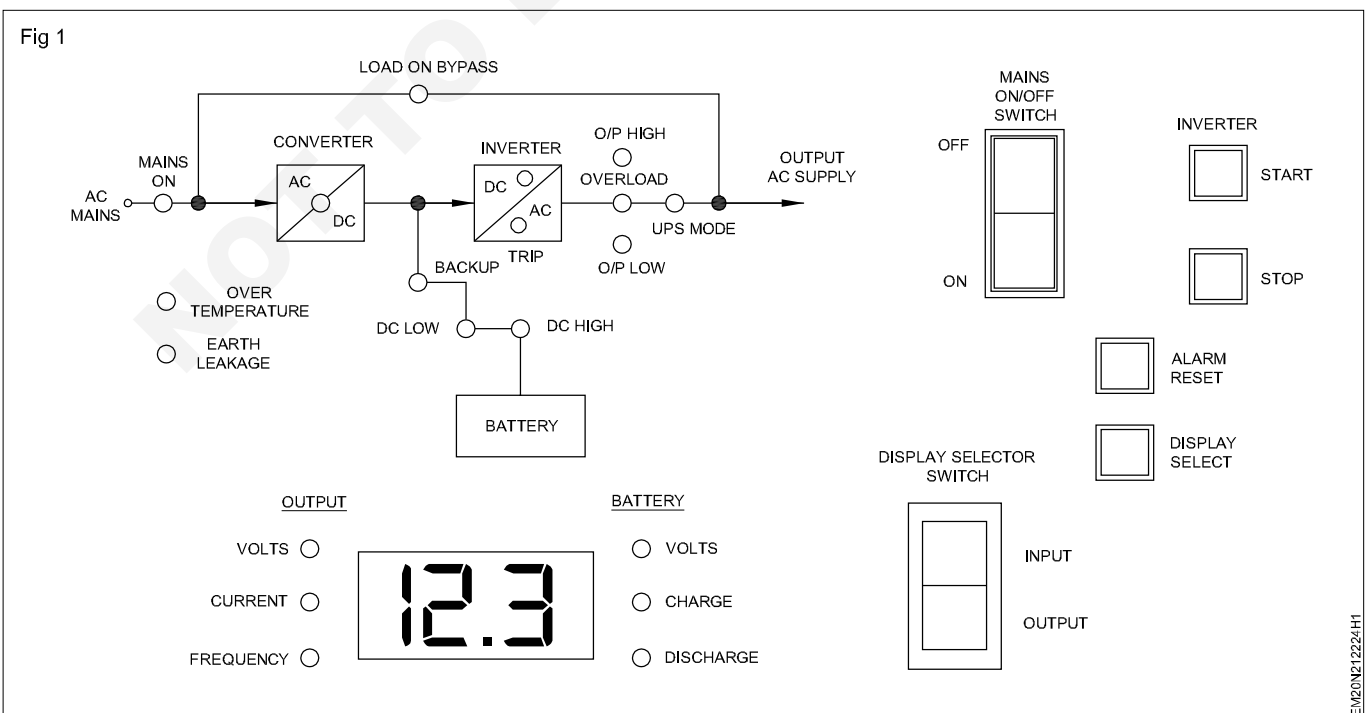

**TASK 2: Identification of different sockets and connectors on the rear panel of UPS**

- 1 Turn the rear panel of the UPS and identify the name of unit, record its socket and connector available in rear panel with the help of operation/Instruction manual.
- 2 Find out each socket in the UPS, note down in the Table-2.
- 3 Repeat the above steps for all sockets and connectors and note down in Table-2.

**Table 2**

SI.No.	Name of the Sockets/Connectors	Purpose

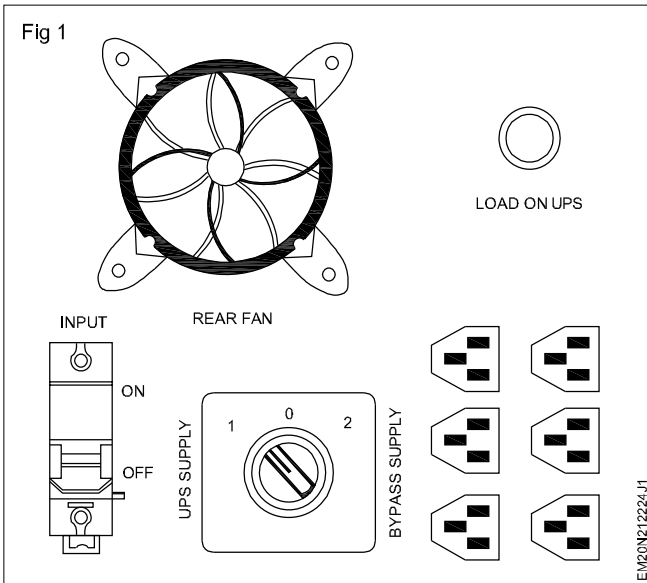

- 4 Get the work checked by the Instructor.

**Connect battery & load to UPS & test on battery mode**

**Objectives :** At the end of this exercise you shall be able to

- **measure the total voltage of the battery stack using voltmeter**
- **connect the UPS and load test the battery.**

<b>Requirements</b>			
<b>Tools / Equipments/ Instruments</b>			
• Trainees tool kit	- 1 Set.	• UPS of 5 KVA with battery stack	- 1 Set.
• Safety gloves	- 1 Set.	• Double ended spanner 10mm	- 2 No.
• Voltmeter 0-600V	- 2 Nos.	<b>Material/ Components</b>	
• Digital multimeter with probes	- 1 No.	• 100W/230V Test lamp with holder	- as reqd.

**PROCEDURE**

**TASK 1 : Measurement of the total voltage of the battery stack using voltmeter**

**Safety**

**Electrical hazard: Do not make contact with both of the battery terminals simultaneously with metal parts like screw drivers or spanners.**

**Sparking may occur during connection of battery cables to may burn the skin seriously.**

- 5 Note down the first label of the battery stack, connect the DC voltmeter to the battery as shown in the Fig.2
- 6 Measure the voltage of the battery and note down the observed voltage on table-1.
- 7 Repeat step 4 to 6 for measuring the voltage on all the batteries

- 1 Disconnect the battery stack from main supply and remove the cable from main switch to the battery.
- 2 Prepare labels serially from 1 to N and paste them on each of the batteries
- 3 Get the work checked by the Instructor.
- 4 Connect the DC voltmeter across battery stack as shown in the Fig.1, and note down the observation in the Table-1.

**Note: In case any variation in measured voltage of the batteries, record in the remarks column**

- 8 Add all the voltages from label - 1 to N compare with the stack voltage.

Voltage across battery stack.....V

**Table 1**

SI.No.	Label No	Measured voltage	Remarks
1	Battery 1		
2	Battery 2		
3	Battery 3		
4	Battery 4		
5	Battery 5		
N	Battery N		
	<b>Total voltage of stack</b>		

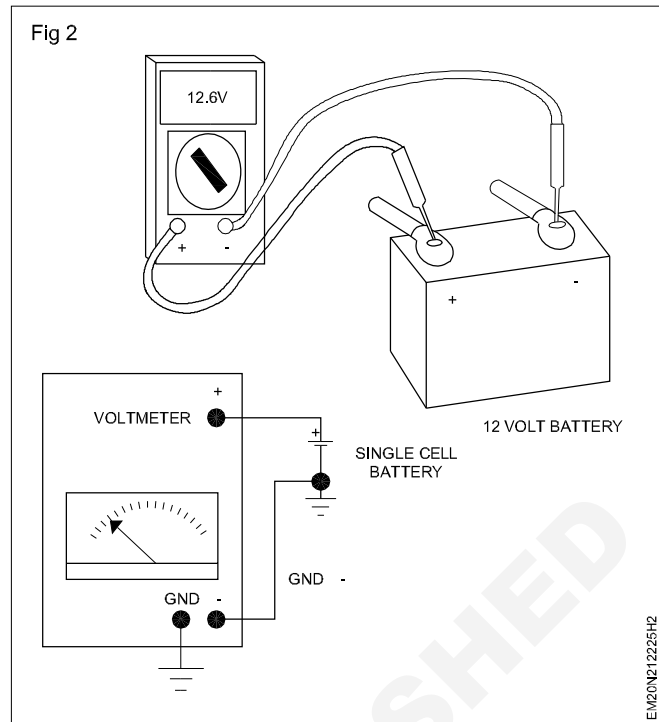
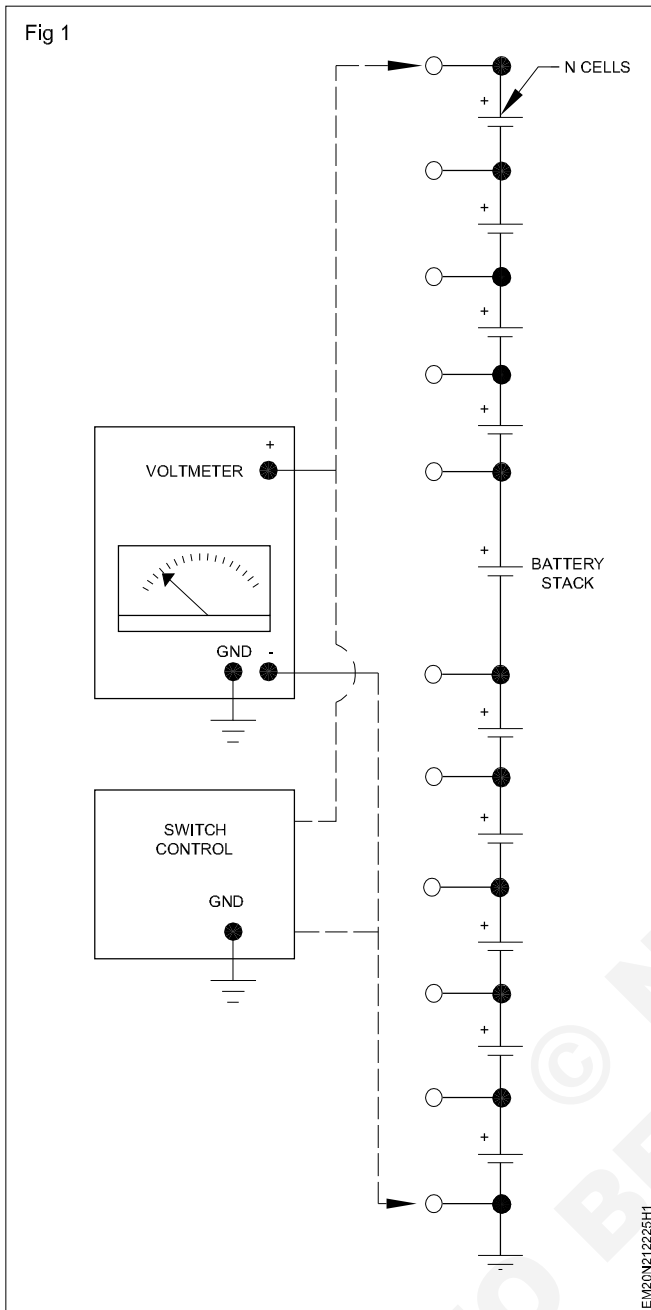

10 Get the work checked by the Instructor.

## TASK 2: Connection of UPS and load testing of the battery

### Safety precaution

- 1 Before connecting the battery to the UPS, verify the electrode terminals symbol/ colour codes on the battery
- 2 Ensure that the UPS is kept in switched OFF condition
- 3 Connect the leads with correct polarity and tighten them.

- 1 Check the battery voltage (for 12V battery minimum voltage from 9.5V to 12V)
- 2 Take out the terminals of the battery cable from the UPS.

- 3 Observe the colour code of the cable and tightly connect the battery with correct polarity.
- 4 Connect the DC voltmeter across the battery, measure the voltage and record the observation in Table-2 as no load voltage.
- 5 Connect two lamps in parallel as full load to the UPS output as shown in Fig 3 (Keep the lamps safely as the heat may damage the surface - avoid it).
- 6 Keeping the voltage probes across the battery, switch ON the UPS, observe the readings on the meter.
- 7 Record the observations in table-2 as voltage with full load



8 Remove on lamp and repeat the step as light load.

Table 2

SI.No	Status of UPS	Battery voltage		Full load(200W)
		No load	Light load (100W)	
1	UPS OFF			
2	UPS ON			

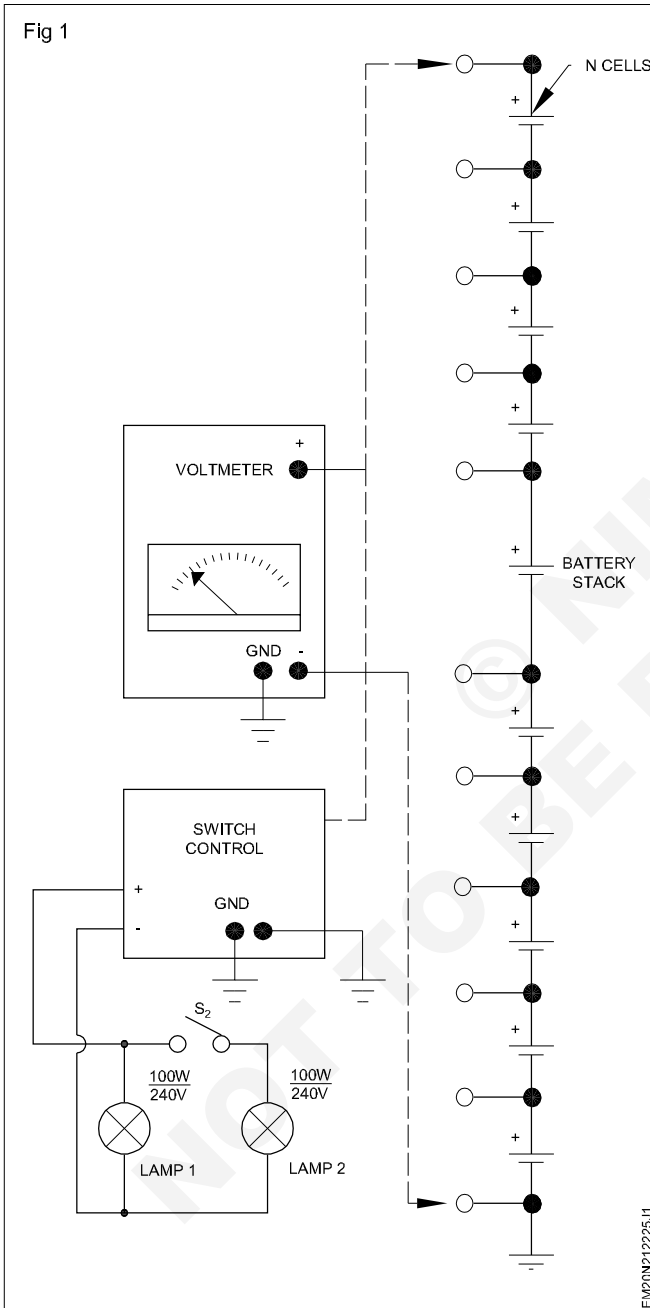

9 Get the work checked by the Instructor

-----

**Open top cover of a UPS; identify its isolation transformers, the UPS transformer and various circuit boards in UPS**

**Objectives :** At the end of this exercise you shall be able to

- identify the major section in UPS
- identify the components used in UPS.

Requirements	
<b>Tools/Equipments/ Instruments</b> <ul style="list-style-type: none"> <li>• UPS (650 VA) - 1 Set.</li> <li>• Trainees tool kit - 1 Set.</li> </ul>	<b>Material/ Components</b> <ul style="list-style-type: none"> <li>• Nil</li> </ul>

**Note:** The instructor has to label the major components/parts and sections of the UPS

**PROCEDURE**

**TASK 1 : Identification of major sections in UPS**

- 1 Disconnect the power cable from the mains supply. Remove the screws that are present in the side panel and open the UPS unit as demonstrated by the instructor as shown in Fig 1.

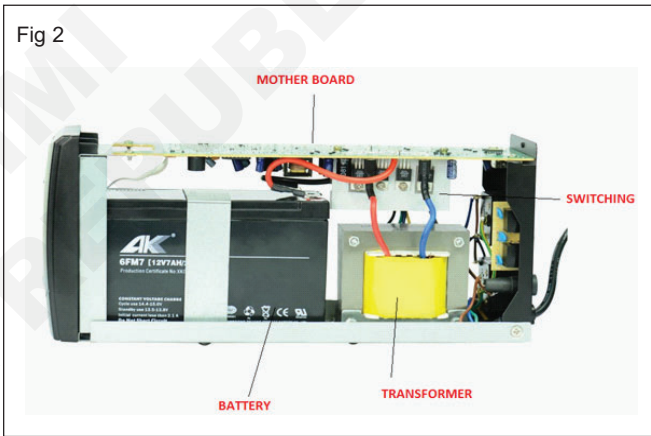
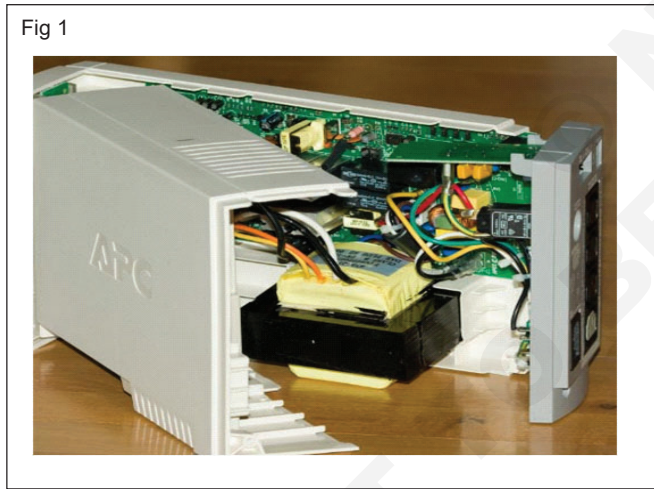

- 2 Unscrew the battery clamp pull out/ remove the battery terminal connectors and take out the battery.

**Before opening CPU case touch cabinet outer cover to discharge ESD power.**

- 3 Note down the wirings and carefully lift the circuit board. Remove from its position.
- 4 Find out the major section in UPS as shown in Fig 2. Note down your observations in TABLE 1.

**Table 1**

SI.No.	Major section in UPS
1	
2	
4	
5	
6	

- 5 Get the work checked by the instructor.

**TASK 2 : Identification of components used in UPS**

- 1 Remove the circuit board(PCB) from the UPS cabinet.
- 2 Identify the listed components in the circuit board as shown in Fig 1. Record the label of the identified components in TABLE 2 by referring to related theory
- 3 Repeat steps for all the other major components.

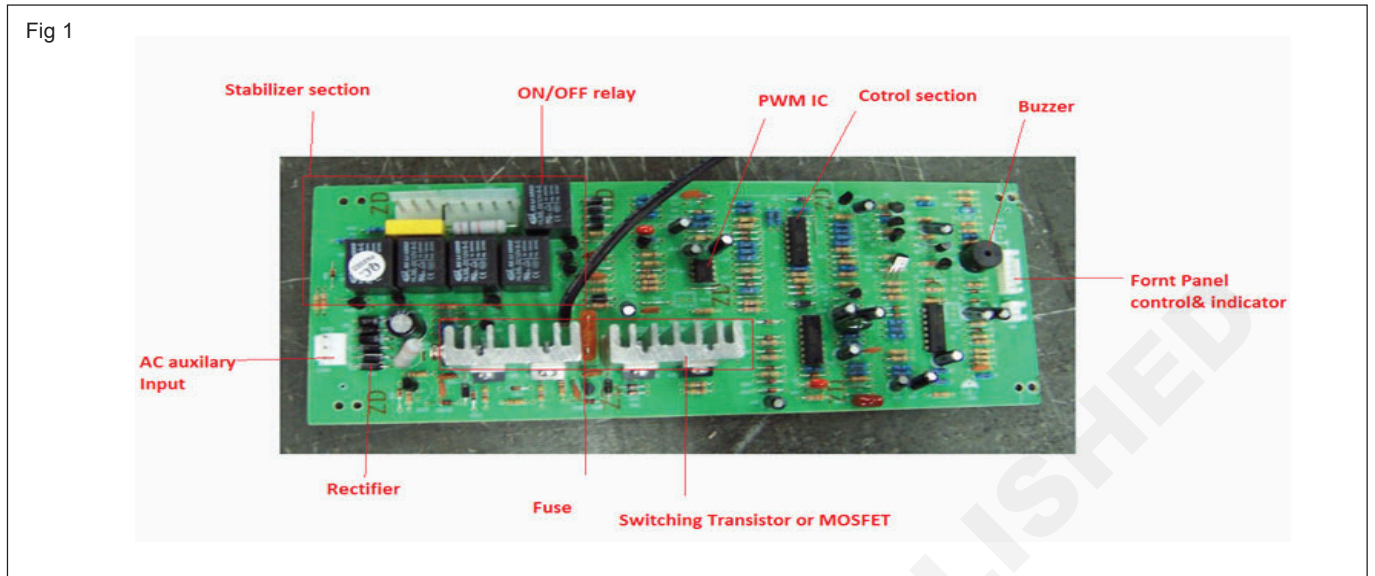

**Table 2**

SI.No.	Name of sections	Components/Parts/Devices	Remarks
1			
2			
3			
4			
5			
6			
7			
8			
9			
10			

- 4 Get the work checked by the instructor.

-----

**Identify the various test points and verify the voltages on the UPS**

**Objective :** At the end of this exercise you shall be able to  
 • **measure the voltage at various test points of the UPS.**

<b>Requirements</b>			
<b>Tools/Equipments/Instruments</b>		<b>Materials/Components</b>	
• Trainees tool kit	- 1 Set.	• Safety gloves	- 1 Set.
• Digital multimeter with probes	- 1 No.	• UPS with battery	- 1 Set.
		• and instruction manual	- 1 Set.

**Note:** Remove the power cord from the AC mains supply before starting this task.  
 The Instructor has to mark the test points numbers using permanent marker pen.

**PROCEDURE:**

**TASK 1 : Measurement of the voltages at various test points of UPS**

- 1 Open the UPS unit as demonstrated by the instructor.
- 2 Identify the major components/devices and sections on the assembled circuit board of UPS.
- 7 Select the DC voltage function on multimeter and measure the rectifier voltage and note down in Table 1.
- 8 Measure the battery voltage by referring the Fig 1 and note down in Table 1.

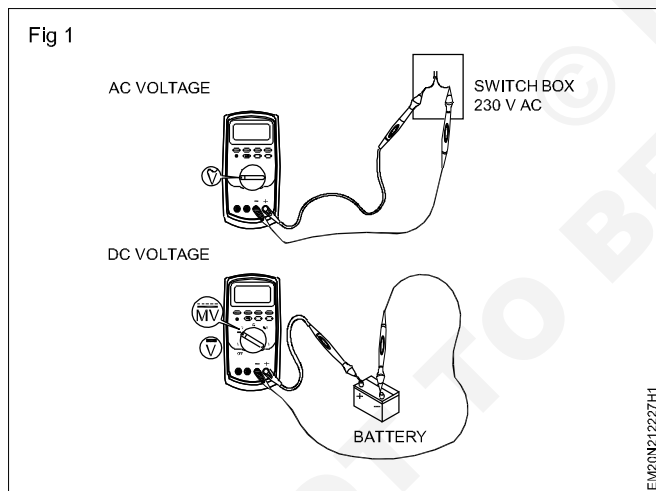

**Table 1**

<b>Sl.No.</b>	<b>Name of the test point</b>	<b>Voltage</b>	<b>Remarks</b>
1	AC input supply		
2	Transformer secondary		
3	Rectifier output		
4	Battery voltage		
5	UPS output		
6			
7			

- 3 Draw the sketch of layout of the sections and mark the major/important test points in each section.
- 4 Connect the power cord to mains supply and switch ON the UPS.
- 5 Measure the AC input voltage in the wall socket as shown in Fig 1.
- 6 Measure the voltage at transformer output section and the readings in Table 1.
- 9 Get the work checked by the Instructor.

**Identify various circuit boards in UPS and monitor voltages at various test points**

**Objectives:** At the end of the exercise you shall be able to

- identify various sections of UPS and locate test points on the circuit boards
- measure the voltage/waveform at various circuit boards in UPS.

Requirements			
Tools/Equipments		Materials/Components	
• Trainees tool kit	- 1 Set.	• UPS with battery	- 1 Set.
• Digital multimeter with probes	- 1 No.	• Safety gloves	- 1 Set.
• CRO 0-20MHz - dual channel		• UPS with battery and mark	- 1 Set.

**Note:** The Instructor has to select and mark number of test points in each section based on the importance/functions on the UPS available in Lab.

**PROCEDURE**

**TASK 1 : Identifying various sections of UPS and locate test points on the circuit boards**

- 1 Keep the power cord disconnected from mains supply and open the UPS unit as demonstrated by the instructor.
- 2 Identify the major sections on the circuit the boards of UPS referring circuit (Fig.1)
- 3 Trace the circuit and identify/ locate the test points on the UPS by referring to the circuit diagram and record them in Table 1.
- 4 Mark the test points on each board/section using sketch pen.
- 5 Connect AC mains supply to UPS and measure test point voltages of each section and record in Table 2.
- 6 Prepare the CRO for measurements and check the output waveform at the oscillator section.
- 7 Get the work done checked by the Instructor.



**Table 1**

Type of UPS		
Sl.No.	Name of the Board/Section	Purpose

**TASK 2 : Measurement of the voltage/waveform at various circuit boards in UPS**

**Table 2**

Name of the Section	Test Point number	Description/ Function of the section/circuit	Voltage/ waveform	Remarks
Mains to Inverter change over section Battery status indicator section Oscillator and driver section	TP-1	AC mains input		
	TP-2	Rectified DC output		
	TP-3	Battery voltage		
	TP-4	Battery status indicator section		
	TP-5	Input to regulator IC		
	TP-6	Regulator IC output		
	TP-7	Oscillator out voltage (AC) (observe waveform using CRO)		
	TP-8	Triggering pulse input to upper bank driver (AC)		
	TP-9	Triggering pulse input to upper bank driver (AC)		
	TP-10	Triggering pulse input to upper bank switching transistor (AC)		
	TP-11	Triggering pulse input to lower bank switching transistor (AC)		
Inverter section	TP-12	DC input to inverter section (upper bank)		
	TP-13	DC input to inverter section (lower bank)		
	TP-14	Output inverter voltages at transformer secondary tapings		
	TP-15			
	TP-16			
	TP-17			
	TP-18			
	TP-19			

8 Get the work checked by the Instructor.

**Perform load test to measure backup time**

**Objectives:** At the end of the exercise you shall be able to  
 • **perform load test to measure backup time.**

<b>Requirements</b>		
<b>Tools/Equipments/Instruments</b>		<b>Materials/Components</b>
• Trainees tool kit	- 1 Set.	• 100W/240V incandescent lamp (Test lamp)
• Computer UPS (around 600VA) with operating instruction manual	- 1 No.	• 12V/7AH, maintenance free rechargeable battery
• DMM with probes	- 1 Set.	- 1 No.
• Voltmeter 0-30VDC	- 1 No.	- 1 No.
• Safety gloves	- 1 Pair.	
• Stop watch	- 1 No.	

**Safety precaution**  
**1 Before connecting the battery to UPS, inspect the electrode terminals for symbols/ colour codes on the battery.**

**2 Ensure that the UPS is kept in switched OFF condition**  
**3 Connect the leads with correct polarity and tighten them.**

**PROCEDURE**

- 1 Use Dc voltmeter measure the terminal voltage and verify with the specification on the battery.
- 2 Take out the terminals of the battery cable from the UPS.
- 3 Observe the colour code of the cables and tightly connect the battery with correct polarity.
- 4 Connect the DC voltmeter across the battery, measure the voltage and record the observation in Table-1 as no load voltage.
- 5 Connect the lamp load to the UPS output as shown in Fig 1
- 6 Reset the stop watch at starting point.
- 7 Start the stop watch and switch ON the UPS simultaneously, with voltmeter probes kept across the battery terminals.
- 8 Observe the readings on the meter and terminals record in Table-1.
- 9 Observe the lamp glow with beep sound carefully and stop the clock immediately when the lamp goes off.
- 10 Note down the readings on the voltmeter and stop watch in Table 1.

**Table 1**

<b>Status of UPS</b>	<b>Battery voltage</b>		<b>Full load</b>
	<b>No load</b>	<b>Light load</b>	
UPS OFF			
UPS ON			

Fig 1

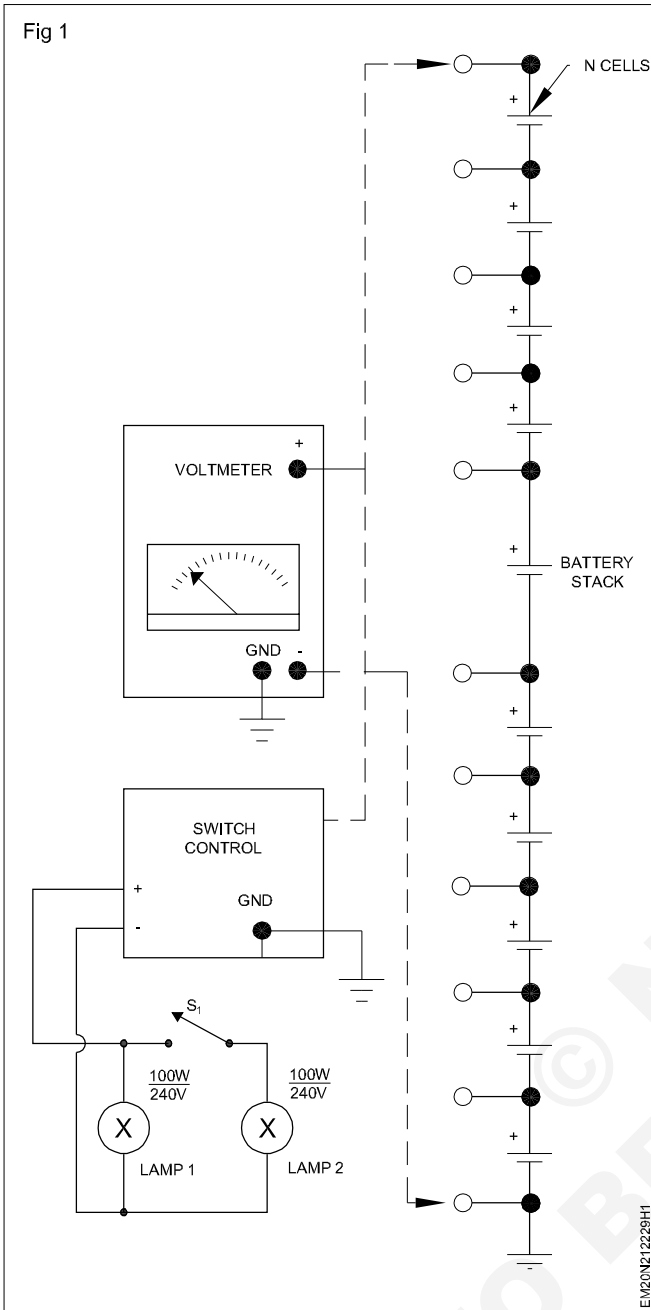

11 Get the work checked by the Instructor.

-----



**Identify and test an LED and a Photodiode to verify the photo emitting effect and light sensitivity**

**Objectives:** At the end of this exercise you shall be able to

- identify the Photodiode and LED devices in circuits.

**PROCEDURE**

**TASK 1 : Test a LED using a digital multimeter**



Testing LED lights is simple with a digital multimeter, which will give you a clear reading of how strong each light is. The brightness of the LED while you test it will also indicate its quality. A simple coin cell battery holder with leads will also let you know if your LED lights are still working.

- 1 A digital Multimeter with diode testing
- 2 LED
- 3 Basic multi-meters measure just amps, volts, and ohms. To test LED lights, select a multi-meter with a diode setting.
- 4 Connect the red and black test leads to the outlets on the front of the multimeter. The red lead is the positive charge. The black lead is the negative and should be plugged into the input labelled "COM."
- 5 Connect the black probe to the cathode and the red probe to the anode. Touch the black probe to the cathode end of the LED, which is usually the shorter prong. Next, touch the red probe to the anode, which should be the longer prong.
- 6 Be sure to connect the black probe before the red probe, as the reverse might not give you an accurate reading.

- 7 Turn the dial on the front of the multi-meter clockwise to move it away from the "off" position.
- 8 Keep turning it until dial points on the diode setting. If it is not labelled explicitly, the diode setting may be represented by the diode circuit symbol.

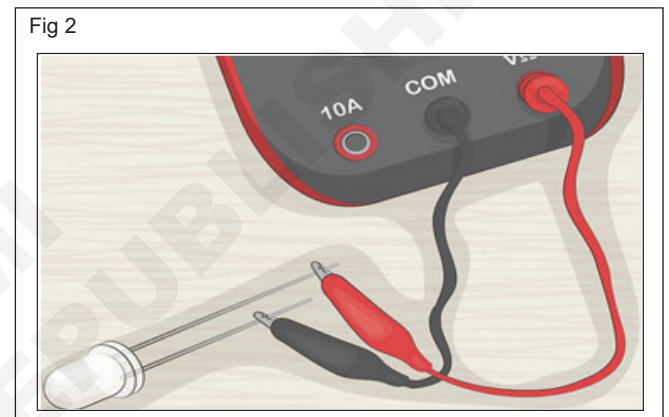

- 9 Make sure that the cathode and anode are not touching each other during this test, which may prevent the current from passing through the LED light and hinder the results.
- 10 The black and red probes should also not be touching each other during the test.
- 11 Making the connections should cause the LED to light up.
- 12 Check the value on the multimeter's digital display. When the probes are touching the cathode and anode, an undamaged Led light should display a voltage of approximately 1600 mV. If no reading appears on the screen during the test, start again to make sure the connections were made properly. If the above steps are performed properly, and still no result then that may be a sign that the LED light is not working.

**Evaluate the brightness of the LED. When the connections are proper, the LED should light up. After noting the reading on the digital screen, look at the LED itself. If it has a normal reading but looks dim, it is likely a low-quality LED. If it shines brightly, it is probably a high-efficiency LED light.**

## TASK 2 : Test a Photo Diode

- 1 A digital Multi-meter with diode testing
- 2 Photo diode

A photodiode is simply a PN silicon diode where light will generate a current proportional to light intensity on the PN junction depletion region. The photodiode is reversed biased where the Cathode goes to a positive voltage and the Anode goes to the negative side of the supply.

- 3 Connect the photodiode to the multi-meter, similar to testing a normal diode or a LED, by referring to the diagram shown.

- 4 Take precautions in connecting the probes as well as the terminals of the photodiode.
- 5 Check the value on the multimeter's digital display. When the probes are touching the cathode and anode, an undamaged photodiode should display a voltage of approximately 548 mV. If no reading appears on the screen during the test, start again to make sure the connections were made properly. If the above steps are performed properly, and still no result then that may be a sign that the photodiode is not working.

## TASK 3 : Testing LED and photodiode in combination

- 1 A digital Multi-meter or millivoltmeter
- 2 Photo diode
- 3 LED with a suitable current control resistor
- 4 6 V battery or DC power supply
- 5 Control switch
- 6 The photodiode can be tested for actual operation by arranging the light from a LED to fall on its sensing side.
- 7 Connect the LED and photodiode in a circuit as shown below.
- 8 Switch ON the circuit and verify the deflection/reading on the meter

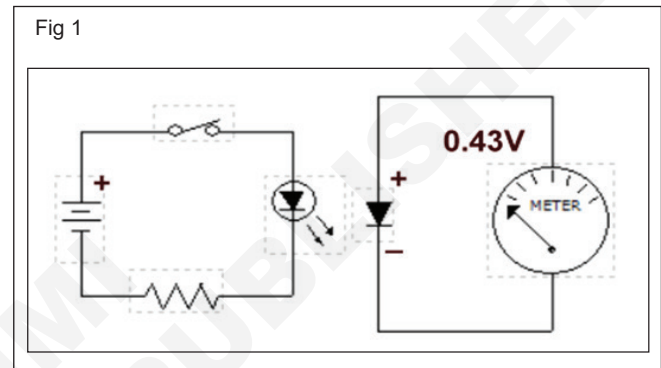

- 9 Switch OFF and verify the deflection/reading on the meter
- 10 Record your observations

**Test a Photo voltaic cell for different illumination levels and verify photovoltaic property**

**Objectives:** At the end of this exercise you shall be able to

- test the photovoltaic (PV) cell

**PROCEDURE**

**TASK 1 : Test a Photo voltaic cell**

- 1 A digital Multi-meter or millivoltmeter
- 2 A Photo voltaic cell, 3.5 W, 0.5 V, 7 A (for e.g. 4 Nos.)
- 3 5 ohm, 5 W resistor
- 4 Sunlight
- 5 Alternatively Light source with illumination control
- 6 Place solar cells in direct sunlight
- 7 Use a multi-meter that measures both Voltage and Ampere (Fig 1 & Fig 2)

- Touch the multi-meter’s black lead to the solar panel’s negative contact (which is the tab wire coming from the bottom of the solar cell).
- Touch the red lead to the solar cell’s positive contact (which is any contact point on the positive side of cell).
- The voltage reading for a 3.5 watt solar cell should be about 0.5 volts. If the reading is much less, than this solar cell is most likely defective and should not be used in making solar panel.

**Note:** In the absence of sunlight testing of solar cell using a light source inside lab can be performed to some extent though it cannot replace the sun light. The average Solar irradiation during a shade less bright day light will be more than 1000 W/m<sup>2</sup>. But the light source in lab with a lowest 230 V rated Halogen bulb will be 200 - 300 W/m<sup>2</sup>only.

**Testing For Amps**

- To test cells for the amp reading, make sure the multi-meter is shut off.
- Plug the black (-) lead into the black port and the red (+) lead into the A (amps) port.
- Turn on multi-meter.
- Set the dial of the multi-meter to the amps position.
- Put the solar cell down on a clean work area (preferably a block of wood) with the positive side facing up.
- Touch the multi-meter’s black lead to the solar panel’s negative contact
- Touch the red lead to the solar cell’s positive contact
- The current reading for a 3.5 watt solar cell should be about 7.0 amps. If the reading is much less, than this solar cell is most likely defective and should not be used in making a solar panel.
- Hence in the case of this solar cell the volt, amp and watt readings are: 0.5 volts, 7.0 amps and 3.5 watts.
- Also observe that when a solar cell is shaded, the current through the entire string is reduced.

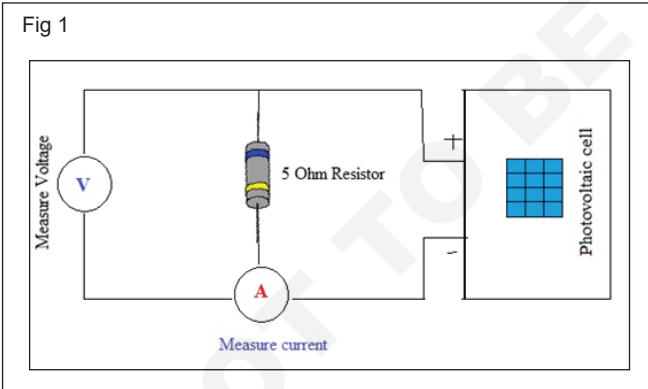

**Testing For Volts**

- Make sure the multi-meter is shut off.
- Plug the black (-) lead into the black port and the red (+) lead into the V (voltage) port.
- Turn on multi-meter.
- Set the dial of the multi-meter to the volt position.
- Put solar cell down on a clean work area (preferably a block of wood) with the positive side facing up. (i.e. the side without the tabs attached - facing up).

**In case of testing a solar module later on it would be noted that the current flowing through an entire string of cells can be heavily reduced if even just a single cell is shaded, leading to potentially significant loss of power output of the solar module.**

Similarly the current flowing through an entire string of modules can be heavily reduced if even just a single module is shaded, leading to potentially significant loss of power output of complete string.

Fig 2

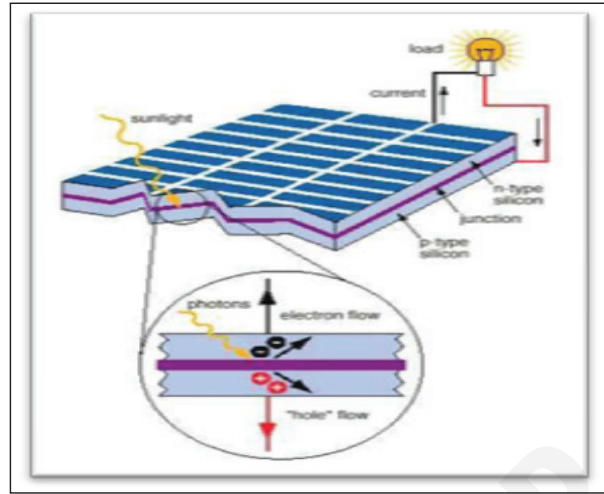

S.NO		Voltage Measured	Current measured	Conditional the PV Cell
1	Photovoltaic cell - 1			
2	Photovoltaic cell - 2			
3	Photovoltaic cell - 3			
4	Photovoltaic cell - 4			

**Plot I-V curve for photovoltaic cell based on the illumination at constant temperature**

**Objectives:** At the end of this exercise you shall be able to

- demonstrate the IV characteristics of PV cell for variation in illumination
- demonstrate the IV characteristics of PV cell for variation in load.

<b>Requirements</b>	
<b>Tools/Measurements/Equipments</b>	
<ul style="list-style-type: none"> <li>• Solar energy meter</li> </ul>	<ul style="list-style-type: none"> <li>• Solar Simulator equipments</li> </ul>

**PROCEDURE**

**TASK 1 : Understand the lab equipment Solar simulator**

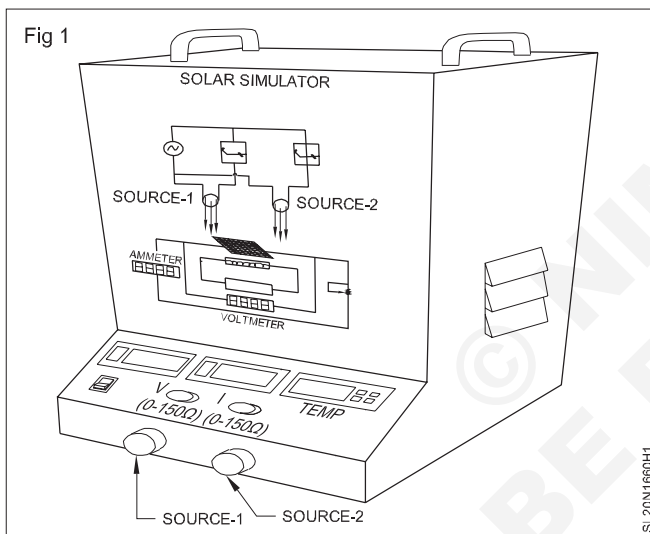

(All pictures and Circuit of Solar Simulator shown below are indicative. Actual design may vary.)

- 1 Study the lab equipment available in shop floor to learn the IV characteristics of PV cell.
- 2 Go through the manual supplied along with the equipment to know the different controls used in it and their usage
- 3 Learn the do's and don'ts

- 4 Get familiar with simulation with Solar light's properties
- 5 Remember: Technical circuit inside and its functioning not required for your study of PV cell.
- 6 Common features of this Solar Simulator should be
- 7 To simulate the sun, set of lamps are used as the source of light
- 8 To simulate the sun for its heat radiation an electrical hot plate is used
- 9 To simulate east-west movement of the sun the lamps are provided individual control
- 10 To simulate variation in solar irradiation the intensity of the lamps need to be controlled
- 11 To simulate variation in temperature the heat generated by hot plate needs to be controlled
- 12 The location of the solar PV cell is to be over the hot plate facing the lamps
- 13 A variable resistive load is required across the terminals of the solar PV cell to indicate actual load conditions
- 14 A set of digital (Preferably) voltmeter and ammeter are essential on front side
- 15 Control of intensity and heat should be independent.

**TASK 2 : Study of VI, Characteristics of Solar Cell**

- 1 Solar Simulation lab
- 2 Connect the Solar Simulator equipment to mains power supply and switch ON
- 3 Set both the intensity control rotary switch of lamps at maximum position to get the full intensity (Steps variation or continuous variation depending on the model)

- 4 Measure the intensity using Solar energy meter and record the observed value (W/m<sup>2</sup>)
- 5 Set the variable resistor load provided at high to simulate no load condition
- 6 Measure and record the voltage and current of solar cell at no load condition on display
- 7 The voltage displayed on Voltmeter is open circuit voltage (V<sub>oc</sub>)
- 8 Vary the load progressively downwards, simultaneously measure the V, I readings and record
- 9 The minimum position of load indicates the short circuit across the PV cell and hence the current will be highest. It is the short circuit current (I<sub>sc</sub>) of solar PV cell.

### Observations

Intensity of lamps (Solar irradiation) = ..... W/m<sup>2</sup>

Sl. No.	Voltmeter reading (V)	Ammeter reading (A)
1		
2		
3		
4		
5		
6		
7		
8		
9		
10		

Plot the path of curve for recorded values of V and I to get the IV curve of the solar PV cell at fixed intensity.

### Indicative plot of graph

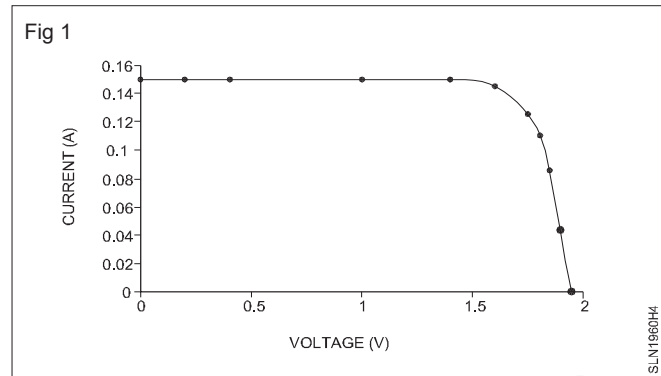

The V<sub>OC</sub> = 2 V indicates there are four numbers of PV cells are connected in series.

The I<sub>SC</sub> = 0.15 mA in this graph

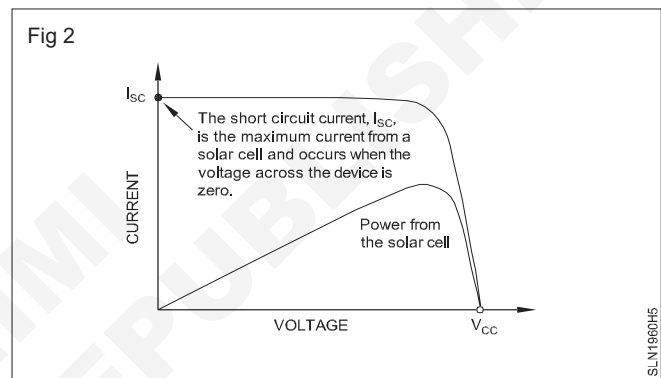

### TASK 3 : Study of V/I, Characteristics of Solar Cell with variation of light intensity and varying load conditions

#### Solar Simulator equipment

- 1 Connect the Solar Simulator equipment to mains power supply and switch ON
- 2 Set both the intensity control rotary switch of lamps at maximum position to get the full intensity (Steps variation or continuous variation depending on the model)
- 3 Measure the intensity using Solar energy meter and record the observed value (W/m<sup>2</sup>)
- 4 Set the variable resistor load provided at high to simulate no load condition
- 5 Measure and record the voltage and current of solar cell at no load condition on display
- 6 The voltage displayed on Voltmeter is open circuit voltage (V<sub>oc</sub>)
- 7 Vary the load progressively downwards, simultaneously measure the V, I readings and record the observations
- 8 The minimum position of load indicates the short circuit across the PV cell and hence the current will be highest. It is the short circuit current (I<sub>sc</sub>) of solar PV cell.
- 9 Repeat the above with reduced intensity at different levels



**Plot I-V curve for photovoltaic cell based on temperature at constant illumination**

**Objectives:** At the end of this exercise you shall be able to

- demonstrate the IV characteristics of PV cell for variation in temperature on cell.

<b>Requirements</b>
<b>Tools/Measurements/Equipments</b>
<ul style="list-style-type: none"> <li>• Solar Simulator equipment</li> <li>• Solar energy meter</li> <li>• Thermometer</li> </ul>

**PROCEDURE**

**TASK 1 : Study the IV curve for three different temperatures on solar PV cell with constant intensity**

- 1 Connect the Solar Simulator equipment to mains power supply and switch ON
  - 2 Set both the intensity control rotary switch of lamps at maximum position to get the full intensity (Steps variation or continuous variation depending on the model)
  - 3 Measure the intensity using Solar energy meter and record the observed value (W/m<sup>2</sup>)
  - 4 Measure the room temperature
  - 5 Record the observations
  - 6 Use the temperature controller and set a value little above room temperature
  - 7 Set the potentiometer to maximum to get no load condition
  - 8 Measure the voltage(V<sub>oc</sub>) and current of solar cell at no load condition on display
  - 9 Vary the potentiometer towards minimum. Measure the voltage and current (I<sub>sc</sub>) of solar cell at full load condition on display
  - 10 Record the observations
  - 11 Repeat the steps above with temperature at still higher set value. Record the observations
  - 12 Draw the graph for normal, higher and much higher temperature values and compare
  - 13 Record the observations
- Observations :** Intensity = .....W/m<sup>2</sup>

SI No	Temperature = ...°C		Temperature = ...°C		Temperature = ...°C	
	V	I	V	I	V	I



**Note: With an increase in temperature  $V_{oc}$  decreases and  $I_{sc}$  increases slightly.**

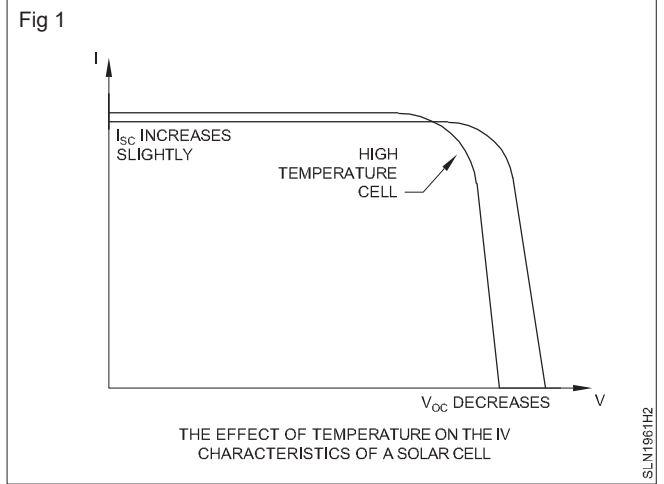

NOT TO BE REPUBLISHED

**Test photovoltaic cell in sunlight at various angles of inclination and direction**

**Objectives:** At the end of this exercise you shall be able to

- perform working with PV cell/panel in sunlight at different angles and directions.

<b>Requirements</b>	
<b>Tools/Measurements/Equipments</b>	
<ul style="list-style-type: none"> <li>• Solar PV cell</li> <li>• Voltmeter</li> <li>• Ammeter</li> </ul>	<ul style="list-style-type: none"> <li>• 5 ohm resistor</li> <li>• Magnetic compass</li> <li>• Spirit Level</li> <li>• Clinometer</li> </ul>

**PROCEDURE**

**TASK 1 : Test the Solar power generated in different directions**

**Note:**The light sensor of the Solar energy meter should face in the same direction as the Solar PV cell in each case of testing

- Connect the given components as shown in circuit

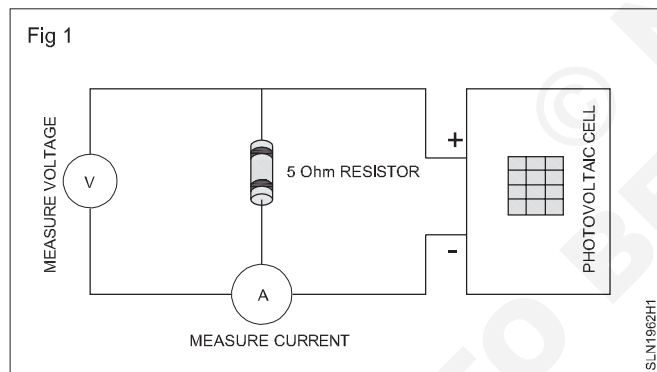

- Place the Solar PV cell in sunlight
- Locate the North pole using the Magnetic compass
- Keep the Solar PV cell facing the North pole
- Record the readings on Voltmeter and Ammeter and Solar irradiation intensity
- Rotate the facing of the Solar PV cell by 90° from North clockwise
- Record the readings on Voltmeter and Ammeter
- Continue to rotate the facing of the Solar PV cell by 90° from earlier position clockwise
- Compare the results

Position	Solar intensity	V (Volt)	A (Ampere)
N			
E			
S			
W			

**TASK 2 : Test the Solar power generated in different angle of inclinations**

**Note:**

The light sensor of the Solar energy meter should face in the same direction as the Solar PV cell in each case of testing

At any point of experiment mind that no shadow falls on the PV cell

- 1 Connect the given components as shown in circuit
- 2 Place the Solar PV cell in sunlight at flat surface; if mounted on adjustable plane allowing different inclinations more suitable otherwise manually done
- 3 Check the spirit level shows flat surface parallel to the ground. Measure the angle using clinometer and confirm it shows 0°.
- 4 Keep the Solar PV cell facing the South.
- 5 Record the readings on Voltmeter and Ammeter and Solar irradiation intensity
- 6 Lift the facing of the Solar PV cell by steps of 5° from 0°. (Steps of 2 or 3 degrees of change in angles give better results)
- 7 Record the readings on Voltmeter and Ammeter

Fig 1

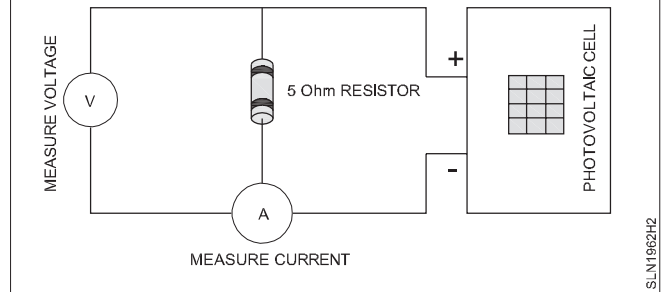

- 8 Continue to change the angle of facing of the Solar PV cell from earlier position towards south
- 9 Record the readings on Voltmeter and Ammeter
- 10 Repeat the above for some more angles
- 11 Compare the results
- 12 The angle that gives maximum Solar power is the Tilt angle for given location

Angle (°)	Solar intensity	V (Volt)	A (Ampere)
0			
5			
10			
15			
20			
25			

**Wire a solar controller to a battery storage station**

**Objective :** At the end of this exercise you shall be able to

- prepare wires for connection and wire the terminals of charge controller & batteries properly.

Requirements			
<b>Tools/ Equipments/ Instruments</b>		<b>Material/ Components</b>	
• Trainees tool kit	- 1 Set.	• Connecting wires with lug	- as reqd.
• Solar panel 12V	- 3 Nos.	• Battery 12V /10AH(minimum)	- 3 Nos.
• Solar charge controller (with operating instruction leaflet)	- 1 No.		

**PROCEDURE**

**TASK 1 : Wiring of solar charge controller to battery station**

- 1 Pick the solar charge controller available in the lab.
- 2 Select Lead-Acid or Gel-cell battery as per requirement.
- 3 Connection details of the controller as shown in Fig 1.(Refer to the instructions provided by the manufacturer)

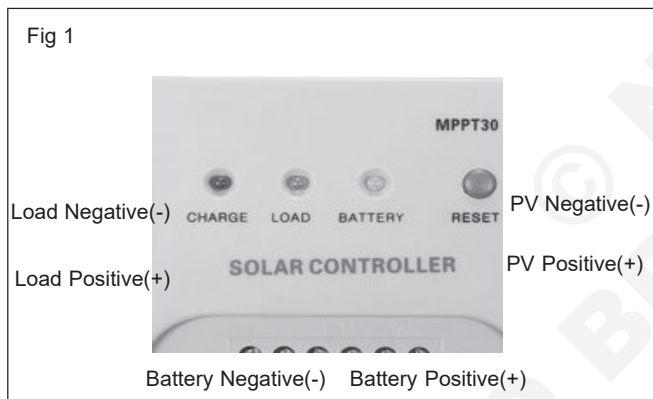

- 4 Connect the terminal marked battery negative (-) on the solar charge controller to the negative (-) of battery terminal and tighten the screw.
- 5 Install a DC Breaker or a DC fuse holder in the positive wire as shown in Fig 2.

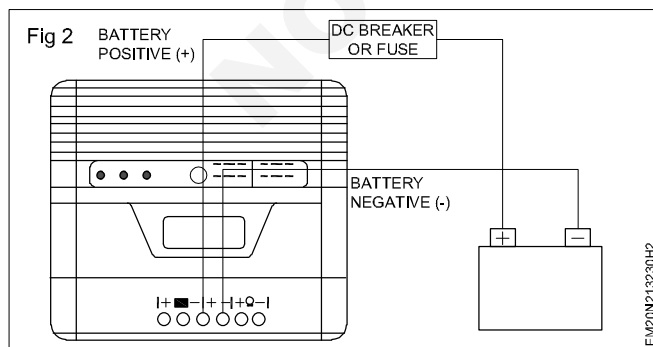

- 6 Use two battery cables. Remove insulation sleeve 12 mm and insert conductor into cable lug terminal as shown in Fig 3.

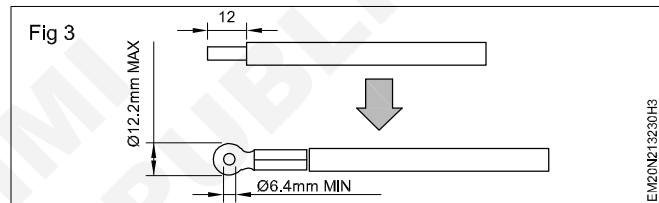

- 7 Connect the terminal marked battery positive (+) on the solar charge controller to the positive (+) battery terminal and tighten the screw.
- 8 If more voltage is required, connect the batteries, in series as shown in Fig 4.

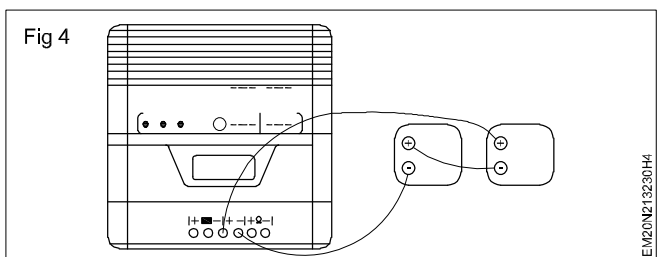

- 9 If more current is required, connect batteries in parallel as shown in Fig 5.

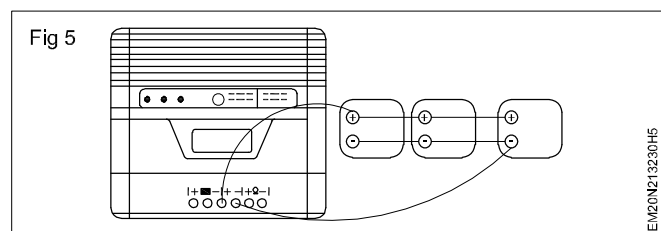

- 10 Get the work checked by the instructor.

**Connect storage batteries to a power inverter**

**Objectives:** At the end of the exercise you shall be able to

- install the storage battery and charge controller to inverter.

Requirements	
<b>Tools/Equipments/ Instruments</b>	<b>Materials/ Components</b>
<ul style="list-style-type: none"> <li>• Trainees tool kit - 1 set.</li> <li>• Solar charge controller - 1 No.</li> <li>• Solar inverter with user manual - 1 No.</li> </ul>	<ul style="list-style-type: none"> <li>• Battery 6V/10A - 1 No.</li> <li>• Fuse 1A - 1 No.</li> <li>• Circuit breaker - 1 No.</li> <li>• Connecting wires with lugs - as required</li> </ul>

**PROCEDURE**

**TASK 1 : Connection of storage battery and charge controller to inverter**

**Note:** Before connecting to PV modules, install separately a DC circuit breaker between inverter and PV modules.

- 1 Connect the battery +ve terminal to fuse holder as shown in Fig 1.

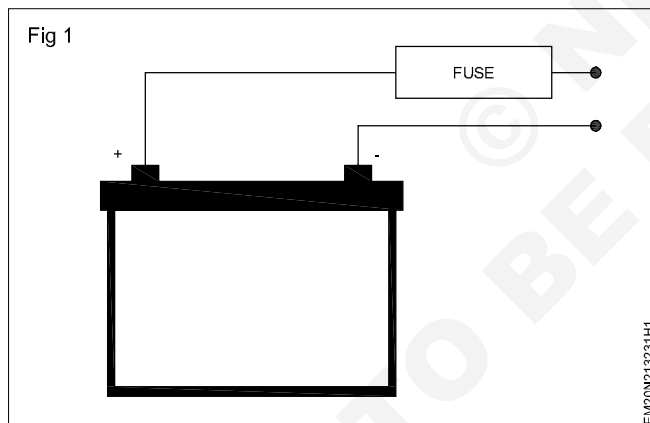

- 2 Connect the fuse holder to DC circuit breaker one end as shown in Fig 2.

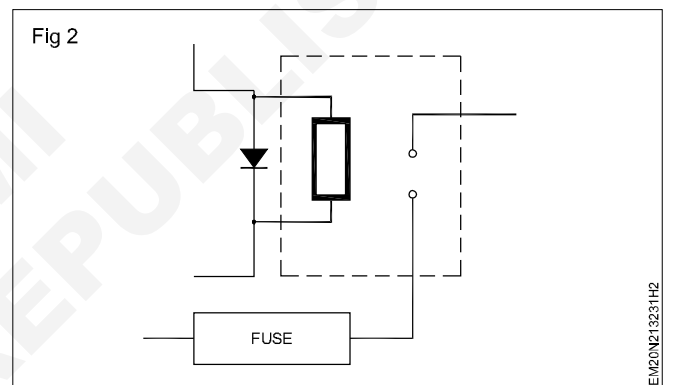

- 3 Remove wiring cover in the inverter, you will see as shown in Fig 3.

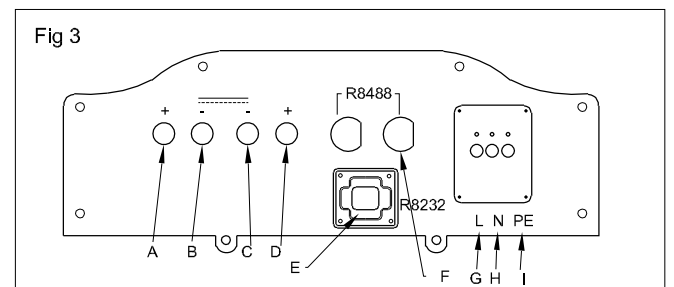

A,B,C,D	CONNECTOR FOR DC INPUT, THE POLARITY SEQUENCE IS POSITIVE,NEGATIVE,NEGATIVE,POSITIVE(+,-,-,+). PLEASE FIND LABEL WITH POLARITY MARKERS.
E	RS232 COMMUNICATION INTERFACE
F	RS485 COMMUNICATION INTERFACE
G,H,I	CONNECTOR FOR AC OUTPUT THEY ARE L,N AND PE LINES

**Attention**

- The wire connection can only be done after the inverter is fixed in proper position on the wall.
- Make sure the max. open circuit voltage and short circuit current of solar arrays are not exceeded the stipulated range of the inverter.

- Choose proper cable for power input and output lines.
- While connecting the inverter, make sure no connection among AC, DC and any power resources are disconnected.
- Identify the polarity of wires and connection ports first, then connect the inverter with solar arrays in proper polarity.

- 4 Check the nominal voltage of batteries.
- 5 Use two battery cables. Remove insulation sleeve 12 mm and insert conductor into cable lug terminals, as shown in Fig 4 and fix it on both cables.

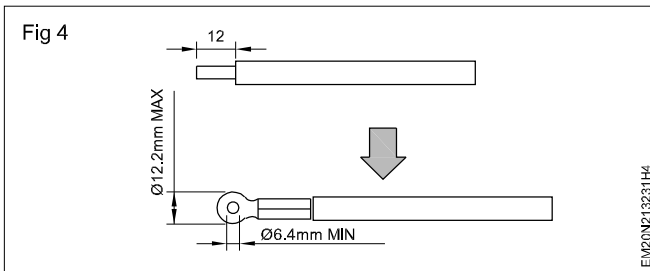

- 6 Connect the terminal marked battery negative (-) on the Solar inverter to the negative (-) battery terminal and tighten the screw.
- 7 Connect the DC breaker one end to solar inverter (+) terminal and tighten the screw as shown in Fig 5.

- 8 Make sure the wires are securely connected.
- 9 Get the work checked by the instructor.

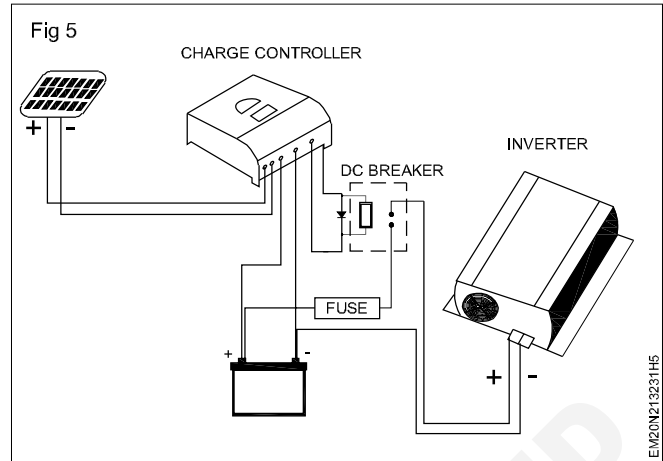

**Connect and test solar panel to the inverter and run the load**

**Objectives:** At the end of the exercise you shall be able to

- connect and test solar panel to the inverter
- test the solar panel (A) Open circuit test (B) short circuit test (C) Run the AC load (D) Run the DC load.

Requirements	
<b>Tools/ Equipments/ Instruments</b>	<b>Materials/ Components</b>
<ul style="list-style-type: none"> <li>• Trainees tool kit - 1 Set.</li> <li>• Solar charge controller - 1 No.</li> <li>• Solar inverter with user manual - 1 No.</li> <li>• DC load - 1 No.</li> <li>• Solar panel - 1 Set.</li> <li>• Digital multimeter with probes - 1 No.</li> <li>• AC load - 1 No.</li> </ul>	<ul style="list-style-type: none"> <li>• Battery 6V/10A - 1 No.</li> <li>• Fuse 1A - 1 No.</li> <li>• Circuit breaker - 1 No.</li> <li>• Connecting wires with lugs - as reqd.</li> <li>• Solar panel 12V with manual - 1 No.</li> </ul>

**PROCEDURE**

**TASK 1 : Connect solar panel to the inverter**

- 1 Before connecting to PV modules, please install separately a DC circuit breaker between inverter and PV modules.
- 2 Connect the battery +ve terminal to fuse holder as shown in Fig 1.

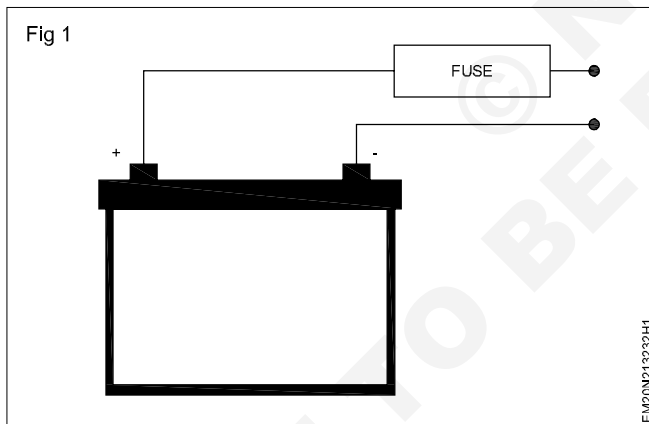

- 3 Connect the fuse holder to DC circuit breaker one end as shown in Fig 2.
- 4 Remove wiring cover in the inverter ,you will see as shown in Fig 3.

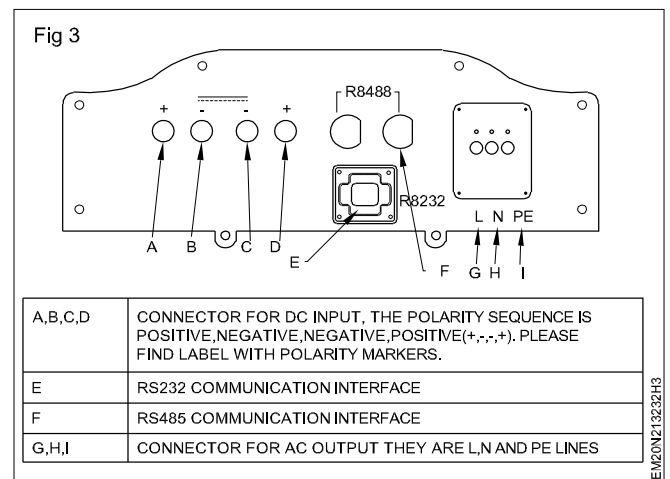
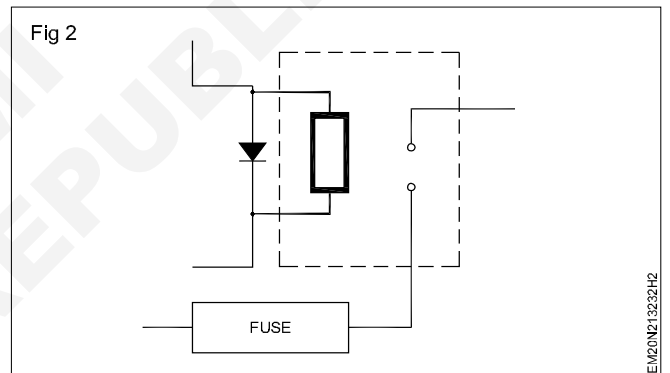

**Attention**

- The wire connection can only be done after the inverter is fixed in proper position on the wall.
- Make sure the max. open circuit voltage and short circuit current of solar arrays are not exceeded the stipulated range of the inverter.
- Choose proper cable for power input and output lines.

- While connecting the inverter, make sure no connection among AC, DC and any power resources are disconnected.
- Identify the polarity of wires and connection ports first, then connect the inverter with solar arrays in proper polarity.

- Check the nominal voltage of batteries.
- Use two battery cables. Remove insulation sleeve 12 mm and insert conductor into cable lug terminals, as shown in Fig 4 and fix it on both cables.

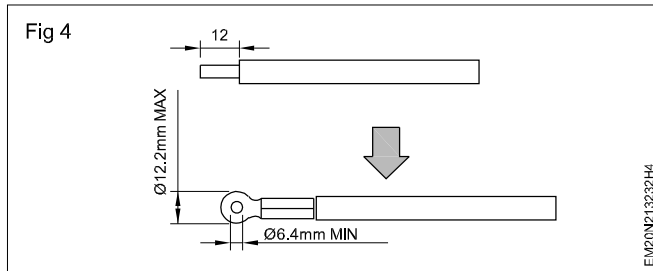

- Connect the terminal marked battery negative (-) on the Solar inverter to the negative (-) battery terminal and tighten the screw.
- Connect the DC breaker one end to solar inverter (+) terminal and tighten the screw as shown in Fig 5.

- Make sure the wires are securely connected.
- Get the work checked by the instructor.

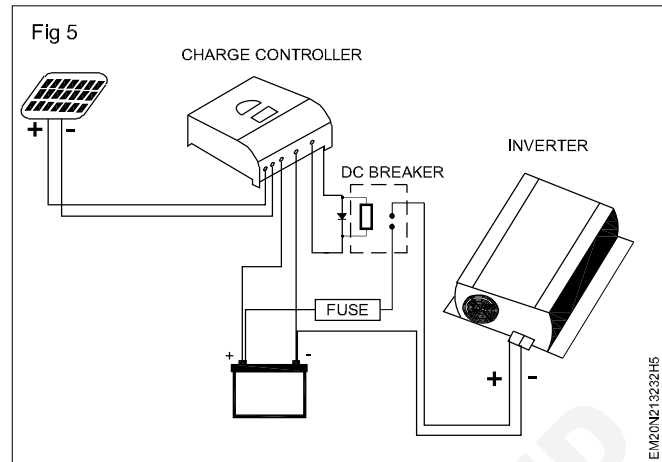

## TASK 2 : Test the solar panel

### Caution

Observe polarities when connecting solar panels and batteries.

Photovoltaic panels produce electricity when exposed to light, so it is recommended to cover the front of the solar panel at outdoors to help avoid shocks. This is particularly important for higher voltage panels.

### A) Open circuit test

- Disconnect the solar panel completely from the battery and regulator.
- Change position of the solar panel towards the sun or any light source.
- Set the DMM to measure DC voltage at 20V range.
- Connect the multimeter probes to the SPV panel by observing the correct polarity as shown in Fig 1.
- Measure the open circuit SPV voltage.

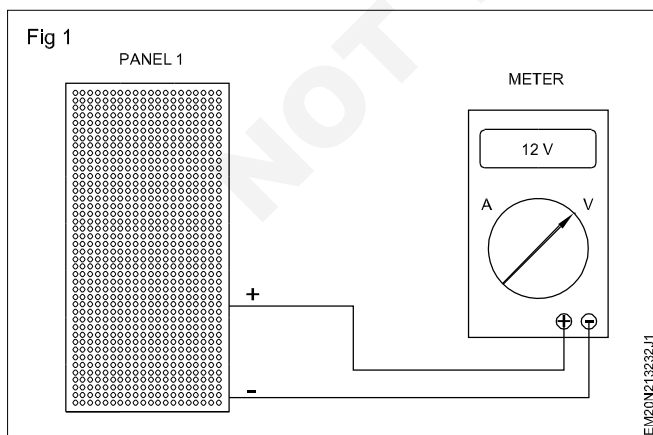

### B) Short circuit test

- Disconnect the solar panel completely from the battery and regulator.
- Change position of the solar panel towards the sun or light source.
- Ensure that the multimeter is set at 10A, at least to start with. If needed change the setting later.
- Measure the current by connecting +ve lead on the multimeter to the +ve on the panel and the -ve from the multimeter to the -ve on the panel and record the readings in TABLE 1.
- Calculate the maximum voltage that can be dissipated by the SPV panel using the formula.  

$$P = V \times I \text{ watts}$$
- Get the work checked by the instructor.

TABLE 1

Solar panel voltage and current	
Voltage	: _____ (V)
Current	: _____ (A)
Power	: _____ (W)



### C) Run the AC load

- 1 Remove wiring cover in the inverter as shown in Fig 1.

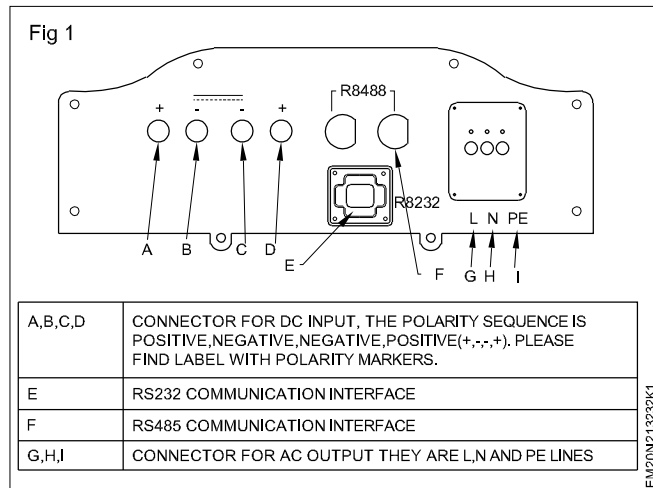

- 2 Connect the AC output socket to circuit breaker as shown in Fig 2.

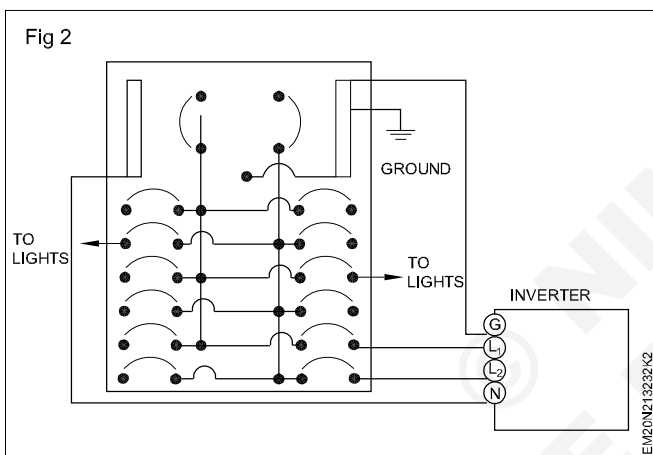

- 3 Connect the circuit breaker to the load as shown in Fig 3.

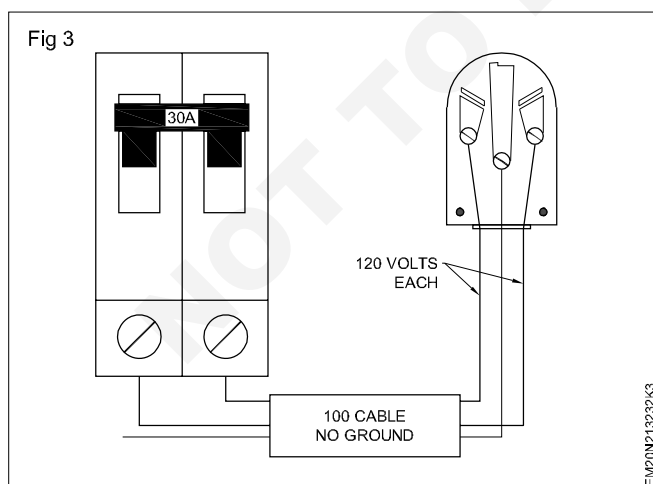

- 4 Get the work checked by the instructor.

### D) Run the DC load

- 1 Carryout the steps 1 to 5 from exercise 2.13.230
- 2 Follow the connection details of the controller as shown in Fig 1.

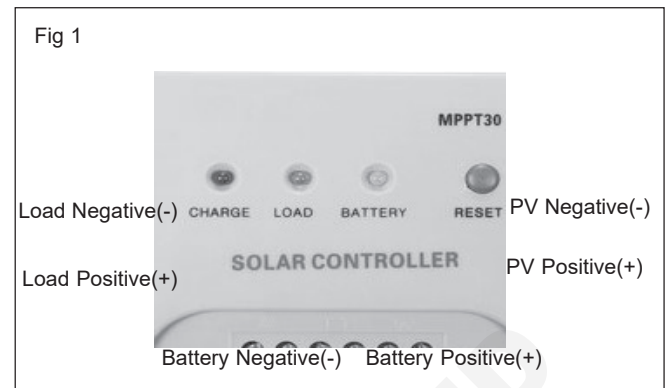

- 3 Connect the terminal marked load negative (-) on the solar charge controller to the negative (-) load terminal and tighten the screw.
- 4 Connect the terminal marked load positive (+) on the solar charge controller to the positive (+) battery terminal and tighten the screw as shown in Fig 2.

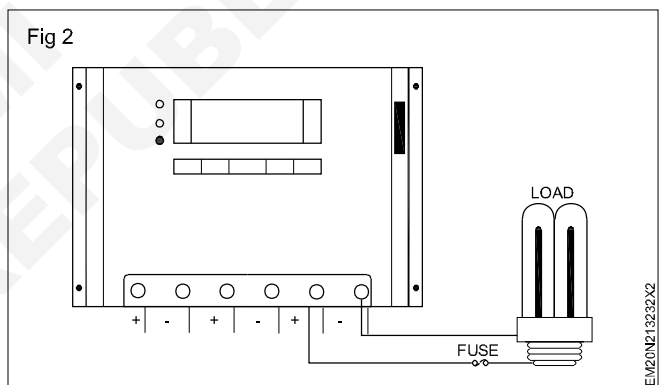

- 5 Switch ON the charge controller and observe the bulb. The bulb should be illuminated.
- 6 Get the work checked by the instructor.

**Install a solar power panel to charge a rechargeable 12V DC battery and find out the charging time**

**Objectives:** At the end of the exercise you shall be able to

- install a solar power panel for 12V DC application
- assemble an application circuit for 12V DC application.

Requirements	
<b>Tools / Equipments/ Instruments</b>	
• Trainees tool kit	- 2 Nos
• Digital multimeter with probes	- 1 No.
• Solar charge controller trainer with manual	- 1 No.
• Solar battery 12V DC/ 100 AH	- 1 No.
<b>Materials/ Components</b>	
• Wires with lugs and patch cords	- 1 Set.
• Insulation tape	- 1 No.

**PROCEDURE**

**Note: Before connecting to PV modules, please install separately a DC circuit breaker between inverter and PV modules.**

- 1 Connect the battery +ve terminal to fuse holder as shown in Fig 1.

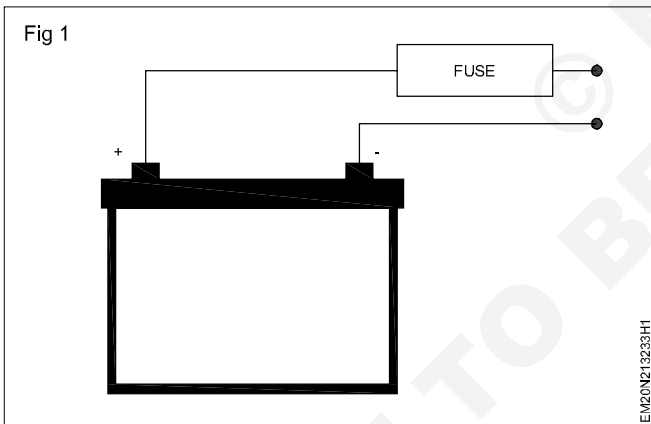

- 2 Connect the fuse holder to DC circuit breaker as shown in Fig 2.

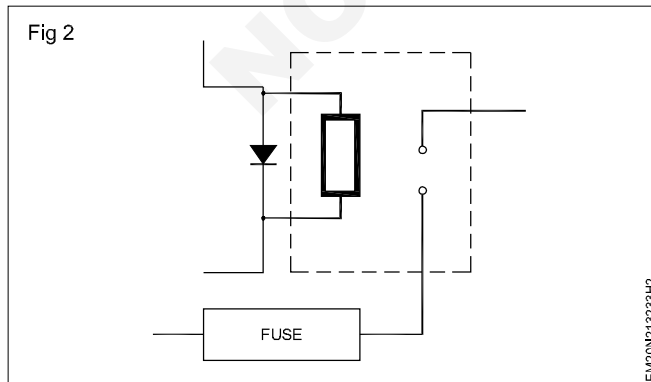

- 3 Check the nominal voltage of batteries.

- 4 Use two battery cables. Remove insulation sleeve 12mm and insert conductor into cable lug terminals, as shown in Fig 3 and fix it on both cables.

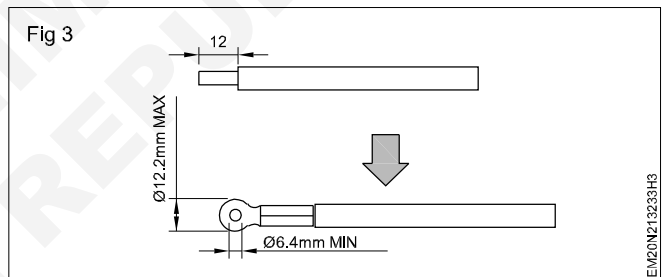

- 5 Connect the terminal marked battery negative (-) on the solar inverter to the negative (-) battery terminal and tighten the screw.
- 6 Connect the DC breaker one end to solar inverter (+) terminal and tighten the screw as shown in Fig 4.
- 7 Make sure the wires are securely connected.

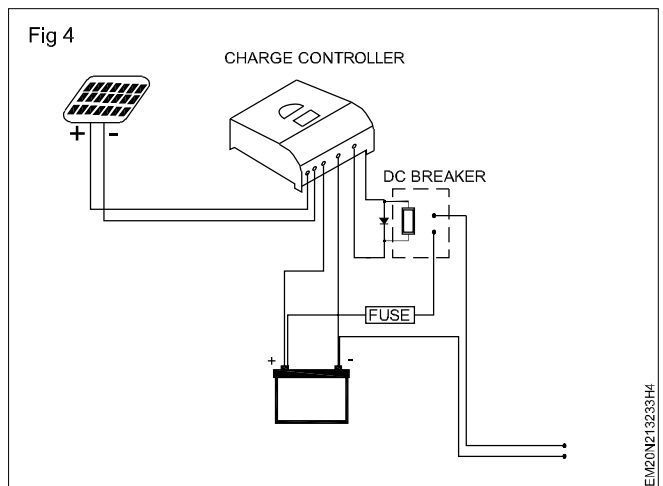

- 8 Get the work checked by the instructor.

**Install a solar inverter**

**Objectives :** At the end of this exercise you shall be able to

- install the solar inverter
- connect the solar inverter to grid(AC).

Requirements	
<p><b>Tools/ Equipments/ Instruments</b></p> <ul style="list-style-type: none"> <li>• Trainees tool kit - 1 Set.</li> <li>• Electric drilling machine with drill bit - 1 Set.</li> <li>• Solar inverter with user manual - 1 No.</li> <li>• Digital multimeter with probes - 1 No.</li> </ul>	<p><b>Materials/ Components</b></p> <ul style="list-style-type: none"> <li>• Ruler or measuring tape - 1 No.</li> <li>• Pencil - 1 No.</li> <li>• Connecting wires - as reqd.</li> <li>• User manual of given solar inverter - 1 Set.</li> </ul>

**PROCEDURE**

**TASK 1 : Install the solar inverter**

**Planning the installation:** (Fig 1)

- 1 Choose your installation location carefully.
- 2 Check that the wall is capable of bearing the heavy load of the device and vibration-free to avoid disruptive vibrations.
- 3 Lift and move the solar inverter with the help of atleast two to three people.
- 4 Select correct size of dowels and screws that are suitable for the wall material and the heavy weight.

- 6 Drill four holes in the marked location with four screws as shown in Fig 2.

**Do not mount the inverter on flammable construction materials.**

**Always use the mounting plate supplied with the solar inverter.**

**This inverter can make noises during operation which may be perceived as a nuisance in a living area.**

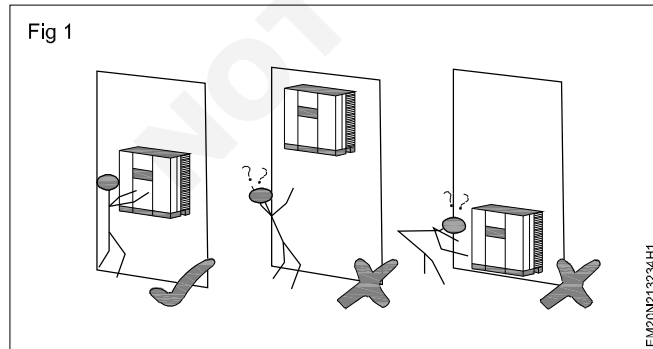
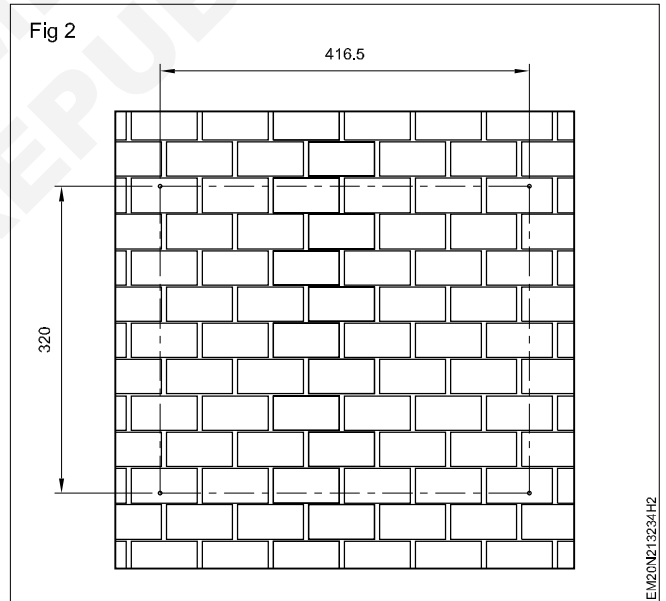

- 5 Measure the dimension of the solar inverter and mark the hole in wall.

- 7 Place the unit on the surface and align the mounting holes with the four screws as shown in Fig 3 and mount the solar inverter.

- 8 Check if the solar inverter is firmly secured as shown in Fig 4.

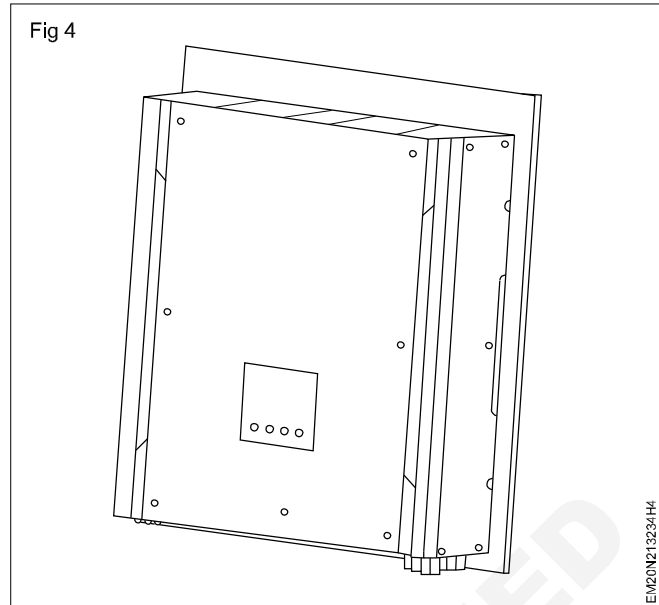
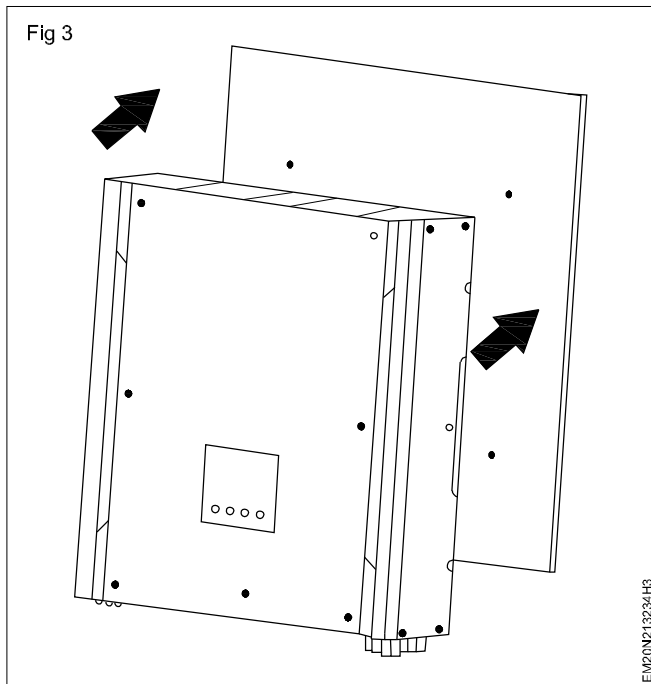

## TASK 2 : Connecting the solar inverter to the grid (AC)

- 1 Read label and note down rated voltage and current of the given solar inverter.
- 2 Check the grid voltage and frequency with DMM it should be the same to "VAC" value on the product label.
- 3 Turn off the circuit breaker.
- 4 Remove the insulation sleeve 8 mm for three conductors, and shorten the phase L and neutral conductor N 3 mm as shown in Fig 1.
- 6 Make sure the wires are securely connected. the reference tightening torque is 0.82N.M

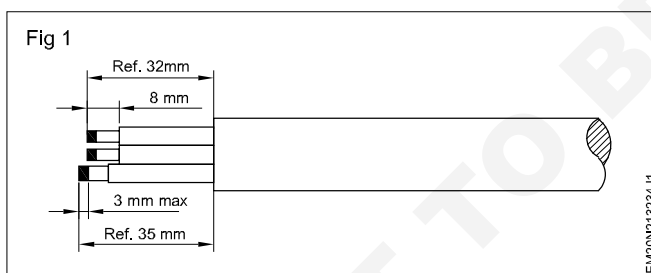

- 5 Connect wires according to polarities indicated on terminal block, be sure to connect PE protective earth conductor  first.

L - LINE ( brown or black ) next

 - ground (yellow - green) and

N - Neutral (blue)

**Its only allowed to connect load to "AC output connector". Do NOT connect the utility to "AC output connector".**

**Be sure to connect L terminal of load to L terminal of "AC output connector" and N terminal of load to N terminal of "AC output connector". The G terminal of "AC output connector" is connected to grounding of the load. Do NOT interchange the wires.**

**This inverter is not allowed to operate in parallel. Please do NOT parallel connect more than one unit in AC output connector. Otherwise, it will damage this inverter.**

- 7 Get the work checked by the instructor.

**Dismantle, Identify the parts and assemble different types of smart phones**

**Objectives :** At the end of this exercise you shall be able to

- **dismantle the given cell phone/smart phone**
- **identify and list the different sections/parts of the cell phone/smart phone**
- **assemble the given cell phone/smart phone.**

**Requirements**

**Tools/Equipments/Instruments**

- Cell phone/ Smart phone - 1 No.
- Precision screw driver set - 1 Set.
- Trainees tool kit - 1 Set.
- Digital multimeter with probes - 1 No.
- User manual - as reqd.

**Materials/ Components**

- Nil

**PROCEDURE**

**TASK 1 : Dismantling the cell phone / smart phone**

- 1 Switch OFF the cell phone/smart phone and locate small hole next to headphone jack. Push the tip of a needle or paperclip into hole to eject sim tray. (Fig 1)

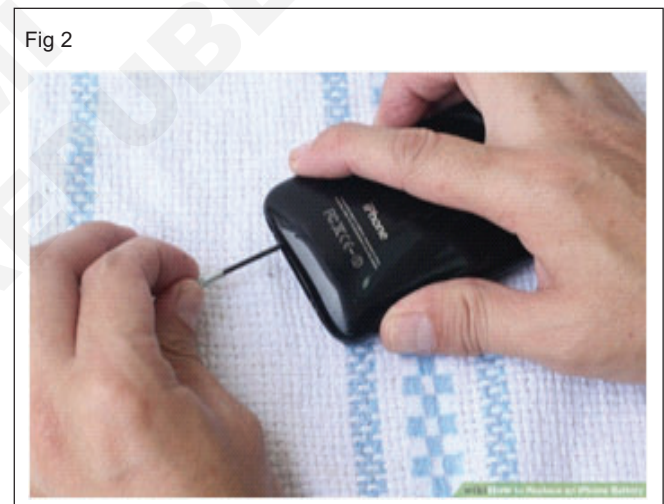

- 2 Hold your device on end to locate two small screws on either side of the back cover. Remove the screws using a small star screwdriver. (Fig 2)
- 3 Insert a spudger between the chrome ring and front panel glass directly above one of the screw holes. Try gently to separate the display from the back panel. (Fig 3)
- 4 Lift the panel up from the back cover end be careful not to tear or break any ribbons connected near the other end.(Fig 4)
- 5 Continue to hold the display panel with one hand, and use your other hand and a spudger to disconnect the black ribbon cable labeled "1".(Fig 5)



Fig 4



Fig 7



Fig 5



Fig 8



6 Rotate the display assembly up until it is roughly vertical. This will allow easier access for removing the remaining cables. (Fig 6)

9 Slide the black ribbon cable out of its connector, and remove the display assembly from the cell phone. (Fig 9)

Fig 6

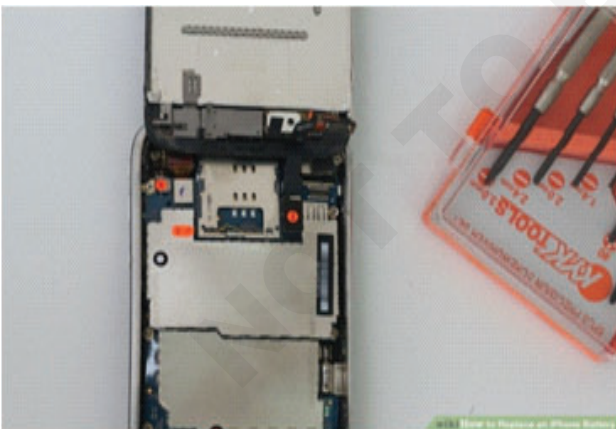

Fig 9



7 Use a spudger to disconnect the black ribbon cable labeled "2." (Fig 7)

10 **Remove the screws surrounding the motherboard:**

8 Use a spudger to flip up the white plastic tab holding the remaining ribbon cable in place. The white tab will rotate up 90 degrees, releasing the ribbon cable. (Fig 8)

Remove the screws 2-3 mm star screws with partial threads securing the logic board to the rear panel. (Fig 10)

11 Remove the screws using 2-3 mm star screws with full threads securing the logic board and camera. (Fig 11)

Fig 10

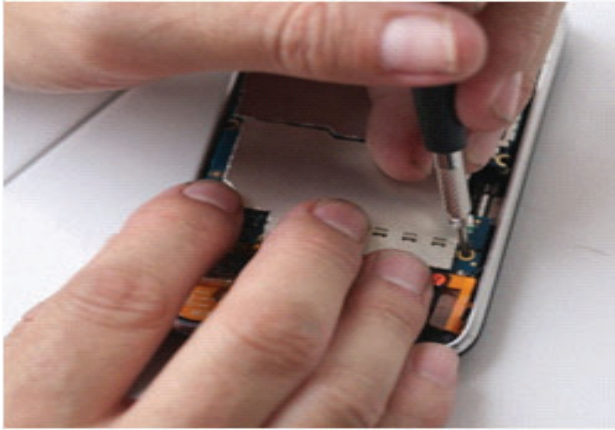

Fig 13

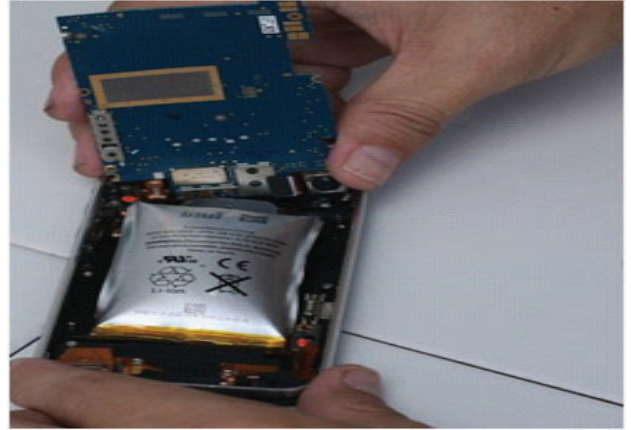

Fig 11

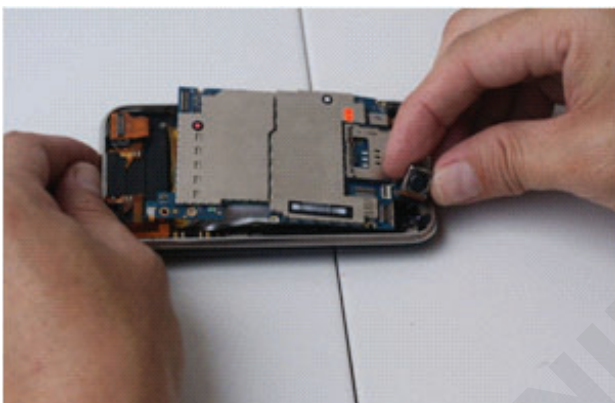

Fig 14



12 Remove the screws using 2-3 mm star screw from beneath the "Do not remove" sticker. (Fig 12)

Fig 12



Fig 15



13 Unplug ribbon, which is connected to display and other parts. (Fig 13)

14 Unplug this connecting ribbon and place the mother board aside. (Fig 14)

15 Use a spudger to gently pull the camera up and out of its housing in the rear panel. The camera cannot be removed entirely yet because it's connected to the bottom of the logic board. (Fig 15)

16 Use a spudger to gently try up the end of the logic board closest to the dock connector. If the board won't lift up, double check to make sure all the screws securing the logic board have been removed. (Fig 16)

17 Slide the logic board towards the back side connector and out of the cell phone. (Fig 17)

18 Use a little force, pull up and remove the attached tab on the battery. (Fig 18)

19 Replace battery and repeat steps in reverse to reassemble! (Fig 19)

20 Dismantling of the cell phone has been completed.

21 Get the work checked by the Instructor.

Fig 16

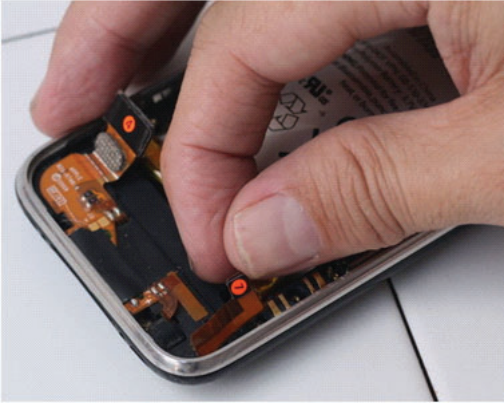

Fig 18



Fig 17

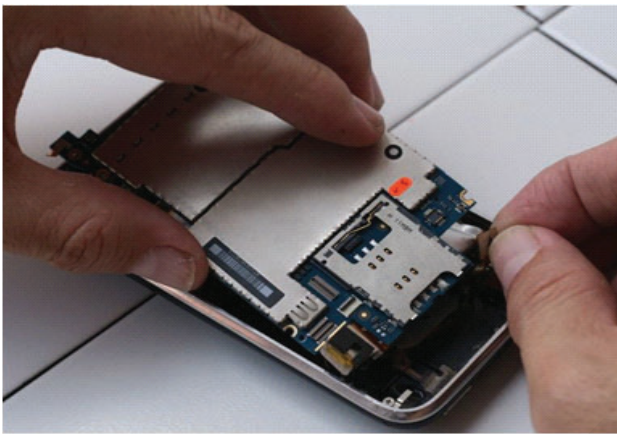
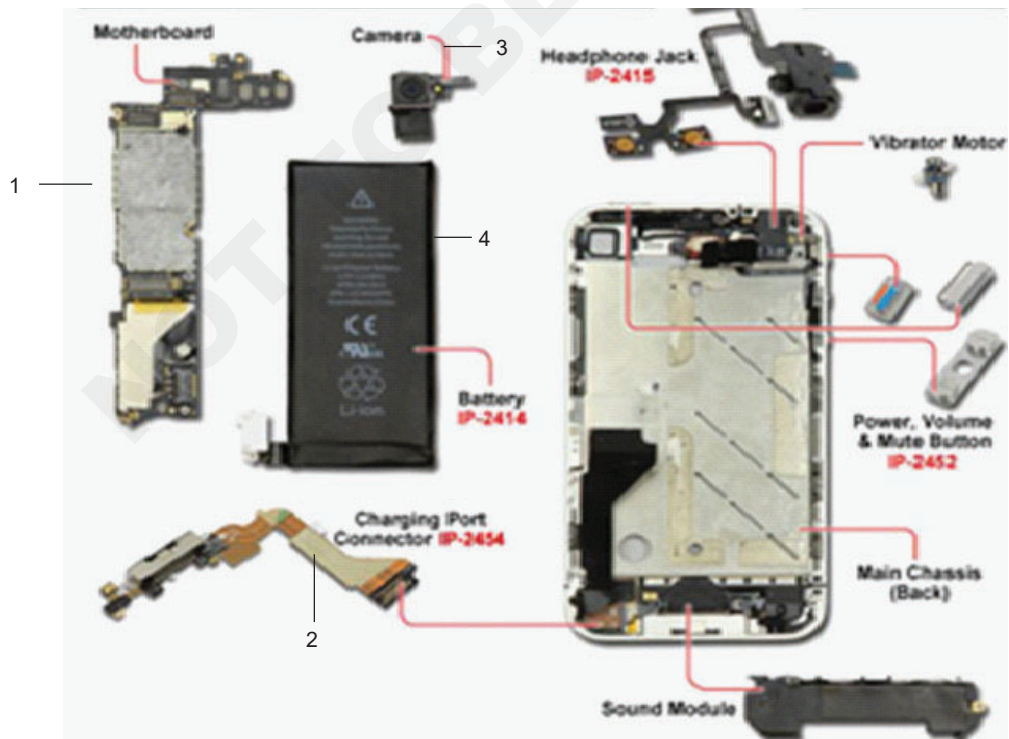

Fig 19



**TASK 2 : Identification and list the different sections of the cell phone/smart phone**

Fig 1





- 1 Identify the parts of a cell phone given in Fig 1 and record names of each part in the Table 1.
- 2 Follow the step by step procedure done in TASK 1 in the reverse order to re-assemble the cell phone/smart phone.
- 3 Observe correct position and insert the ribbon cable/connector,etc. carefully. [They are very delicate and will get damaged easily.]
- 4 Ensure that the assembling is done correctly and all the boards are fixed in their respective positions.
- 5 Switch on the cell phone and check the working condition.

**Table 1**

SI. No.	Type of phone / smartphone	Section/Part

- 6 Get the work checked by the Instructor.

**TASK 3 : Assembling the cell phone**

- 1 Identify the parts of a cell phone given in (Fig 1) and record names of each part in the Table 1
- 2 Follow the step by step procedure done in Task 1 in the reverse order to re-assemble the cell phone.
- 3 Observe correct position and insert the ribbon cable/connector, etc. carefully (They are very delicate and will get damaged easily)
- 4 Ensure that the assembling is done correctly and all the boards are fixed in their respective positions.
- 5 Switch on the cell phone and check the working condition.

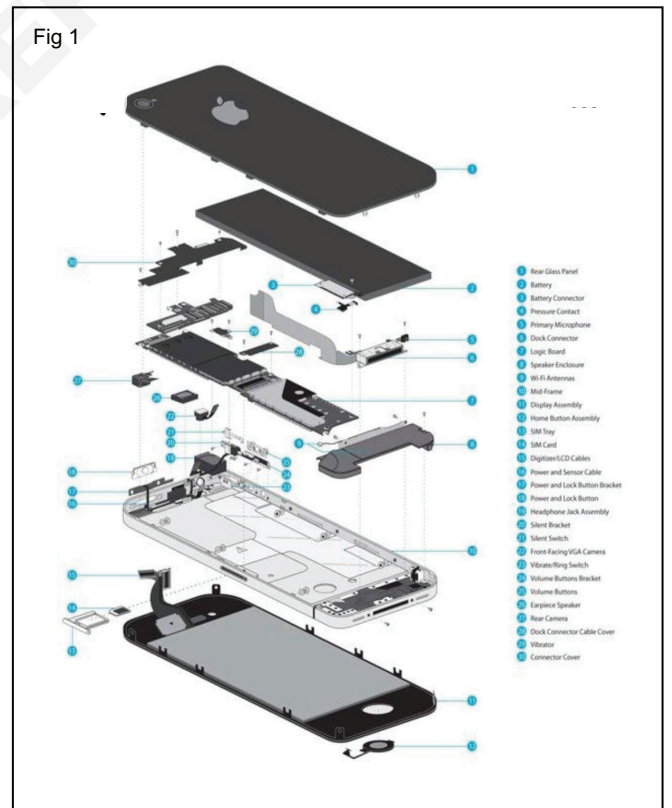

**Dismantle the cell phone / smart phone remove the keypad and clean it , test the continuity of the matrix/tracks**

- Objectives :** At the end of this exercise you shall be able to
- **remove key pad of the cell phone and clean it**
  - **replace the display and keypad of the given cell phone**
  - **remove touch screen of the smart phone and clean it.**

<b>Requirements</b>	
<b>Tools/Equipment/Instruments</b>	<b>Materials/ Components</b>
<ul style="list-style-type: none"><li>• Cell phone/ Smart phone - 1 No.</li><li>• Precision screw driver set - 1 Set.</li><li>• Tweezers with antistatic wrist strap and hand gloves</li><li>• Digital multimeter with probes - 1 No.</li></ul>	<ul style="list-style-type: none"><li>• Cotton cloth - as reqd.</li><li>• CTC/IPA Solution - as reqd.</li><li>• User manual - as reqd.</li></ul>

**PROCEDURE**

**TASK 1 : Remove the keypad and clean it**

- 1 Dismantle the cell phone by referring the previous exercise (2.14.235).
- 2 Make a mixer of half rubbing alcohol and half distilled water.
- 3 Wipe the phones keypad with a soft cloth and remove dust.
- 4 Allow the cell phone to dry before reinserting the battery or putting it back in its case.
- 5 Check the continuity of row and column pins using DMM.
- 6 Place the key pad in the right position while closing the front cover for the reassembly. Do not assemble the phone of display has to be replaced.
- 7 Switch ON the phone and check the working condition.

**TASK 2 : Replace the display**

- 1 Dismantle the cell phone by referring the previous exercise.
- 2 Remove the display by removing the small star head screw and lift the LCD display out of the cell phone.
- 3 Install the new display into your cell phone and follow the procedure in reverse order.
- 4 Insert the battery and battery cover. Switch ON the phone and check for its working.

**TASK 3 : Removing and cleaning the touch screen**

- 1 Turn the device off.
- 2 Cover the whole screen with some clear packaging tape.
- 3 Remove the back cover.
- 4 Use the painter's tape to take out flecks of glass.
- 3 Gently lift the edges of the glass off.
- 4 Work your way downward.
- 5 Remove the touch buttons carefully.
- 6 Remove the glass.
- 7 Take out the metal earpiece from the old glass.

**Removing the broken glass panel**

- 1 Heat the glue holding the glass in place.

### Applying the new glass panel

- 1 Wipe away the remaining glue on the edges of the front of the phone.
- 2 Apply double-sided tape to the top and bottom of the front panel.
- 3 Wipe the display with a lens cleaner.
- 4 Remove the protective cover from your replacement glass carefully.
- 5 Put the touch buttons back in place.
- 6 Connect the metal earpiece to the new glass.
- 7 Apply the replacement glass onto your phone.
- 8 Heat the panel again.
- 9 Get the work checked by the instructor.

-----

© NIMI  
NOT TO BE REPUBLISHED

**Interface the cell phone/smart phone to PC and transfer the data card**

**Objectives :** At the end of this exercise you shall be able to

- transfer data from phone memory to SD card
- transfer data from phone to PC.

Requirements			
Tools/Equipments/Instruments		Materials/ Components	
• Cell phone/ Smart phone with SD card	- 1 No.	• USB cable	- 1 No.
• Personal computer	- 1 No.	• User manual	- as reqd

**PROCEDURE**

**TASK 1 : Transfer app from phone memory to SD card**

1 Select the setting tab on screen. (Fig 1 & 2)

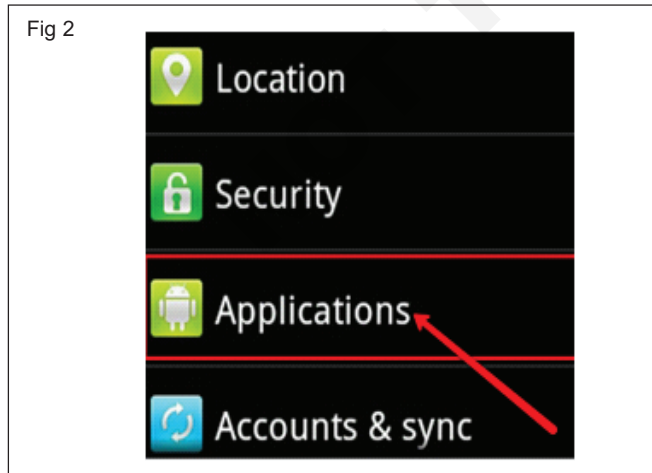
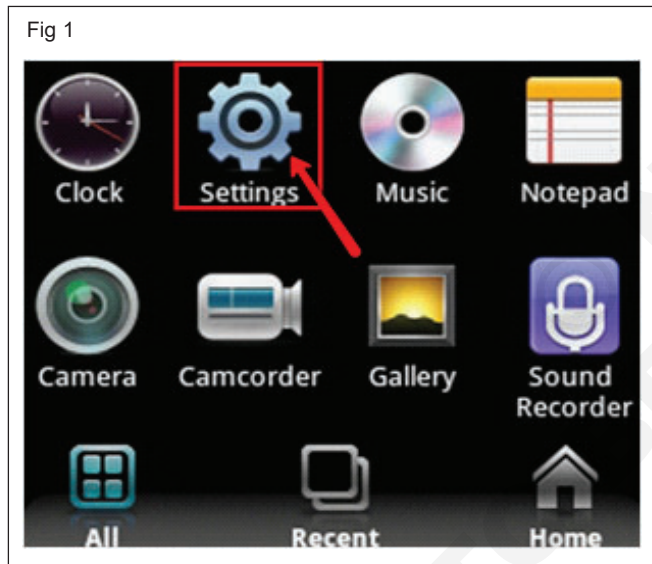

Setting can access from tab scrolling also.

2 Scroll the settings menu and select manage application tab -> Settings. (Fig 3)

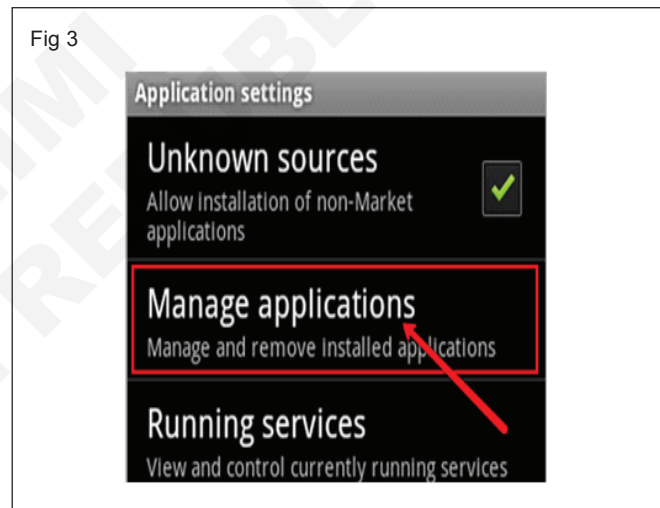

3 Now select app needed to move from phone to SD memory card.

4 Now select move to SD card option tab.(Fig 4)

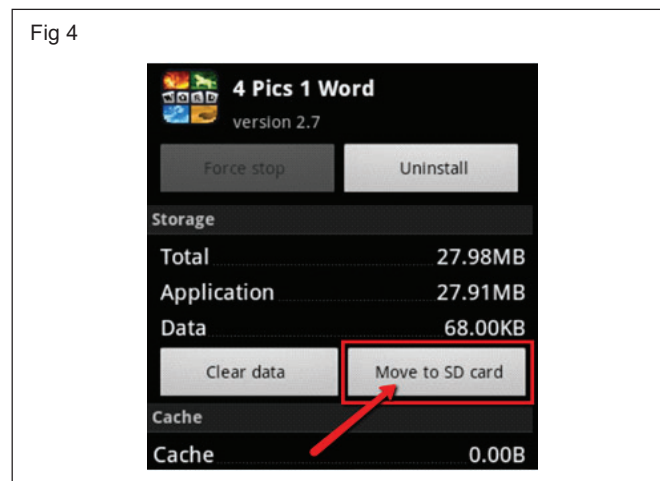

- 5 Press tab and select OK button on warning menu.
- 6 Now observe tab changing move to phone.

**Same can repeat for moving, app from memory to phone.**

**TASK 2 : Moving data (Files and Folder) from phone to SD memory card and vice versa**

- 1 Go to the home screen.
- 2 Then select the File manager and then tap on local.
- 3 Choose the external SD folder.
- 4 Tap on the folder or file to which you want to move to the SD card.
- 5 Copy the folder or file to the external SD folder by clicking on paste option.
- 6 Tap on the STORAGE on setting menu scroll the screen for SD card.
- 7 Check the file/folder is copied into SD card.

**TASK 3 : Transfer data from phone to PC using data card / USB port**

- 1 Use a data cable to connect your phone to your computer's USB port. (Fig 1)

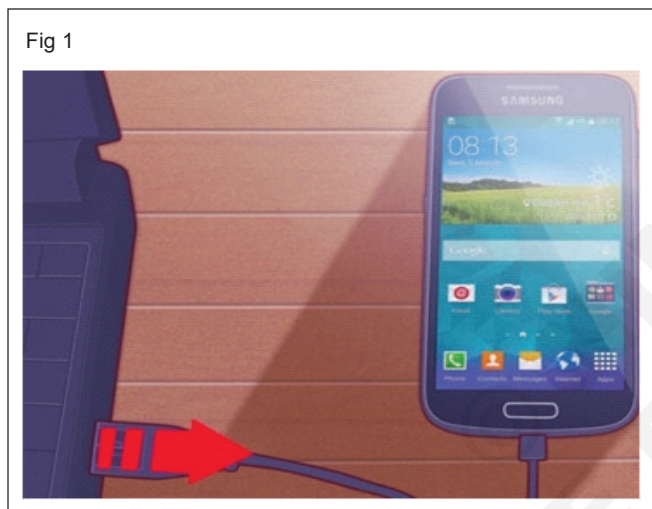

- 2 Make sure your memory card is in your phone. (Fig 2)



- 3 Touch the USB Connected notification on your phone's screen. (Fig 3)
- 4 Turn on USB storage in some model the screen as shown in Fig 9 will appear and select the option as per require menu in the PC. (Fig 4)

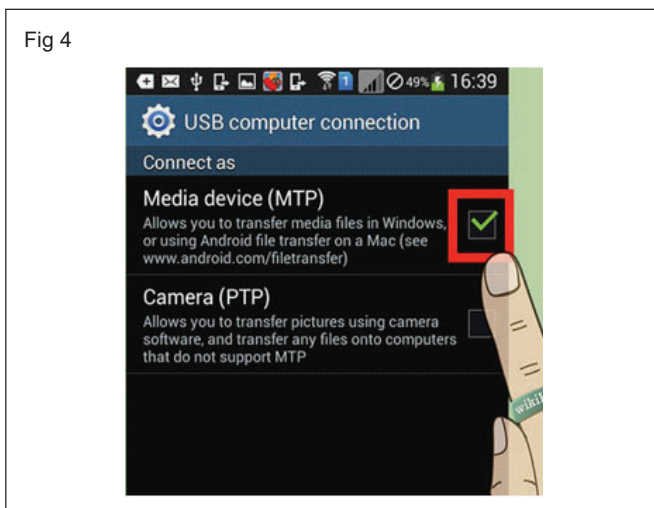
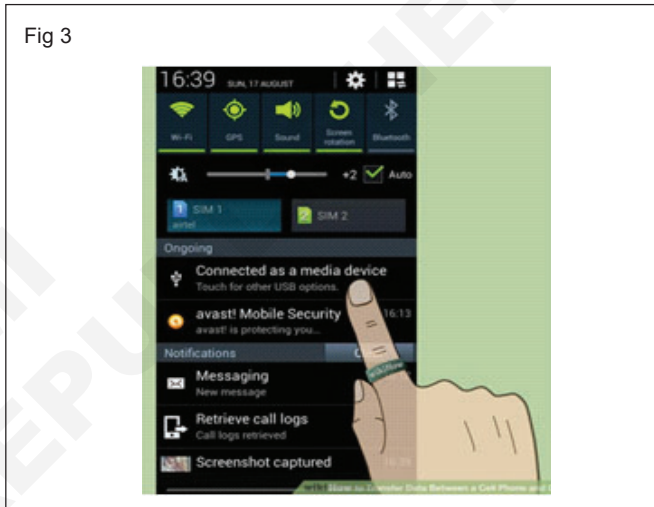

- 5 Click on My Computer and find removable storage. (Fig 5)
- 6 Drag and drop the files you want from your phone to your computer. (Fig 6)
- 7 If the files are transferred go to Notifications and select Turn Off USB Storage.
- 8 Disconnect the data cable from your phone and your computer.

Fig 5

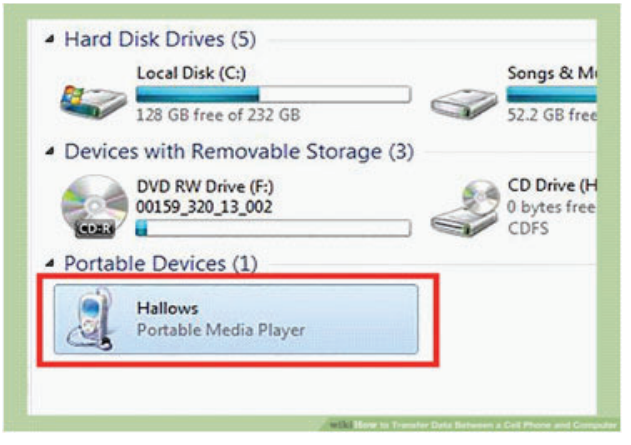
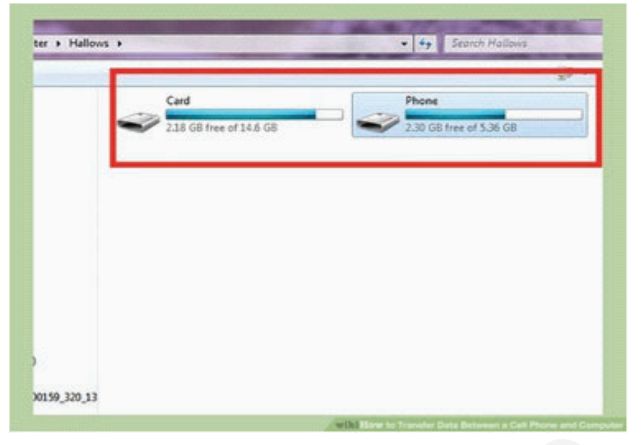

Fig 6



**Flash the various brands of cell phones/smart phones**

**Objectives :** At the end of this exercise you shall be able to  
 • **flashing the various brands of cell phone/smart phone.**

Requirements	
<b>Tools/Equipment/Instruments</b>	<b>Materials/ Components</b>
<ul style="list-style-type: none"> <li>• Cell phone/ Smart phone with SD card - 1 No.</li> <li>• Data connection to the Cell phone - 1 No.</li> </ul>	<ul style="list-style-type: none"> <li>• User Manual - as reqd.</li> </ul>

**PROCEDURE**

**TASK 1 : Flashing the various brands of cell phone/smart phone**

1 Download and install Android USB driver on your computer.

**In case Android USB drivers are already installed on your computer then do the step 2.**

2 Power off your Android smartphone and remove the battery. (If it is removable) (Fig 1)

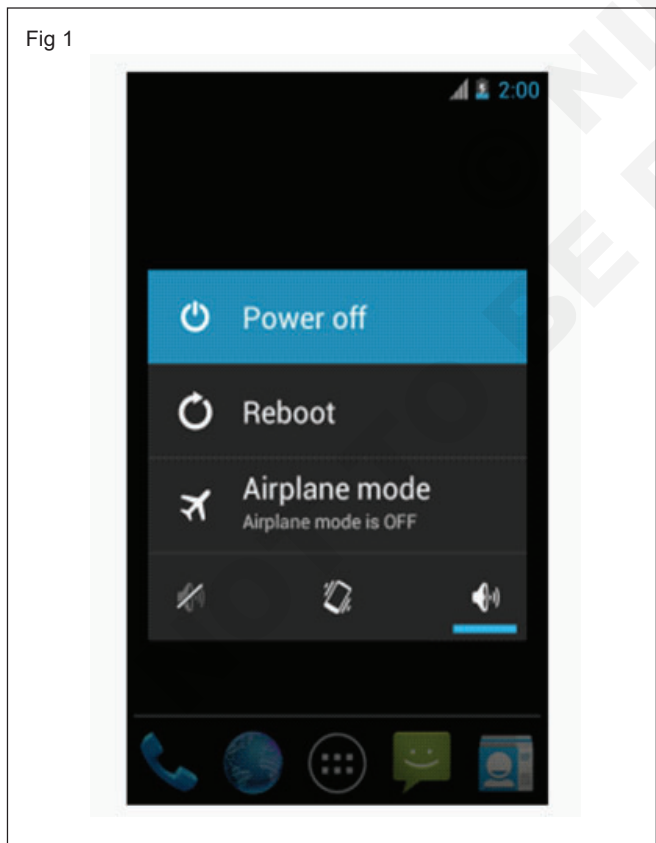

**Precaution**

- 1 Brand and model must be same you can verify/ net confirm your smart phone.
- 2 Never downgrade android version of your smart phone.
- 3 Before trying anything make a complete backup of your data in a computer.
- 4 The above tutorial only works with the stock firmware or custom ROM which comes with the scatter file in it.
- 5 Take a backup of your important data before using the smart phone flash tool because during the flashing process your personal data will be removed permanently.

- 3 Download the stock ROM or custom ROM software that you want to flash on your Android smartphone and copy it on your computer.
- 4 Download and copy smart phone flash tool on your computer.
- 5 Now open Flash\_tool.exe
- 6 Click on the Download tab.
- 7 In the download tab, now click on the scatter-loading button.
- 8 Now, locate the scatter file (you will find the scatter file in the stock rom folder).
- 9 Now, click on the download button to begin the flashing process.
- 10 Now, connect your smartphone to the computer using USB cable (without battery - if it is removable).

**Format the cell phone/smart phone for virus(approch the mobile repair shop, service center)**

**Objectives :** At the end of this exercise you shall be able to

- format the android phones using basic reset option
- format the android phone using recover reset option.

**Requirements**

**Tools/Equipments/Instruments**

- Cell phone/ Smart phone with SD card - 1 No.
- Precision screw driver set - 1 Set.

**Materials/ Components**

- User Manual - as reqd.

**PROCEDURE**

**TASK 1 : Formatting the android phones using basic reset option**

**Caution : Backup all data before resetting operation.**

Fig 1

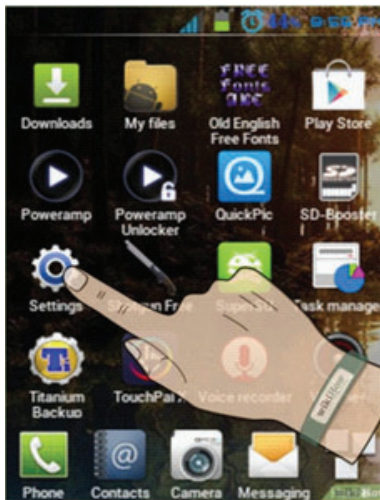

Fig 2

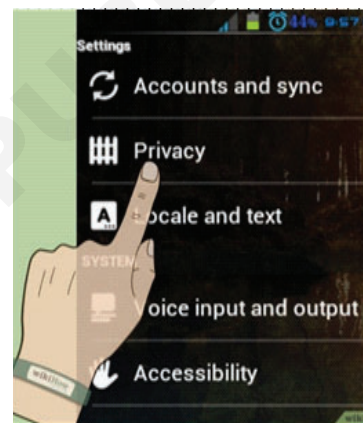
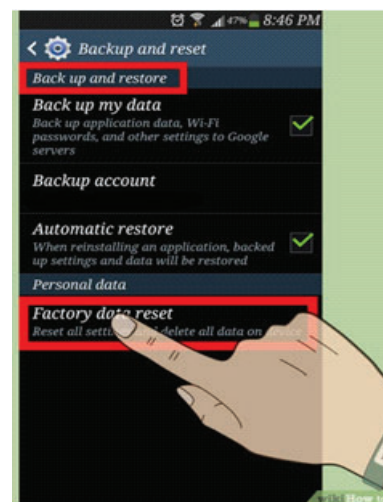

Fig 3



1 Press menu button and select setting option. (Fig 1)

**Setting can access from tab scroll also.**

- 2 Scroll the menu and select the privacy option. (Fig 2)
- 3 Scroll the menu and select factory reset option. (Fig 3)
- 4 Press the warning message OK.
- 5 Select SD card if it need format and select everything erase option.(Fig 4 and 5)
- 6 After few seconds, phone will reset.
- 7 Check the screen. It looks like new phone memory.



Fig 4



Fig 5

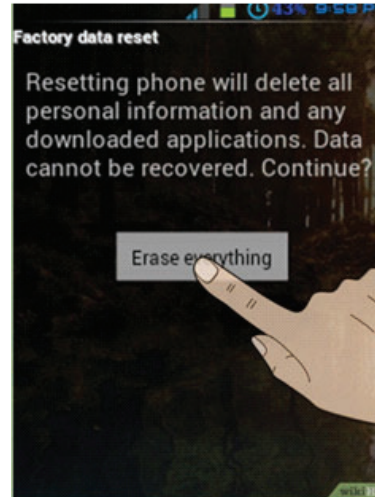

**TASK 2 : Format the android smart phone by using recovery reset option**

- 1 Press the ON/OFF button for the power OFF option to appear on your device as shown in Fig 1.

**Before you begin the reset procedure, you will need to completely power your device off.**

- 2 Press and hold the recovery buttons. (Fig 2)

**Buttons will vary from device to device. So you refer to the instruction for a particular phone. If you want to press and hold the buttons for a few seconds. Some common button combinations include:**

**Volume Up + Home + Power**

**Volume Down + Power**

**Home + Power**

- 3 Select factory reset option.

**Once the recovery menu opens, you can navigate the menu with the volume buttons. You may need to open the recovery menu to find the factory reset mode. Use the power button, some models use the camera button, to select your menu options.**

- 4 Select to confirm the factory reset.
- 5 Wait for the restore process to complete. After your phone resets, it will be set back to factory defaults and will be like new phone.
- 6 Get the work checked by the instructor.

Fig 1

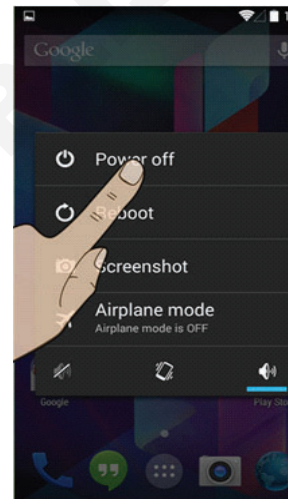

Fig 2



**Perform the interfacing of Cell phone/Smart phone to the PC and dismantle the cell phone and identify the power section and test its healthiness**

**Objectives:** At the end of the exercise you shall be able to

- perform the interfacing of cell phone/smart phone to the PC
- to synchronise the photos and folders of the cell phone to the PC
- dismantle the cell phone and identify the power section.

**Requirements**

**Tools / Equipments/ Instruments**

- Trainees tool kit - 1 Set.
- Digital multi-meter with probes - 1 Set.
- Mobile opener tools - 1 Set.

**Materials/ Components**

- Smart phone with data cable - 1 No.
- PC/Laptop - 1 No.

**PROCEDURE**

**TASK 1 : Perform the interfacing of Cell phone/Smart phone to the PC**

- 1 Switch ON the PC and install the “Phone companion” App in your PC. The phone companion app is built directly into window 10.

**If windows 10 version is not available, download the app from internet and use it for exercise.**

- 2 Enter your phone number for registering/adding your phone in the app. Then one time automated message will be sent from the Microsoft to your registered cell phone number. Consent is not necessary to get or use the app.
- 3 When the app launches, you will see the first phone companion screen, as shown in Fig.1 on the monitor.
- 4 Click on your type of phone (like, windows/android/ iPhone), and then connect your cell phone to your computer. After selection of the phone type, phone companion app will show the display as shown in Fig.2.

Fig 1

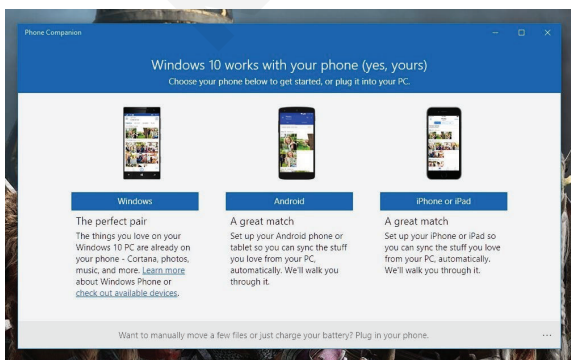

Fig 2

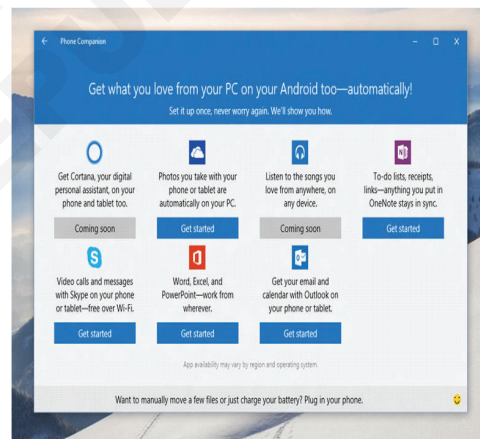
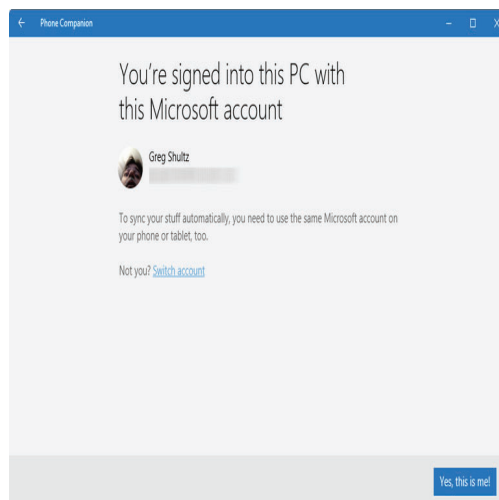
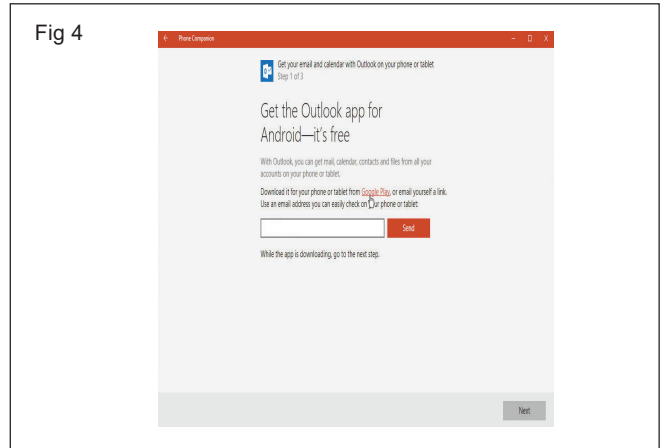

Fig 3



- 5 Select the desired application say onenote to set up in the PC sign into that one application, phone companion will identify that you are signed into your windows system with a Microsoft account and prompt you to confirm, as shown in Fig.3.
- 6 Verify your Microsoft account, you will be prompted to begin the procedure of getting the one note app for the smart phone, as shown in Fig.4
- 7 Access all the notes that you have created in windows, the onenote app is synched up.
- 8 Get the work checked by the Instructor.



## TASK 2 : To synchronise the photos and folders of the cell phone to the PC

- 1 Connect the USB data cable from your computer's USB port to your cell phone. The phone companion lists you phone's available storage space and available apps as shown in the Fig.1 to synch the photos & folders.
- 2 Choose which app to install, and whether to transfer photos or files. The phone companion leaves you with three options.

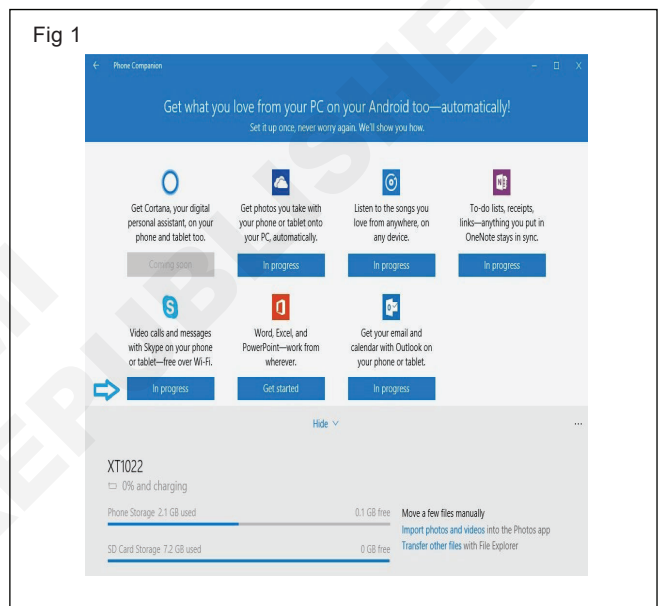

**Install Apps:** The phone companion lists the windows apps available your phone. Install the onedrive app, for example, to give your phone access to your onedrive files. You can also install cortana, music, onenote, skype, word, Excel, powerpoint, and outlook - the same apps that work on your PC. By installing the apps, you can edit your onedrive files with word, both on your phone and your PC.

**Import photos and videos:** Choose this option to copy your photos and videos from your phone or tablet to your PC.

**Transfer other files:** This option brings up file explorer, where you can view the files and folders on your tablet. Then you can transfer items from your phone or tablet to your PC or vice versa.

## TASK 3: Dismantle the cell phone and identify the power section

- 1 Switch OFF the cell phone and remove the battery cover and back facial of the cell phone.

**The screws must be kept very carefully for reassemble the cell phone**

- 2 Remove the battery, SIM card and memory card carefully.
- 3 Using suitable screwdriver, unscrew and remove all the screws and keep them in a safe box.

- 4 Once all the screws are open, remove the front cover or the front fascia of the mobile phone.

**The phone PCB is attached with the internal fascia or skeleton of the mobile phone using screws.**

- 5 Unscrew and open all the screws of the main assembly.

**Safety: It is very delicate part, handle with care.**

- 6 Remove connectors for display, camera and pull the display and the camera out as shown in Fig 1
- 7 Identify the power IC, and other supporting ICs.
- 8 Record the IC numbers/details in Table-1.
- 9 Get the work checked by the instructor.

**The IC around which there are several capacitors is called power IC. In some cell phones there are 2 power ICs.**

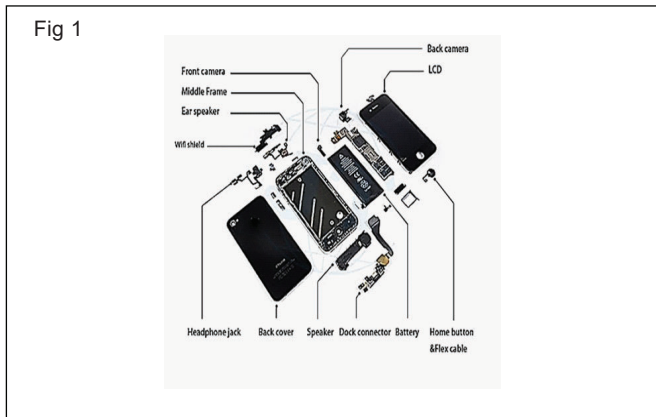

**TASK 3: Test the healthiness of cell phone power**

- 1 Keep the battery separately and set it down on flat surface such that the terminals are facing you.
- 2 Note the specification of the battery and identify the two terminals on the battery that are labeled with '+' and '-' sign as shown in Fig.1

- 4 Compare with the rating of battery and observe the healthiness of the power supply of the cell phone.
- 5 Get the work checked by the instructor.
- 6 Carefully insert the display, camera and its connectors carefully.
- 7 Reassemble the cell phone, with respective screws.
- 8 Insert the memory card, SIM card and battery.
- 9 Switch ON the cell phone and check its working condition.
- 10 Get the work checked by the instructor.

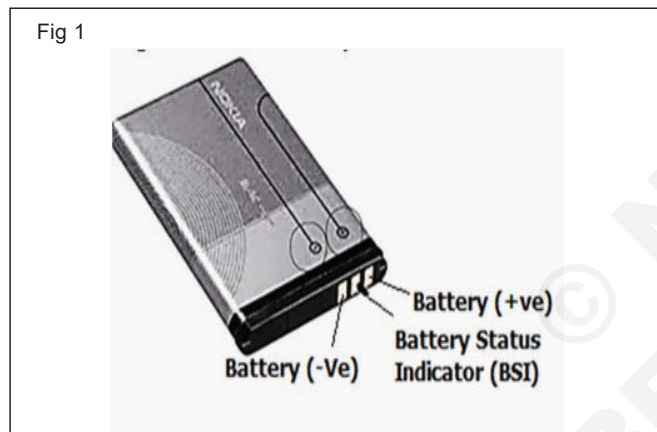

- 3 Measure and record the battery voltage, using multi-meter in Table-1.

**Table 1**

SI.No	IC No.	Function	Remarks

**Table 2**

Battery voltage Rating	Measured voltage of battery	Remarks

**Find out the fault of basic cell phone system. Rectify the fault in ringer section and check the performance**

**Objectives :** At the end of this exercise you shall be able to

- identify and defective parts of cell phone/smart phone and also replace the defective parts.

Requirements	
<b>Tools/Equipments/Instruments</b> <ul style="list-style-type: none"> <li>• Cell phone/ Smart phone with SD card - 1 No.</li> <li>• Precision screw driver set - 1 Set.</li> <li>• Soldering and desoldering station - 1 No.</li> <li>• Digital multimeter with probes - 1 No.</li> <li>• Trainees tool kit - 1 Set.</li> </ul>	<b>Materials/Components</b> <ul style="list-style-type: none"> <li>• IPA solution - 1 bottle.</li> <li>• Elma solution bottle - 1 No.</li> <li>• Required materials - as reqd.</li> <li>• Jumper wire - as reqd.</li> <li>• User manual - as reqd.</li> </ul>

**PROCEDURE**

**TASK 1 : Fault finding on phone**

- 1 Pick the defective phone and its manual.
- 2 Check the physical defects and problems on phone note and record your observations in Table 1.

**Table 1**

Make _____		Model No _____
Sl. No.	Observed	Defects/Problems

- 6 Note down the observed problems/defects.
- 7 Refer to the troubleshooting chart TSC-1 comprising of list of probable faults and their remedies.
- 8 Now refer the given table for tracing the fault.
- 9 Switch OFF the phone and remove the battery.
- 10 Dismantle the phone as given in previous exercise
- 11 Trace the section and defective parts.
- 12 Replace them.
- 13 Assemble the phone and check the function/working condition.
- 14 Get the work checked by the instructor.

- 3 Note the symptoms given by instructor. (or customer)
- 4 Switch ON the phone [For possible phones only]
- 5 Observe the health function like sound, speaker, screen, keypad, etc.

-----

**Replace various faulty parts like mic, speaker, charging/audio jack etc**

- Objectives:** At the end of the exercise you shall be able to
- identify the nature of audio related fault in the given cell phones
  - dismantle the faulty cell phone/smart phone
  - troubleshoot/ replace the defective parts of given cell phone.

Requirements	
Tools/Equipments/Instruments	Materials/ Components
<ul style="list-style-type: none"> <li>• Cell phone/ Smart phone with SD card- 1 No.</li> <li>• Precision screw driver set - 1 Set.</li> <li>• Digital multimeter with probes - 1 No.</li> <li>• Trainees tool kit - 1 set.</li> </ul>	<ul style="list-style-type: none"> <li>• Ultrasonic tub - 1 No.</li> <li>• IPA or CTC solution - as reqd.</li> <li>• User manual - as reqd.</li> <li>• Spare parts(Speaker/Mic/Jack) - as reqd.</li> </ul>

**PROCEDURE**

**TASK 1 : Checking and replacing the speaker of a cell phone**

- 1 Switch ON the cell phone and operate volume keys, check speaker sound by play any sound file like music.
- 2 Switch OFF the phone now and dismantle the phone by referring Exercise 2.14.235
- 3 Remove the speaker connection and check the continuity.
- 4 Replace the speaker with similar one if found defective.
- 5 Check the tracks of speaker upto the audio IC.
- 6 Clean the track using CTC solution.
- 7 Check the continuity of track using multimeter.
- 8 Join the defective tracks.
- 9 Warm the audio IC by using test lamp or by soldering station temp. at 250°C and blower at 5.
- 10 Now assemble the phone and switch ON.
- 11 Check phone sound. If not proper discuss with the instructor for replacing of IC.

**TASK 2 : Testing and replacing of mic**

- 1 Check the mic healthiness by recording voice or by making a call.
- 2 Switch OFF the phone and dismantle the phone by referring exercise 2.14.235
- 3 Remove the MIC connection and clean the dust using pump blower.
- 4 Check the continuity of MIC with the help of your instructor.
- 5 Check tracks of MIC upto the audio IC.
- 6 Replace the MIC with similar one if found defective.
- 7 Clean the track using CTC or IPA solution.
- 8 Check the continuity of track using multimeter.
- 9 Join the defective tracks.
- 10 Warm the audio IC by using test lamp or by soldering station temp. at 250°C and blower at 5.
- 11 Now assemble the phone and switch ON.
- 12 Check the phone sound. If sound is not proper contact instructor for replace IC.

**Condenser MIC will not give continuity.**

**For audio IC defect, mostly speaker and MIC will not functioning.**

### TASK 3 : Testing and replacing data/charging/audio jack

- 1 Connect the charger to phone and check the signal of charging indication on the screen.
- 2 Transfer the data from phone to PC using data cable.
- 3 Switch OFF the phone if the jack is found to be defective and dismantle by referring the previous exercise.
- 4 Desolder the audio jack and replace it with similar one.
- 5 Switch ON the phone and check the healthiness of phone.
- 6 Get the work checked by the instructor.

© NIMI  
NOT TO BE REPUBLISHED

**Dismantle the LED light, identify the connections of LED stacks, protection circuit and regulator**

**Objectives :** At the end of this exercise you shall be able to

- dismantle the LED light and identify the connection of LED stack
- identify the protection circuit components in the LED driver boards.

**Requirements**

**Tools/Equipments/Instruments**

- Trainees tool kit - 1 Set.
- Digital multimeter with probes - 1 Set.
- Magnifying lenses with lamp - 1 Set.

**Materials / Components**

- LED lamp - as reqd.
- LED driver boards (different wattage ratings) - as reqd.

**PROCEDURE**

**TASK 1 : Dismantling the LED light, identification of connections and the regulator section in LED light**

1 Remove the screw from the LED light as shown in Fig 1.



2 Dismantle the LED driver from the LED lamp as shown in Fig 2 under the guidance of the Instructor.



3 Remove the driver board from the LED lamp as shown in Fig 3.



4 Identify the anode, cathode terminals of each LED in the series stack and draw the circuit connection.

5 Get the traced circuit checked by the Instructor.

6 Compare the different wattage and types of LED driver boards as shown in Fig 4.

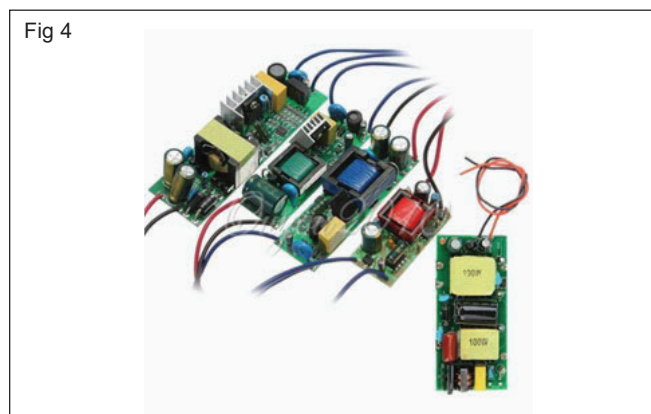



- 7 Identify the regulator IC/ Protection IC and other devices in the LED driver boards record the observations in Table 1.
- 8 Repeat the step 1 to step 7 for all other LED driver.
- 9 Get the work checked by the instructor.

**Table 1**

Sl.No.	Name of the regulator IC/ Protection IC or diode

-----

© NIMI  
NOT TO BE REPUBLISHED

**Identify the rectifier, controller part of LED lights**

**Objectives :** At the end of this exercise you shall be able to

- dismantle the LED lamp identify the rectifier circuit
- identify the Controller/ Regulator part of LED light.

Requirements	
<b>Tools/Equipments/Instruments</b> <ul style="list-style-type: none"> <li>• Trainees tool kit - 1 Set.</li> <li>• Digital multimeter with probes - 1 No.</li> <li>• Magnifying lenses with lamp - 1 No.</li> </ul>	<b>Materials / Components</b> <ul style="list-style-type: none"> <li>• Different type and wattage LED - as reqd.</li> <li>• LED driver circuit - 1 No.</li> <li>• LED Lamp - 1 No.</li> </ul>

**PROCEDURE**

**TASK 1 : Dismantle the LED lamp and identify the rectifier section**

- 1 Follow the step 1 to 5 of Task 1 in the Exercise 2.15.243.
- 2 Identify the AC input section in given LED stack or driver.
- 3 Check if any current limiting resistor is available in the circuit board. Note the value of resistor as shown in Fig 1 otherwise take the multimeter set ranges in resistor mode to measure the value of resistor and note down value and wattage in Table 1.
- 4 After the current limiting resistor section if any diode or bridge rectifier IC present means note down the diode name or IC name in TABLE 1.
- 5 Observe the other driver circuit as shown in Fig 2 and record your observations in TABLE 1.

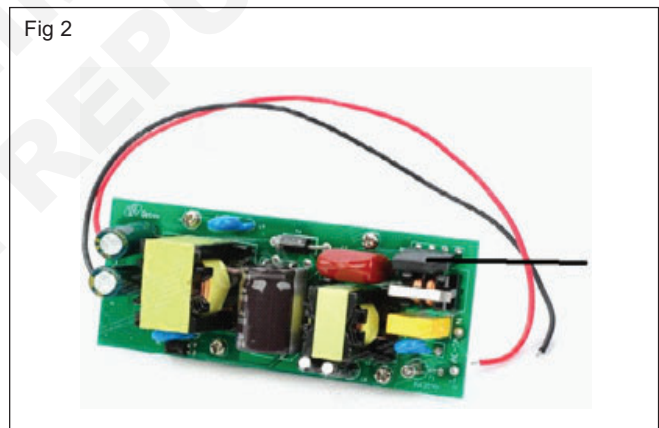
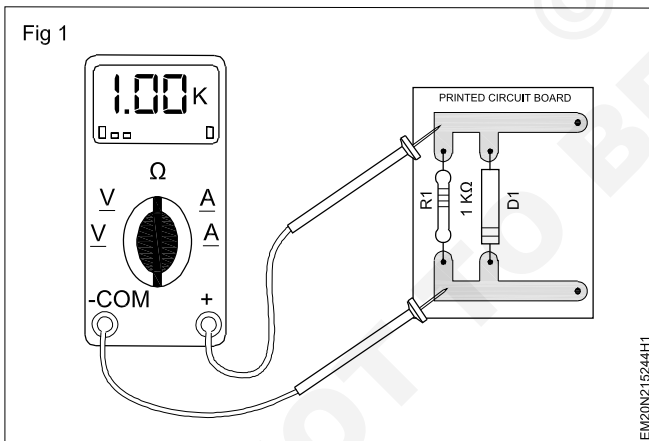

- 6 Repeat the steps for all other LED stacks or driver.
- 7 Get the work checked by the instructor.

**Table 1**

SI.No.	Current limiting resistor value	Rectifier IC name	Rectifier diode

**TASK 2 : Identify the control section/ regulator in LED driver PCB**

1 Identify the rectifier circuit as shown in Fig 1 and note down the parts name in Table 2.

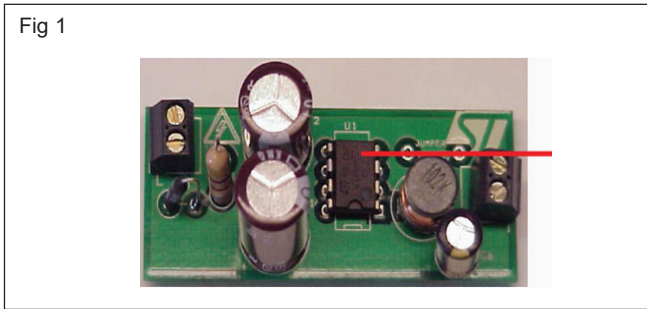

2 Get the work checked by the instructor.

-----

**Table 2**

Sl.No.	Control section part name/number

© NIMI  
NOT TO BE REPUBLISHED

**Make series strings connection of six LEDs and connect four series strings in parallel**

**Objectives:** At the end of the exercise you shall be able to

- construct a series string connection of 6 LEDs and connect 4 series strings in parallel
- test and observe the circuit operation.

<b>Requirements</b>			
<b>Tools/Equipments/ Instruments</b>			
• Trainees tool kit	- 1 Set.	• Electrolytic capacitor 1000mF/50V	- 1 No.
• Digital multimeter with probes	- 1 No.	• White LED 5mm	- 24 Nos.
<b>Materials/Components</b>		• Resistor 120W, 1/2 W	- 4 Nos.
• Step down transformer		• Power cord, 2 mtrs	- 1 No.
230V/24V, 1A	- 1 No.	• Hook - up wire	- as reqd.
• Diode - IN4007	- 4 Nos.	• General purpose PCB/Bread	
		• Board	- 15W.

**PROCEDURE**

- 1 Collect the components and check them for its good working condition.
- 2 Connect the components and construct a series string connection of six LEDs and connect four series strings in parallel as shown in Fig.1
- 3 Avoid loose connections when connecting the LED strings.
- 4 Connect AC mains to the transformer and switch ON the mains.
- 5 Measure and record the LED voltage and string voltage in the Table -1

**Table 1**

Voltage across LED	Voltage across series string				Voltage across parallel string
	A	B	C	D	

**Retain the wired 6x4 matrix LED circuit as the source is required to carry out the exercise 2.15.246. You may disconnect the transformer and bridge circuit as these are not required.**

Fig 1

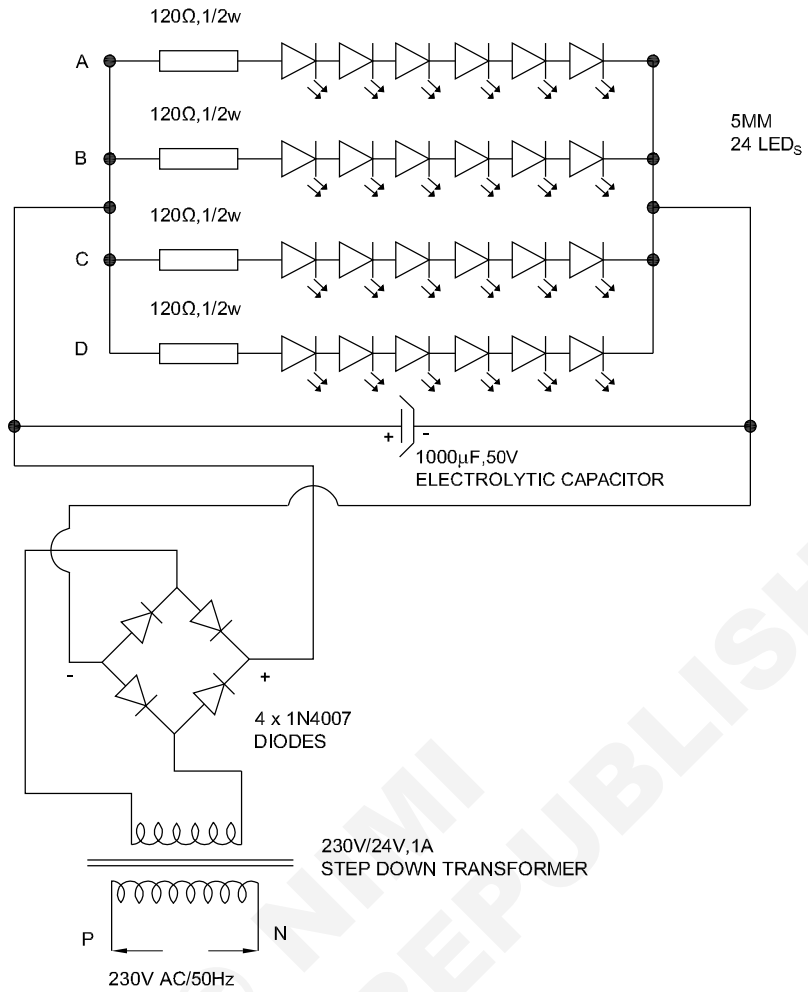

6 Get the work checked by the instructor.

-----

**Connect to such parallel sets in series to create a matrix of LEDs**

- Objectives:** At the end of the exercise you shall be able to
- construct a 6x4 matrix LEDs (End product of Ex.2.15.245)
  - assemble 4 Nos. of 6x4 matrix LEDs to create a LED array.

Requirements	
<b>Tools / Equipments/ Instruments</b> <ul style="list-style-type: none"> <li>• End product of Ex.4.7.293</li> <li>• Regulated DC power supply unit (0-30)V, 2A - 1 No.</li> <li>• Digital multimeter with probes - 1 No.</li> </ul>	<b>Materials/ Components</b> <ul style="list-style-type: none"> <li>• Connecting wires - as reqd.</li> </ul>

**PROCEDURE**

- 1 Construct four number of 6x4 matrix LEDs

**Use end products of exercise 2.15.245/Previous Exercise**

- 2 Interconnect the matrix LEDs using Hook up wires by referring the Fig.1

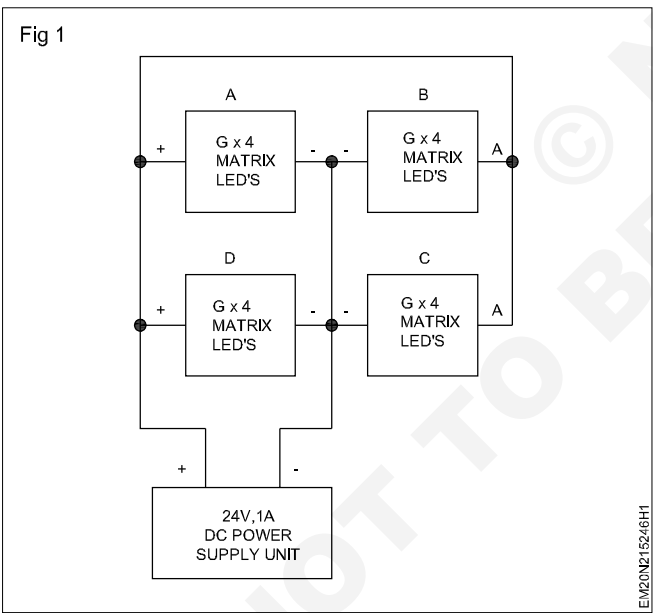

- 3 Set the DC PSU voltage at 24V and connect with the wired LED array.
- 4 Switch ON the DC PSU and check the uniform intensity of the LED.

**Do not dismantle the circuit use the same assembled a circuit for exercise 2.15.247**

- 5 Get the work checked by the instructor.

**Apply suitable voltage and check voltage across series strings**

**Objectives:** At the end of the exercise you shall be able to

- construct 4 numbers of 6x4 matrix LEDs to create a LED array
- apply suitable voltage to the LED array and check voltage across series strings.

Requirements		
<b>Tools / Equipments/ Instruments</b>		<b>Materials/ Components</b>
<ul style="list-style-type: none"> <li>• End product of Ex.4.7.293</li> <li>• DC power supply 0-30V/2A - 1 No.</li> <li>• Digital multimeter with probes - 1 No.</li> </ul>		<ul style="list-style-type: none"> <li>• Connecting wires - as reqd.</li> <li>• Patch cords - as reqd.</li> </ul>

**PROCEDURE**

- 1 Construct four number of 6x4 matrix LEDs to create a LED array by referring the Fig.1
- 2 Set the DC PSU voltage at 24 V and apply to the wired circuit.
- 3 Measure and record the following
  - a Circuit input DC voltage
  - b Voltage across each 6x4 matrix LED
  - c Voltage across series strings
  - d Voltage across LEDs.
- 4 Tabulate the readings and observe voltage levels at different points of the circuit.
- 5 Switch OFF the DC power supply unit.

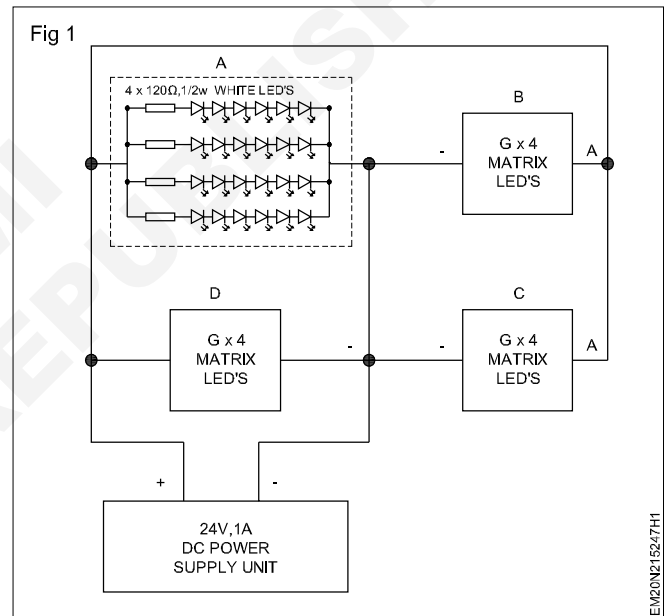

**Table 1**

Input DC voltage	Voltage across				Voltage across series string	Voltage across any LED.
	A	B	C	D		

**Identify and operate different controls on LCD, LED TV**

- Objectives :** At the end of this exercise you shall be able to
- identify the different indicators/controls on LCD and LED TV
  - identify the different connectors in LCD and LED TV.

Requirements	
<b>Tools/Equipments/Instruments</b>	<b>Materials/ Components</b>
• LCD or LED TV with user manual - 1 No.	Nil

**PROCEDURE**

**TASK 1 : Identify the different front panel indicators/controls LCD and LED TV**

- 1 Pick up any one of the TV from the Lab, see the front panel as shown in Fig 1.

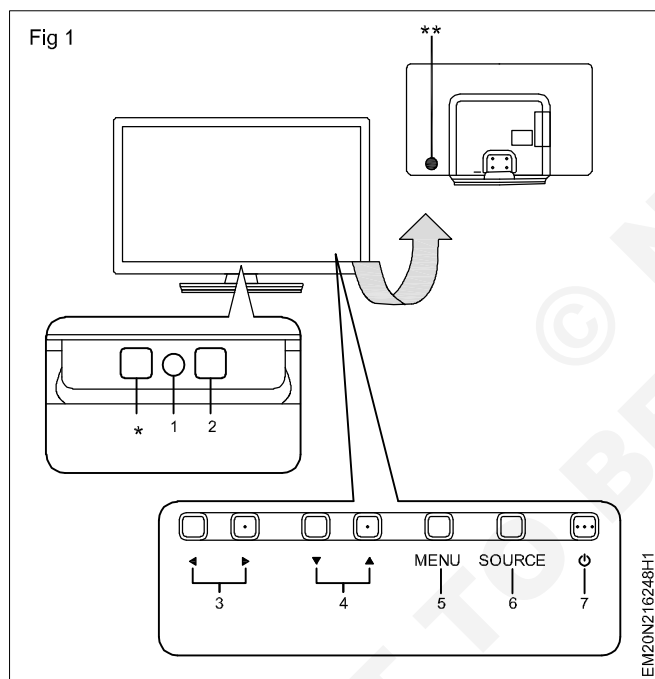

- 2 Identify the various front panel indicators/controls available in TV note down in the Table 1.
- 3 Get the work checked by the instructor.
- 4 Repeat the above steps for other TVs.

**Table 1**

SI.No.	Front panel Controls name
*/**	
1	
2	
3	
4	
5	
6	
7	

**TASK 2 : Identify the different input and output or audio and video connectors in LCD TV and LED TV**

- 1 Pick up any one of the TV from the lab, see the back side and side view of the TV panel as shown in Fig 1.
- 2 identify the input and output connector or audio and video connectors in TV note down your observations in the Table 2.

- 3 Get the work checked by the instructor.
- 4 Repeat the above steps for other TVs.



Fig 1

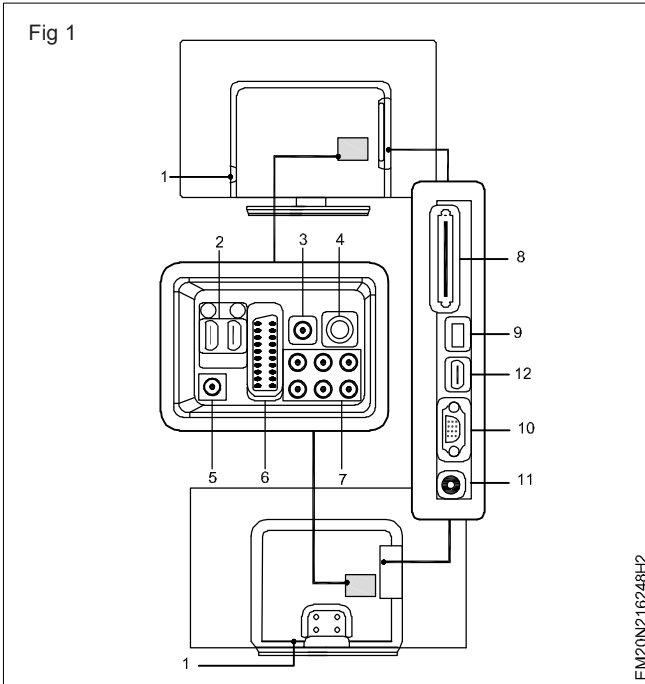

Table 2

Sl.No.	Connector name
1	
2	
3	
4	
5	
6	
7	
8	
9	
10	
11	
12	

-----

© NIMI  
NOT TO BE REPUBLISHED

## Identify components and different sections of LCD and LED TV

**Objectives :** At the end of this exercise you shall be able to

- dismantle the back panel cover of the LCD TV
- identify the internal sections in LCD TV.

### Requirements

#### Tools/Equipments/Instruments

- LCD TV with user manual - 1 No.
- Trainees tool kit - 1 Set.
- ESD table - 1 No.

#### Materials/ Components

- Soft cloth (to keep the screen protected from scratches) - as reqd.

### PROCEDURE

#### TASK 1 : Remove the back panel cover of the LCD TV and identify the sections

- 1 Unplug the LCD TV from its power supply and remove any other cables from the TV as shown in Fig 1.

Fig 1

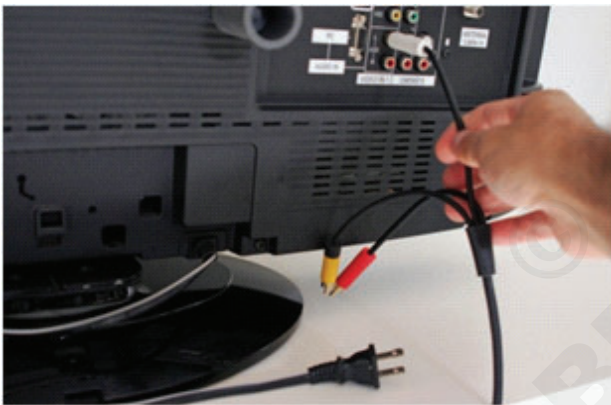

- 2 Prepare the ESD table or any other flat surface and lay the soft cloth on it.
- 3 Turn the LCD TV face down on the soft cloth, to protect the screen from being damaged.
- 4 Remove the four screws that hold the base in place. The screws are located in the centre of the TV near the bottom as shown in Fig 2.

Fig 2



- 5 Remove the stand from the back of the LCD TV and keep it aside.
- 6 Place the screw driver in between the covers as shown in Fig 3 and with little force twist and open a gap.

Fig 3



- 7 Turn the screw driver to unlock/and open the panel. Use this technique around all the sides of the TV monitor as shown in Fig 4.

Fig 4



8 Remove the outer cover to show the main body of the TV monitor as shown in Fig 5.

Fig 5



9 Remove the side panel screws as shown in Fig 6.

Fig 6



10 Get the work checked by the instructor.

**TASK 2 : Identify the different components used in LCD TV**

1 Identify the different internal section in LCD TV as shown in Fig 1.

2 Note down the name of different section in Table 1.

**Don't remove any cables from the TV.**

3 Get the work checked by the instructor.

**Table 1**

Sl.No.	Name of the Section
1	
2	
3	
....	
....	
14	

Fig 1

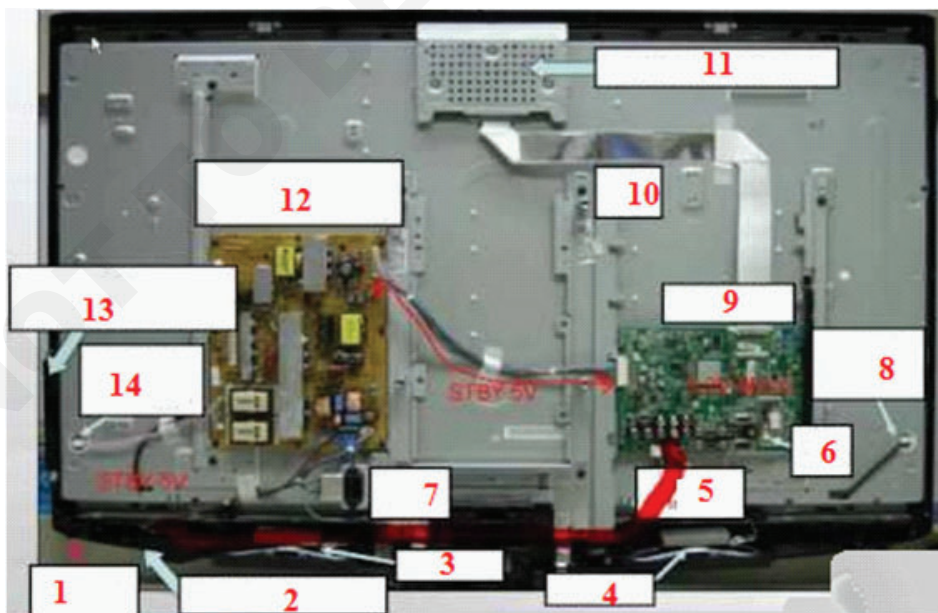

**Dismantle, identify the parts of TV remote control**

- Objective :** At the end of this exercise you shall be able to
- identify the remote control model and the function keys
  - dismantle the TV remote control handset.

Requirements			
<b>Tools/Equipments/Instruments</b>		<b>Materials/ Components</b>	
• Trainees tool kit	- 1 Set.	• Cleaning brush	- 1 No
• Magnifier lens	- 1 No.	• Remote control checker, tester	- 1 No.
• TV Remote control handset with user manual	- 1 No.	• IPA cleaning solution	- 1 bottle.

**Note: The instructor has to label all the remote control handsets used for this exercise**

**PROCEDURE**

**TASK 1 : Identify the remote control model and the function keys**

- 1 Pick any one of the labeled TV remote control from the lab.
- 2 Note down the model number of the TV remote control record the observations in Table 1.

**Table 1**

Sl. No.	Label No.	Model/Serial No	Type
1			
2			
3			
4			
5			

- 3 Repeat the above step for the remaining labeled items
- 4 Take one of the labeled remote control handset, identify the name/function of the keys as shown in Fig 1 with reference to the user manual.
- 5 Record the name of each key on the remote control keypad and its function in Table 2.
- 6 Get the work checked by the Instructor.

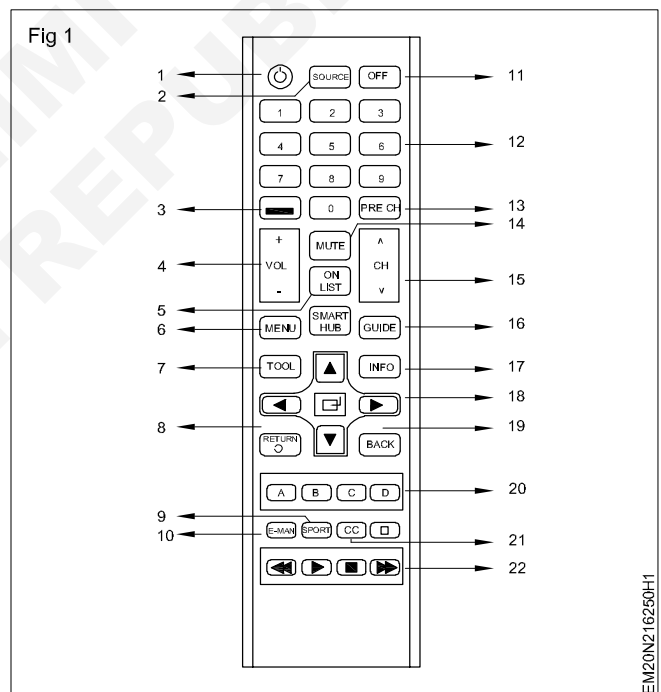
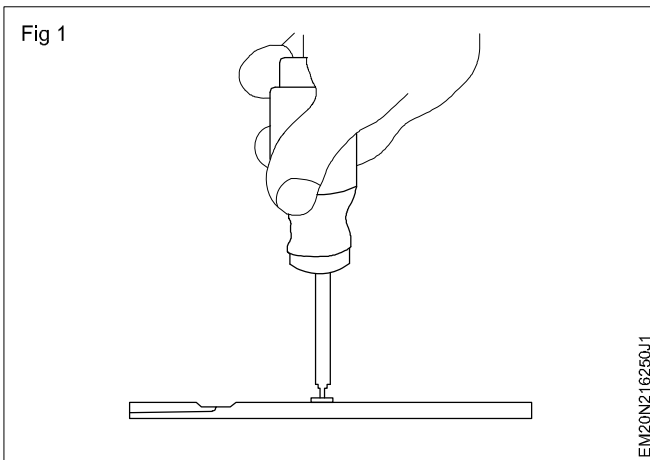

**Table 2**

Sl.No.	Button Name	Function
1		
2		
3		
4		
5		

**TASK 2 : Dismantle the TV remote control handset**

- 1 Open the battery compartment cover handset and remove batteries out of the TV remote control.
- 2 Locate and remove the fixing screws from the back cover as shown in Fig 1.



**In some models there is no screws used for fitting both top and bottom cover. Only press type locking is used. Open it carefully without damaging the locking arrangement.**

- 3 Open the remote control from its side by using a blunt knife or similar tool as shown in Fig 2.

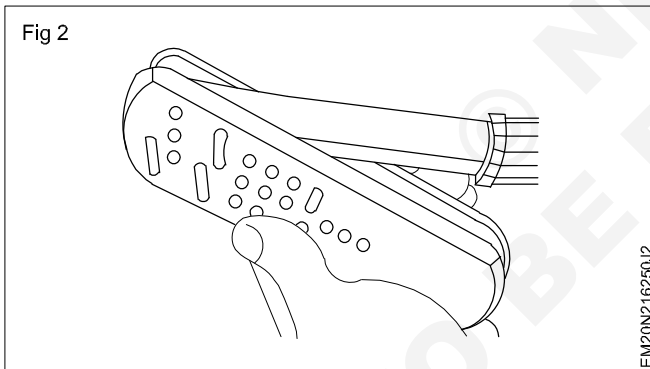

- 4 Take out the moulded rubber key pad from its PCB.
- 5 Clean the tracks and contact points on the PCB and the rubber keypad using cleaning solution with brush.
- 6 Identify all the components on the PCB and record them in Table 3.

**Table 3**

Sl.No.	Name of the component
1	
2	
3	
4	
5	

- 7 Insert the keypad buttons correctly into the slotted holes on the front panel cover of the remote control.
- 8 Align the PCB over the rubber keypad, insert the battery contacts into the back cover and fix the remote control handset.
- 9 Insert batteries, close cover and test the functioning of buttons using the remote control checker/tester.

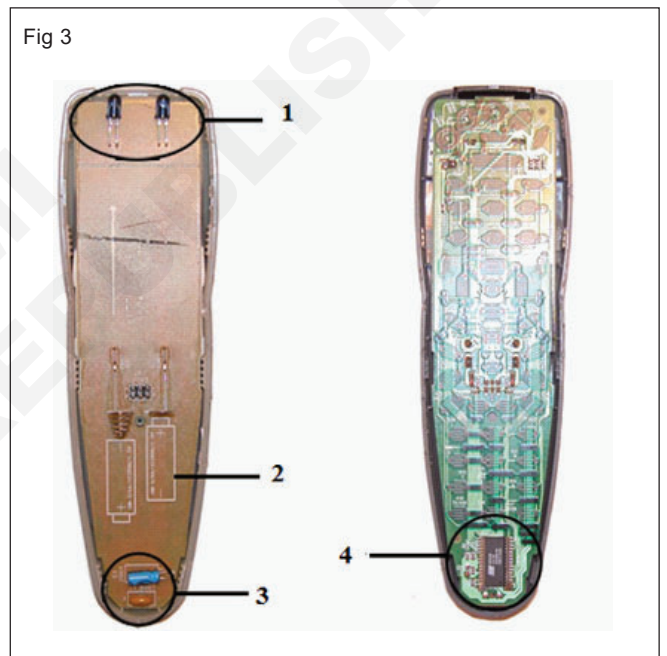

- 10 Get the work checked by the instructor.

**Dismantle the given LCD/LED TV to find faults with input stages through connectors**

**Objectives :** At the end of this exercise you shall be able to

- remove the back panel cover of LCD/LED TV
- Identify the input terminals and check them.

**Requirements**

**Tools/Equipments/Instruments**

- Trainees tool kit - 1 Set.
- Magnifier lens - 1 No.
- LCD/LED TV - 1 No.
- Home theatre system - 1 Set.
- DVD player with remote controls & user manual - 1 Set.
- Set-top box with user manuals - 1 No.

**Materials/Components**

- HDMI cable - 2 Nos.
- RCA cable 3RCA - 3RCA - 1 Set.
- Optical cable(S/PDIF) - 1 No.
- Coaxial cable 2RCA - 2RCA - 1 Set.

**Note: The instructor has to provide the LCD/LED TV with known faults in input stages**

**PROCEDURE**

**TASK 1 : Remove the back panel cover of the LCD/LED TV**

- 1 Unplug the LCD/LED TV from its power supply and remove any other cables from the TV as shown in Fig 1.

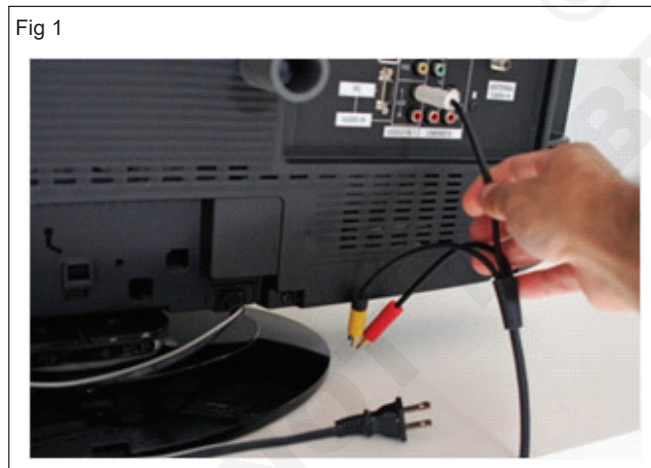

- 2 Prepare the ESD table or any other flat surface and lay the soft cloth on it.
- 3 Turn the LCD/LED TV face down on the soft cloth, to protect the screen from damage.
- 4 Select the correct size tip for screw driver and remove the four screws that hold the base stand in place. The screws are located in the centre of the TV near the bottom as shown in Fig 2.

**Keep the screws and stand aside carefully**



- 5 Place the screw driver in between the covers as shown in Fig 3 and with little force twist and open a gap.
- 6 Turn the screw driver to unlock/and open the panel. Use this technique around all the sides as shown in Fig 4.
- 7 Remove the outer cover to show the main body of the TV as shown in Fig.5 and remove the side panel screws as shown in Fig 6.
- 8 Get the work checked by the Instructor.

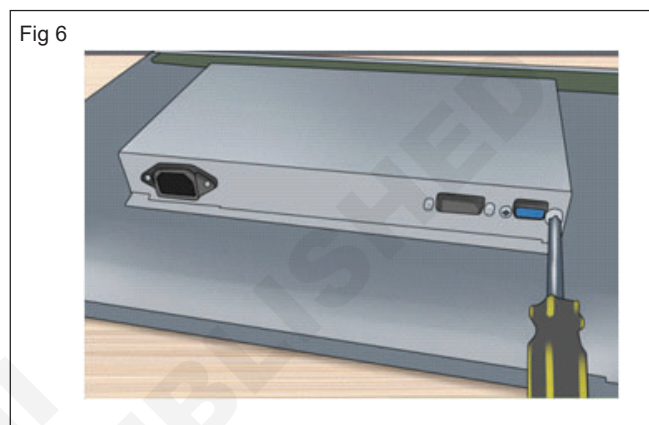

**TASK 2 : Identify different type terminals/connectors of input stage of LCD/LED TV**

- 1 Note down the type of socket/connector provided on the input stage of LCD/LED
- 2 Record your observations in Table 1 for all the input sockets.

**Table 1**

Sl. No	Name of the socket/connector	Uses/Purpose	Remarks
1			
2			
3			
4			
5			

- 3 Use magnifying lens and locate the fault by visual inspection for any desoldered/disconnected wires at the terminal sockets/connecting wires to the motherboard of the LCD/LED TV.
- 4 Resolder/rectify the identified fault and get the work checked by the instructor.

- 5 Lift the LCD/LED TV and position it carefully.
- 6 Connect the signal source using the particular type of connecting cable to the input stage of LCD/LED TV.

**Note: DVD player/set top box/laptop computer with HDMI output may be selected as the signal source for the above step**

- 7 Switch ON the setup and confirm the reception of the LCD/LED TV.
- 8 Get the approval of the instructor, switch OFF the setup, disconnect the signal source/cable.
- 9 Reposition, close the back cover on the LCD/LED TV and fix the base stand.
- 10 Get the work checked by the instructor.

**Detect the defect in a LED/LCD TV receiver given to you. Rectify the fault**

**Objectives :** At the end of this exercise you shall be able to

- **dismantle the back panel cover of the LCD/LED TV**
- **identify the internal sections in LCD/LED TV.**

<b>Requirements</b>	
<b>Tools / Equipments/ Instruments</b> <ul style="list-style-type: none"> <li>• LCD/LED TV - 1 No.</li> <li>• Trainees tool kit - 1 Set.</li> <li>• Digital multimeter with probes - 1 No.</li> <li>• User manual of LCD/LED TV - 1 No.</li> </ul>	<b>Materials/ Components</b> <ul style="list-style-type: none"> <li>• Nil</li> </ul>

**Precaution**

- 1 Remove the power cord from the mains before attempting to remove the back cover of LCD TV/ Trainer kit.**
- 2 Note down the colours of wires and position/location of connectors on the main board.**

- 3 Avoid touching the screen at all times as this may result in damage to the screen.**
- 4 Use soft cloths to keep the screen protected from scratches.**

**PROCEDURE**

**TASK 1: Back panel cover removing**

- |   |   |
|---|---|
| <ol style="list-style-type: none"> <li>1 Unplug the LCD/LED TV from its power supply and remove any other cables from the TV.</li> <li>2 Prepare the ESD table or any other flat surface and lay the soft cloth on it.</li> <li>3 Turn the LCD/LED TV face down on the soft cloth to protect the screen from being damaged.</li> <li>4 Remove the four screws that hold the base in place. The screws are located in the centre of the TV near the button.</li> </ol> | <ol style="list-style-type: none"> <li>5 Remove the stand from the back of the LCD/LED TV and keep it aside.</li> <li>6 Place the screw driver in between the covers and with little force twist and open a gap.</li> <li>7 Turn the screw driver to unlock/and open the panel. Use this technique around all the sides of the TV monitor.</li> <li>8 Remove the outer cover to show the main body of the TV monitor.</li> <li>9 Remove the side panel screws.</li> </ol> |
|---|---|

**TASK 2: Internal sections identifications**

- 1 Identify the different internal sections in LCD/LED TV as shown in Fig 1
- 2 Note down the name of different sections in Table 1.

**Note: Don't remove any cables from the TV.**

- 3 Assemble the cover after identifications and check its working condition.

**Table 1**

SI.No.	Name of the internal section	Description
1	SMPS Board	
2	Main Board	
3	T-CON Board	
4	Soft touch keyboard	
5	Speakers	
6	IR/LED board	



Fig 1

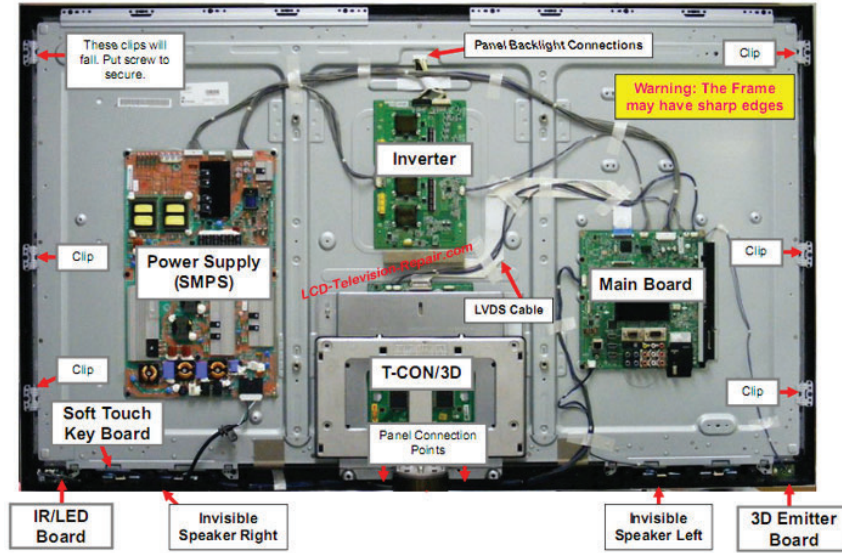

**Troubleshoot the faults in the given LED/LCD TV receiver - Locate and rectify the faults**

**Objectives :** At the end of this exercise you shall be able to

- identify the faults in the LED TV
- rectify the fault in LCD/LED TV using flowchart method.

Requirements	
<b>Tools/ Equipments/ Instruments</b> <ul style="list-style-type: none"> <li>• LCD/LED TV - 1 No.</li> <li>• Trainees tool kit - 1 Set.</li> <li>• RF cable/set top box with DTH &amp; remote - 1 No each.</li> <li>• Digital multimeter with pipe - 1 No.</li> </ul>	<ul style="list-style-type: none"> <li>• Pattern generator with operating/instruction manual - 1 No.</li> <li>• ESD table - 1 No.</li> <li>• User manual of LCD/LED TV- 1 No.</li> </ul> <b>Materials/ Components</b> <ul style="list-style-type: none"> <li>• Nil</li> </ul>

**PROCEDURE**

**TASK 1 : Symptom - No power**

- 1 Connect the colour pattern generator output to LCD/ LED TV.
- 2 Switch ON this setup and observe the screen whether any display present or not.
- 3 Switch OFF this setup and remove the back cover of the LCD/LED TV.
- 4 Unscrew the chassis/main PCB fitting screw, keep all screws, nuts, fasteners, etc. satisfy in a transparent cover.
- 5 Detach the connectors wherever possible and take the PCB out of the cabinet without stretching the soldered wire too much.
- 6 Position the PCB such that all components side face towards you.
- 7 Refer the circuit diagram of the SMPS stages of the LCD/LED TV and follow the troubleshooting flow chart shown in figure.
- 8 Locate the components of SMPS stage & check the output voltage 24V is present.
- 9 Check SMPS output voltages and record the observations in Table-1.

**Table 1**

No power	Yes/No
Whether display present	
Power board output	
Power key under control	
IR receiver normal	

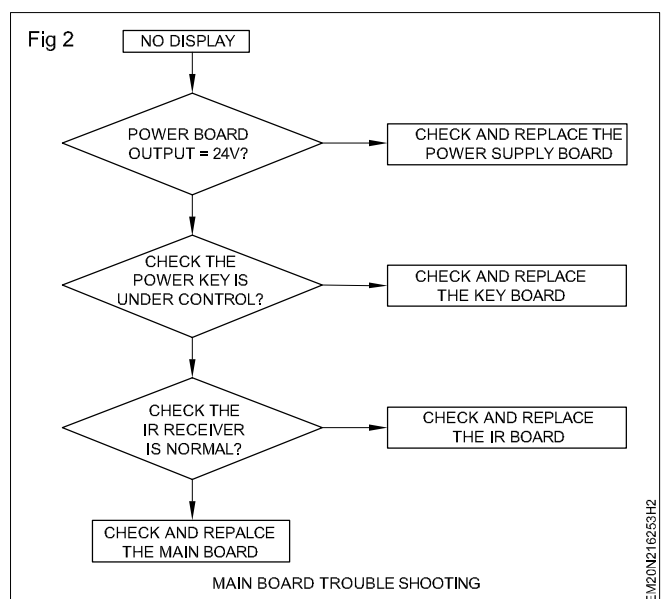
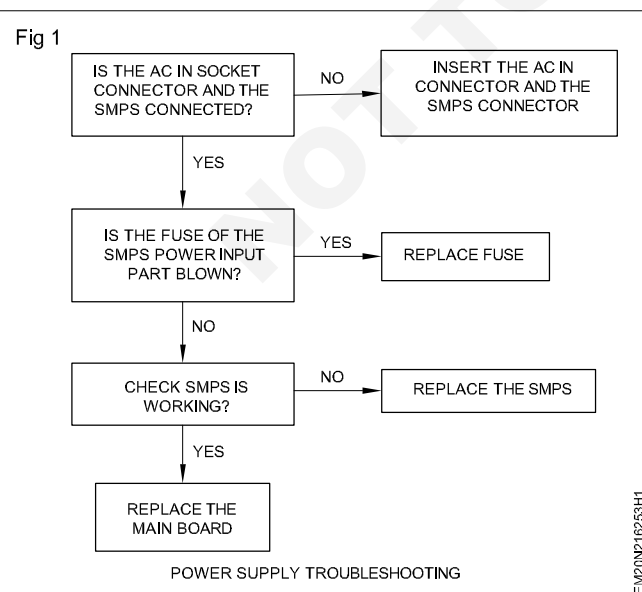

## TASK 2 : No picture and sound

- 1 Connect the colour pattern generator output to LCD/LED TV.
- 2 Switch ON this set up and check whether sound and visual display present or not.
- 3 Switch OFF and remove the back cover of LCD/LED TV and unscrew the chassis/main PCB fitting screw, keep all screw, nuts, fasteners, etc. safely in a transparent cover.
- 4 Detach the speaker wire and check the speaker.
- 5 Check the speaker cable if it is not connected well, connect it.
- 6 Check the corresponding IC voltages if voltages not available, replace it.
- 7 Follow the given troubleshooting chart and rectify the possible fault in the given TV set.

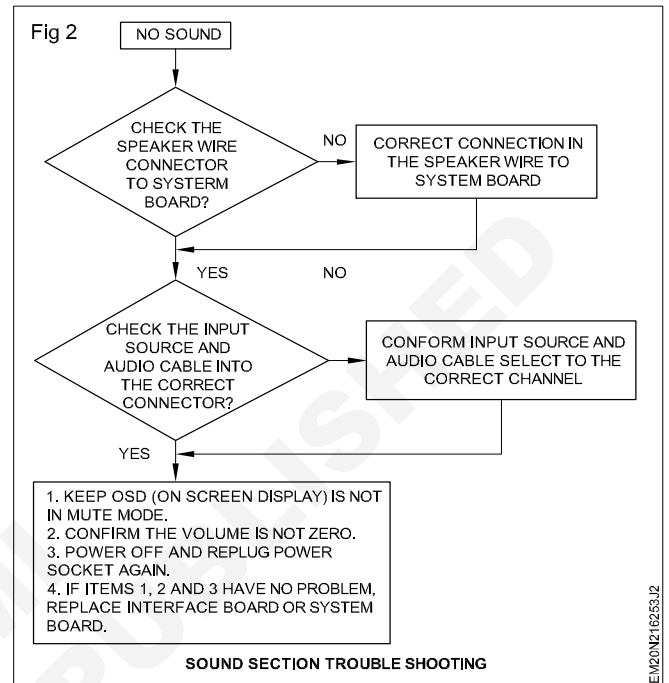
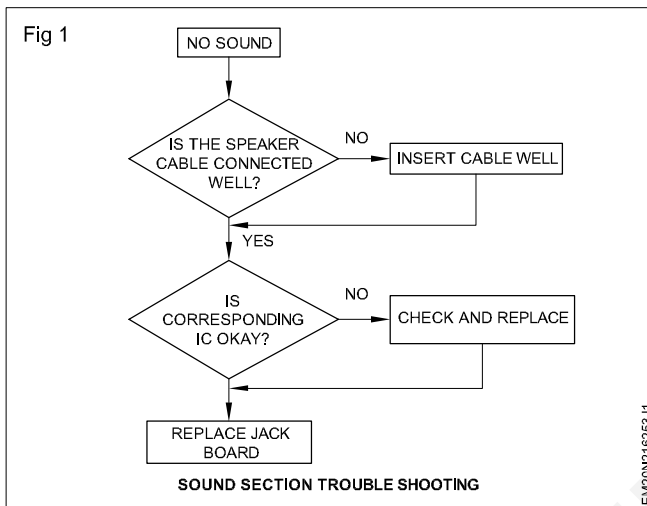

### Other trouble shooting chart for general faults

Sl. No	Symptom	Solutions
1	No picture on screen but LCD/LED TV still has sound.	The problem is cause by defective SMPS/PS board and replacing SMPS/Power supply board will solve the problem
2	Screen flash ON and OFF between 1/2 to a few seconds, but power indicator light stays ON and TV still has sound.	The problem is caused by defective mother board
3	Blue screen but no picture.	The problem is caused by defective main board (AD board). In some cases, this problem may cause by defective screen controller board. (I CON) board T CON board this board is mounting on the back of LCD TV screen.
4	Power light stays ON but no display and sound.	The problem is caused by defective main board. (AD board) or power supply board.
5	No power or power indicator light does not lits.	The problem could either by defective power supply board or defective main board (AD board).
6	No picture but TV still has sound	Check the driver output voltage to side LED/Back light LED. If there is no voltage from the driver board. check the test point at the board and replace it If voltage is available in the driver board, then problem in display. Replace the suitable display
		Check the power supply T-COW board and main board and replace it.

- 8 Get the work checked by the Instructor.

**Test LED/LCD TV after troubleshooting the defects**

**Objectives :** At the end of this exercise you shall be able to

- switch ON TV and setting the primary information
- connect and test the LCD/LED TV with media device using HDMI, RCA, USB cable.

Requirements	
<b>Tools / Equipments/ Instruments</b>	
<ul style="list-style-type: none"> <li>• LCD/LED TV - 1 No.</li> <li>• Trainees tool kit - 1 Set.</li> <li>• Media source with HDMI, RCA, USB output - as reqd.</li> </ul>	<ul style="list-style-type: none"> <li>• Digital multimeter with probes - 1 No.</li> </ul>
<b>Materials/Components</b>	
<ul style="list-style-type: none"> <li>• Nil</li> </ul>	

**Safety precaution**

- 1 Make sure to connect mains cable is properly connected with ground earth pin.
- 2 Do not plug too many electrical devices into a single multiple electrical outlet. Otherwise, this may result in fire due to over-heating.
- 3 Install the TV where there is proper ventilation. Do not cover the product with cloth or other materials while plugged.
- 4 Prevent “images burn” or “Burn - in” on the TV screen. (If a fixed image displays on the TV screen for a long period of time, it

will be imprinted and become a permanent disfigurement on the screen. This is called as “ image burn” or “burn-in”).

- 5 Avoid touching the screen at all time, as this may result in damage to the screen.
- 6 Disconnect the power card from the power outlet when you do not use the TV for long period of time.
- 7 To prevent the damage of TV, never plug the power cords until finished the work.

**PROCEDURE**

**TASK 1 : Turning the TV ON for the first time**

- 1 Connect the power cord to a power outlet. The power indicator turns red and the TV switches to standby. (Fig 1)
- 2 In standby mode, press the power button on the remote control or local key to turn the TV ON. The initial setting screen appears if you turn the TV ON for the first time.

**Note: You can also access initial setting by accessing Option in the main menu.**

- 3 Follow the on-screen instructions to customize the TV settings according to the preferences.
- 4 When the basic setting are complete, press the OK.
- 5 To turn the TV OFF, press the power button on the remote control.

**Watching TV**

- 1 In standby mode, press  (power) to turn the TV ON.
- 2 Press Input and select TV

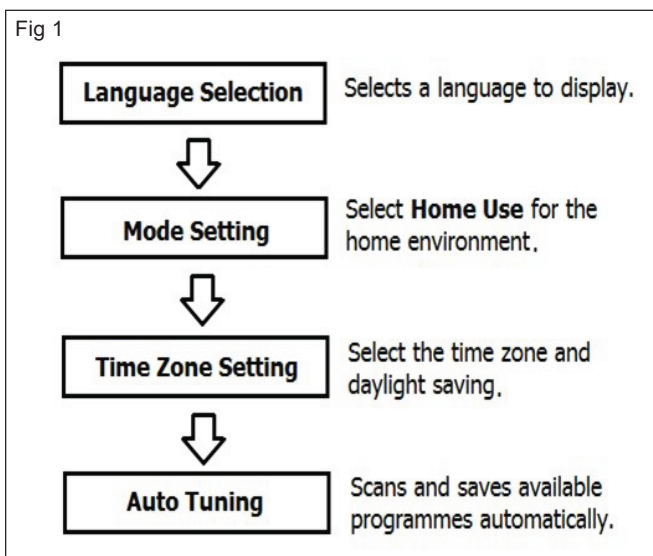

- 3 To turn the TV OFF, press  (Power). The TV switches to standby mode.

## Managing programmes:

### a Automatically setting up programme

- 1 Press Settings and the navigation buttons to scroll to Setup and press OK.
- 2 Press the navigation buttons to scroll to Auto tuning and press OK.
- 3 Press the navigation buttons to scroll to 'To start' and select 'To start' to begin auto tuning. The TV scans and saves available programmes automatically.
- 4 When you return to the previous menu, press, Back.

### b Manually setting programme

- 1 Press settings and the navigation buttons to scroll to setup and press OK.
- 2 Press the navigation buttons to scroll to manual tuning.
- 3 Press the navigation buttons to scroll to storage.
- 4 Press the navigation buttons or number buttons to select the desired programme number.
- 5 Press the navigation buttons to scroll to system.
- 6 Press the navigation buttons to scroll to TV system
- 7 Press the navigation buttons to scroll to band.
- 8 Press the navigation buttons to scroll to channel.
- 9 Press the navigation buttons to scroll to V/UHF or Cable.
- 10 Press the navigation buttons and then select the desired channel number with the navigations buttons or numbers.
- 11 Press the navigation buttons to scroll search.
- 12 Press the navigation buttons to scroll and start searching.
- 13 Press the OK to store it.
- 14 When you return to the previous menu, press, Back.
- 15 To store another programme, repeat steps 3 to 13.

## Customizing TV setting

- 1 Practice and familiarize the following customize setting
  - a Picture settings
  - b Audio settings
  - c Time settings
  - d Option settings
  - e Lock settings

## Other functions

- 1 Practice and familiarize the following functions in the LED television

- a Assigning a Station Name
- b Fine tuning
- c Adjusting aspect ratio
- d Browsing files from USB

## 1 Connecting LED television with an antenna or cable as shown in Fig 1.

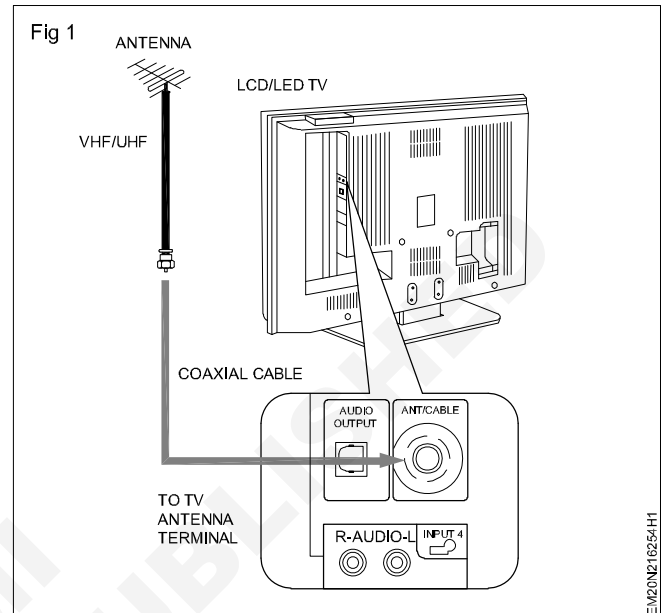

## 2 HDMI cable connection as show in Fig 2.

- Connect the HDMI cable in the input position of the TV.
- Take one end of the HDMI cable and plug terminal at the HDMI output on the media device.
- Connect the other end of HDMI cable to the HDMI input on TV.

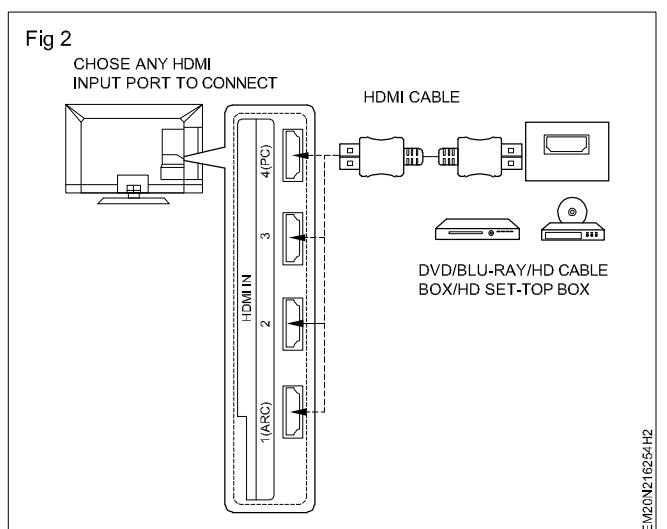

## 3 RCA cable connection as shown in Fig 3&4

- To connect TV using RCA (Composite video) match the colours of the cable and the connector of the TV.

Fig 3

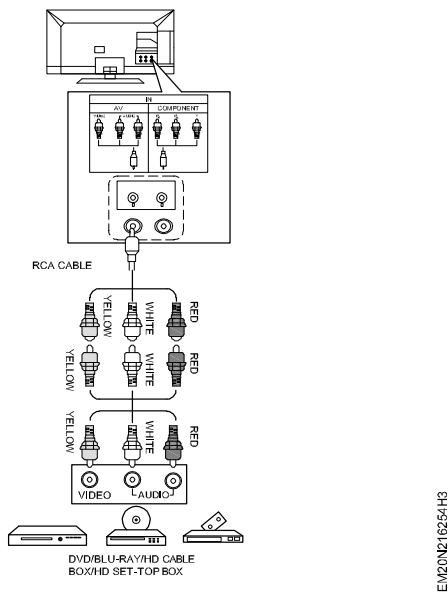

EM20N216254H3

#### 4 Component connection

- Transmits analog video and audio signals from an external device to the TV.

#### 5 Connecting to a USB (Fig 5)

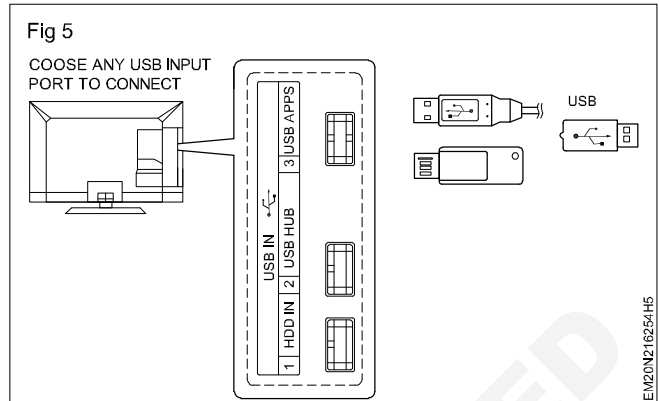

EM20N216254H5

#### 6 Connecting SET-Top box as shown in Fig 6.

- Connect the cable TV coaxial cable to the input of the set-top box.

##### RCA cable method

- Select the 3 RCA cable, follow colour coding for audio and video signal

##### HDMI cable method

- Connect the HDMI cable into the HDMI output terminal of set-top box to the TV.
- Power ON both devices and select the input of TV either RCA or HDMI.
- Tune the set-top box to the desired channel.
- Get the work checked by the Instructor.

Fig 4

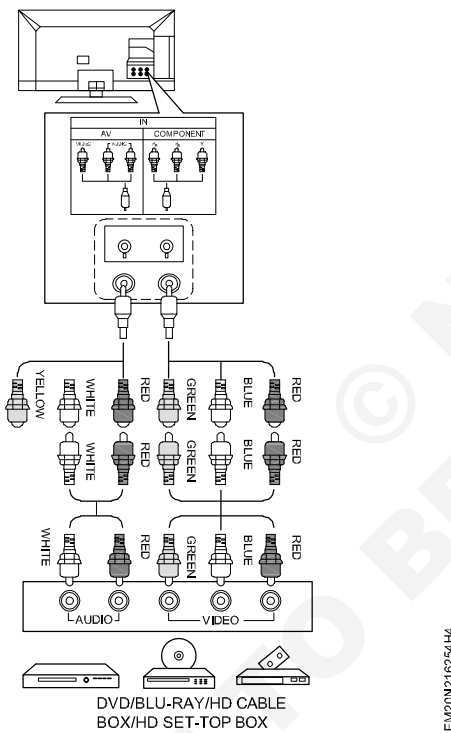

EM20N216254H4

Fig 6

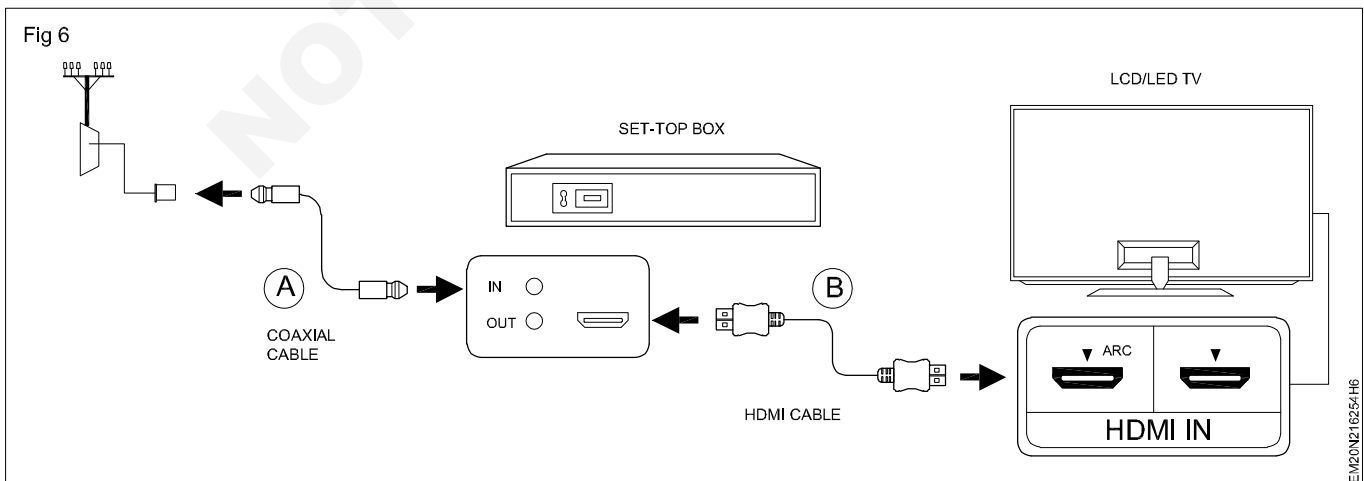

EM20N216254H6

**Identify various connectors and connect the cable operators external decoder (Set-top box) to the TV**

- Objectives :** At the end of this exercise you shall be able to
- identify different input/output connectors in set-top box
  - identify different front panel indicators/controls on set-top box.
  - connect the set top box to the TV.

Requirements	
<b>Tools / Equipments/ Instruments</b> <ul style="list-style-type: none"> <li>• Trainees tool kit - 1 Set.</li> <li>• Set - top box with user manual and cable set (3 RCA to 3 RCA / HDMI cable) - 1 Set.</li> <li>- as reqd.</li> </ul>	<b>Materials/ Components</b> <ul style="list-style-type: none"> <li>• LCD/LED TV with remote control handset - 1 Set.</li> <li>• DTH connectivity - as reqd.</li> </ul>

**Note: The Instructor has to label the input/output connectors on the front panel/rear panel of the set top box using permanent marker pen**

**PROCEDURE**

**TASK 1 : Identification of different input/output connectors in set-top box**

- 1 Pick any one of the set-top box from the lab, see the rear panel as shown in Fig 1.
- 2 Identify different input/output connectors labelled for audio/video connectors in set-top box and note down in Table 1.
- 3 Repeat the above steps for other set-top box if available in the lab.

**Table 1**

Sl.No.	Name of the rear connector/socket	Remarks
1		
2		
3		
4		
5		
6		
7		
8		
9		
10		
11		

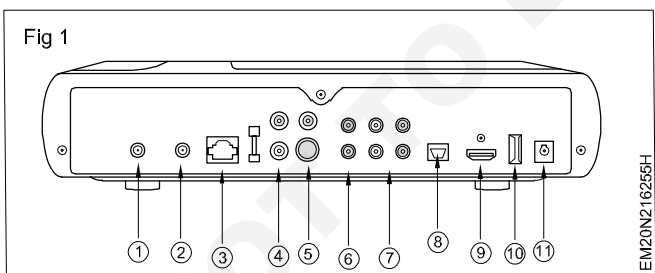

- 4 Get the work checked by the Instructor.

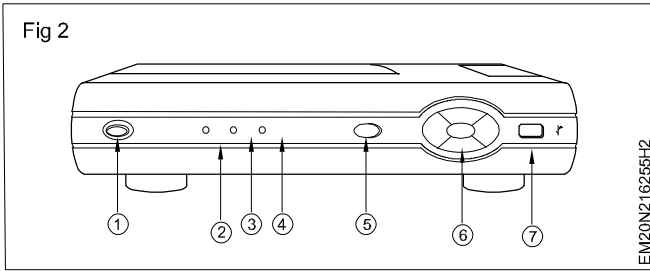

Table 2

Sl.No.	Name of the front panel control/indicator	Remarks
1		
2		
3		
4		
5		
6		
7		

**TASK 3: Connecting the set-top-box to the TV**

- Place the set-top box near the TV receiver at a convenient location.
- Use the 3RCA to 3RCA cable, connect the output of set-top box following the colour code, connect the video input, left channel and right channel of audio inputs on the TV as shown in Fig 1

- Change channels using the remote control of the set-top box and get the work checked by the instructor.
- Switch OFF both the set-top box and LCD/LED TV.

**If HDMI terminal is available on the set-top box, use HDMI cable and connect it to the HDMI-1 input of LCD/LED TV.**

- Connect the coaxial cable from dish antenna terminated with the F-connector to the set-top box and plug the mains cord to AC supply.
- Get the connections checked by the instructor.
- Switch ON the LCD/LED TV and Set-top box, use the remote control and select the AV input/HDMI-1 mode.
- Use the remote control of the set-top box and select the organize button, view the channel on the LCD/LED TV

